

**REF. 3.250**

**437-F Mueble TV**

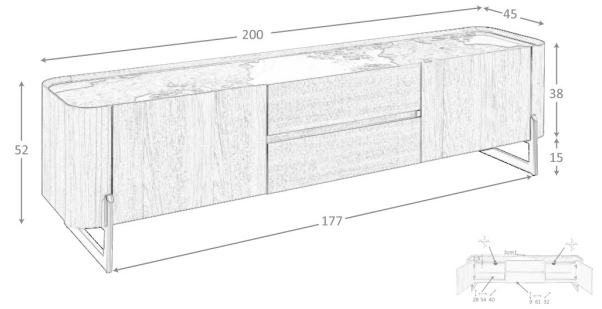

**MEDIDAS**

Medidas: 200 x 45 x 52 cm

Peso: 81 Kg

**EMBALAJE**

208 x 53 x 45 cm / 82 Kg

54 x 31 x 11 cm / 3 Kg

**VOLUMEN**

0,55 m3

**PRODUCTO**

Chapa Nogal

Tapa: Mármol Porcelánico Blanco M06 Brillo

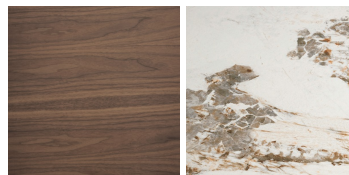

**PATAS**

Material Patas: Acero color Visión Metal

