

# Omne Editi

Vol. IV

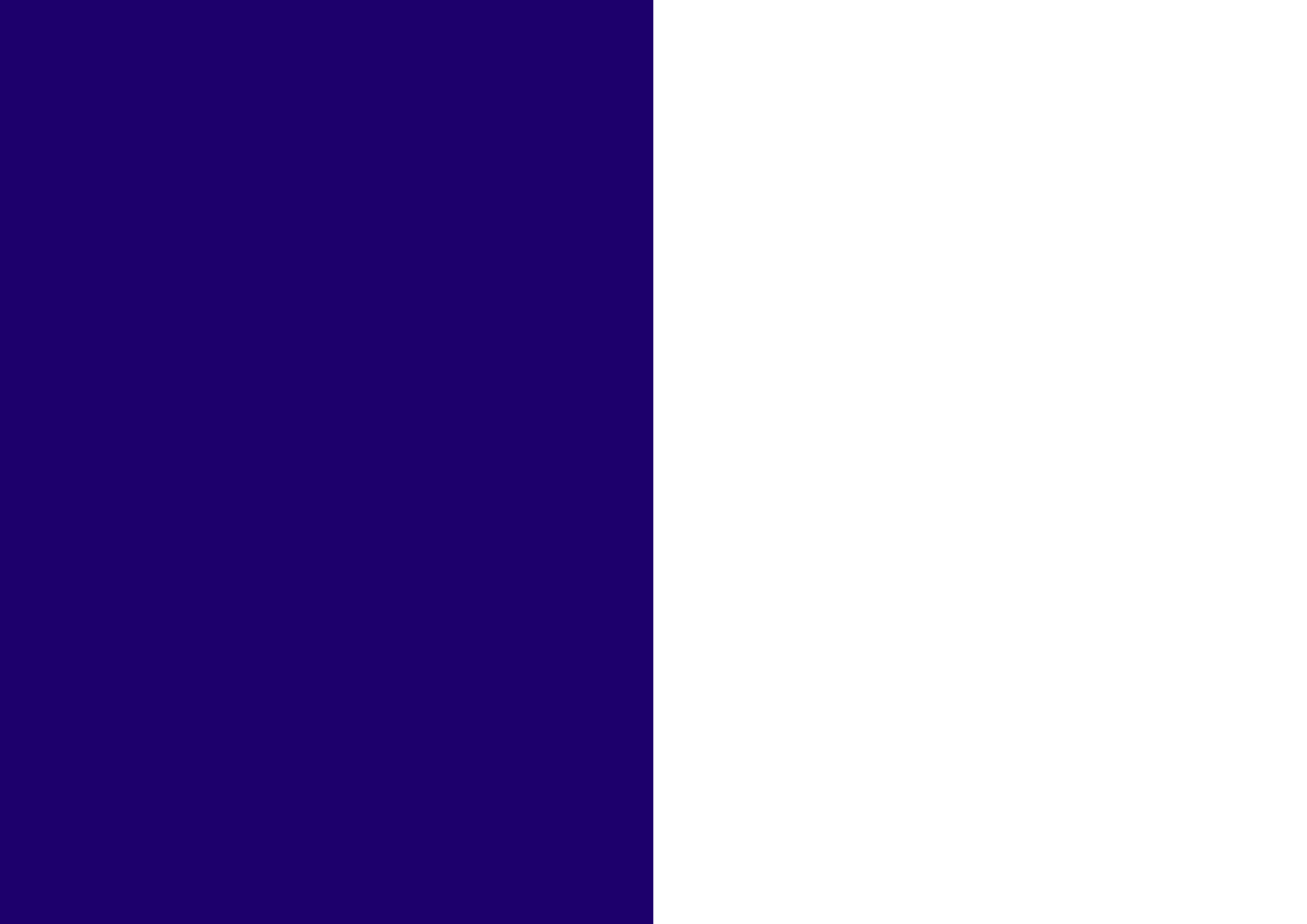

Concepto y Dirección de arte /  
Concept and Art Direction  
La Mamba Studio

Diseño editorial y concepto /  
Editorial design and concept  
La Mamba Studio

Fotografía / Photography  
Cualiti Photo Studio  
Eugeni Aguiló  
Pablo Santos

Renders  
La Mamba Studio

Copyright 2022 Omelette Editions  
Todos los derechos reservados. /All  
rights reserved.

Vol. IV



Savoye  
1

NEW



Majestic  
17



Alex Bistro  
99



Alex  
91



Terra Series  
105



Must  
41



Masala  
31



Nua  
49

NEW



Lasso  
121



Ox  
113



Alex Bistro Stool  
127

NEW



Downtown  
67



Mole  
61



Domus  
73



Terra Stool  
137



Domus Stool  
133



Fold  
81

NEW



Bison  
87



Mirror Collection  
149

# Savoye <sup>NEW</sup>

Designed by La Mamba

(ES)

El sofá Savoye ha sido diseñado para ofrecer una experiencia de gran confort. Sus proporciones son generosas y a la vez equilibradas. Los detalles marcan la diferencia de este espectacular sofá modular.

(EN)

The Savoye sofa has been designed to offer a very comfortable experience. Its proportions are generous and balanced. The details make the difference of this spectacular modular sofa.







↵ Composición sofá SAVOYE  
093+090+093 / SAVOYE sofa  
composition 093+090+093

↑ Detalle sofá SAVOYE /Detail SAVOYE  
sofa.



↑ Composición sofá  
SAVOYE 113+090+113  
/ SAVOYE sofa  
composition 113+090+113

→ Composición sofá SAVOYE  
113+090+090+P90 con lateral  
tapizado en otra tela /  
SAVOYE sofa composition  
113+090+090+P90  
with side upholstered in a  
different fabric





Composición sofá SAVOYE 113+090+113+  
TAB junto a mesa DOWNTOWN 120 y 85/  
Composition sofa SAVOYE 113+090+113+ TAB  
with table DOWNTOWN 120 and 85





→ Composición sofá SAVOYE  
MPI+090+090L+113L /  
SAVOYE sofa composition  
MPI+090+090L+113L



↖ Composición butaca SAVOYE 096 con mesa DOMUS 45 y HANG MIRROR / Composition SAVOYE 096 armchair with DOMUS 45 Coffe Table and HANG MIRROR

↑ Butaca SAVOYE 090 con mesa DOMUS 45 / Armchair SAVOYE 090 with table DOMUS 45.

Savoie modular

Savo 096. Armchair

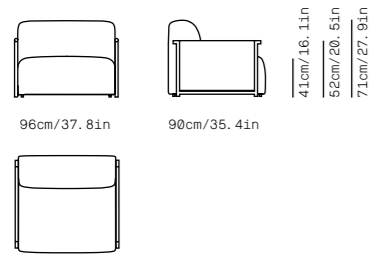

Savo 093. Lateral Element

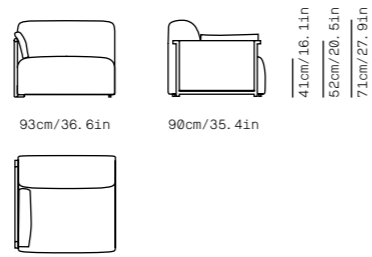

Savo 110. Lateral Element

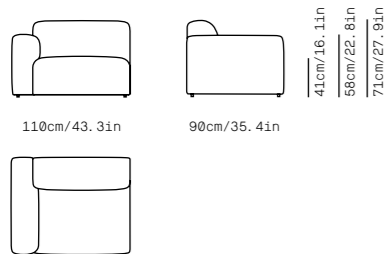

Savo 113. Lateral Element

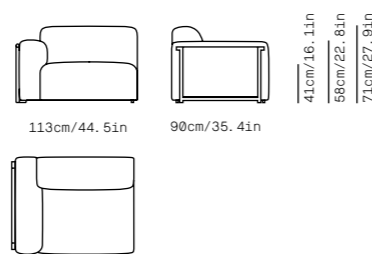

Savo 090. Central Element

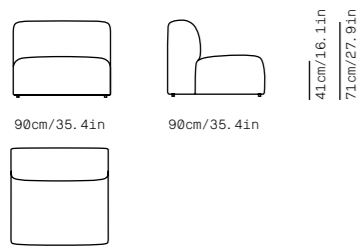

Savo MP1. Pouf Element

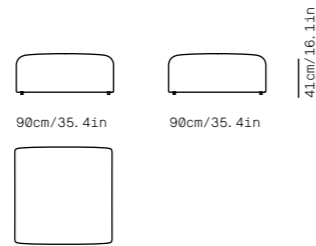

Savo RIN. Corner Element

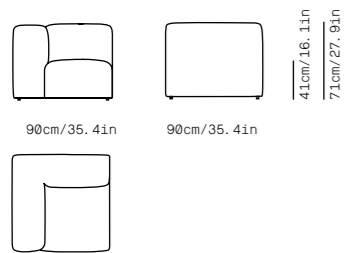

Savo P90. Auxiliar Pouf

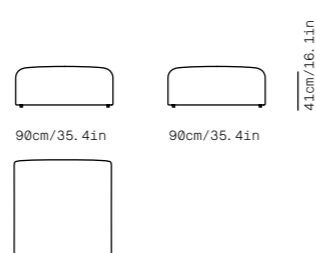

Savo 003. Lateral

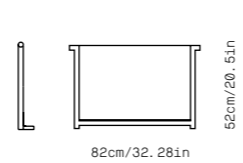

Savo TAB. Aux Table

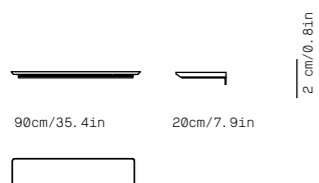

Savo 060. Aux cushion

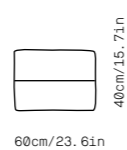

Savo 050. Aux cushion

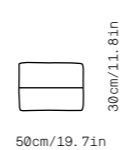

Savoie modular XL

Savo 093L. XL Lateral Element

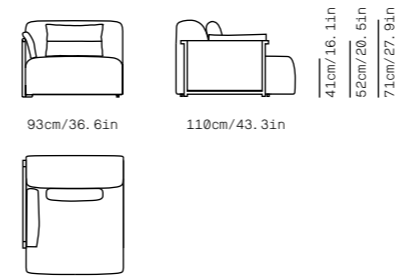

Savo 110L. XL Lateral Element

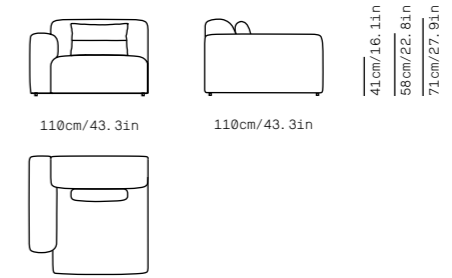

Savo 113L. XL Lateral Element

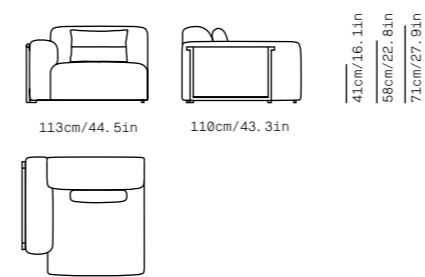

Savo 090L. XL Central Element

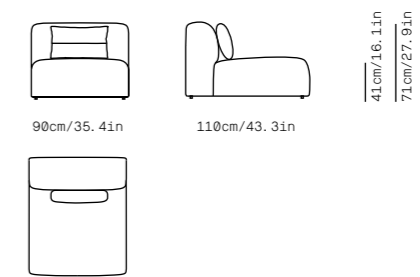

Example

Savo MP1+090+090+MP1+FOLD  
+090L+090L+090L+113L

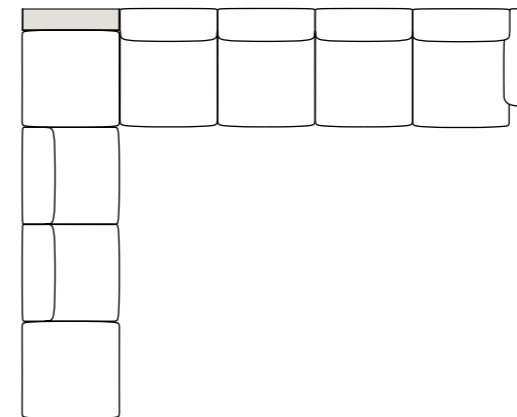

(ES) Estructura de madera de pino Flandes reforzada metalicamente. Asiento compuesto por espuma de poliuretano y viscoelástica libres de CFC, envuelto por edredón de microfibra. Cojín de respaldo y laterales compuestos por espuma de poliuretano de diferentes densidades libres de CFC. Totalmente desenfundable.

(EN) Flanders pine wood structure reinforced with metal. Seat cushion made of CFC-free polyurethane and viscoelastic foam, wrapped by hollow fibre duvet. Backrest and lateral cushion made CFC-free polyurethane foam of different densities. Totally removable.

# Majestic

Designed by La Mamba

(ES)

*Majestic*, aúna comodidad y ligereza a partir de un sofá de líneas rectas y sinuosas que invita a disfrutar de un momento de intimidad, descanso o conversación amistosa, en un entorno que destila sofisticación y encanto. Dos características que se integran de forma natural en cualquier hogar o espacio común.

Este sofá combina líneas elegantes, limpias y puras con el confort que proporciona una zona de confort y suavidad; cualidades que se transmiten al respaldo del sofá. Estéticamente, una de sus características más distintivas es una base visible formada por un sistema de doble pata que revela la ligereza y la fuerza de la estructura.

(EN)

*Majestic*, unites comfort and lightness based on a padded body that balances straight and sinuous lines, and invites you to enjoy a moment of intimacy, rest or a friendly conversation, in surroundings that ooze with sophistication and charm. Two features to make it blend in naturally in any home or communal space.

This sofa combines elegant, clean and pure lines with the comfort provided by a thick and soft sitting area, qualities that the back of the sofa also convey. Aesthetically, one of its most distinct features is a visible base made up of a double leg system that reveals the lightness and the strength of the structure.



↓ Detalle de la trasera del sofá MAJESTIC S4PXL / ↗ Sofá MAJESTIC S4PXL /  
Back detail of the MAJESTIC S4PXL sofa . MAJESTIC sofa S4PXL.





↙ Composición modular sofá  
MAJESTIC. Comp 02 / MAJESTIC  
modular sofa composition. Comp 02

↓ Detalle de butacas MAJESTIC B2 y  
mesas DOWNTOWN / Detail MAJESTIC B2  
armchair and DOWNTOWN coffee tables.





Sofas & Armchairs

OM Maje B2. Armchair

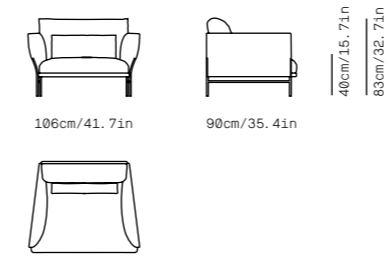

OM Maje PF90. Auxiliar Pouf

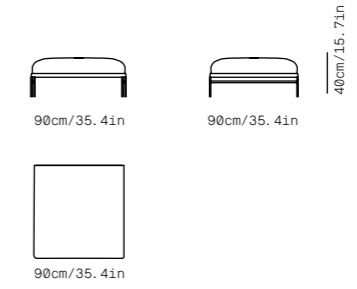

↓ Detalle de la trasera del sofá MAJESTIC S4PXL/  
Back detail of the MAJESTIC S4PXL sofa .



OM Maje S2P. Two seater sofa

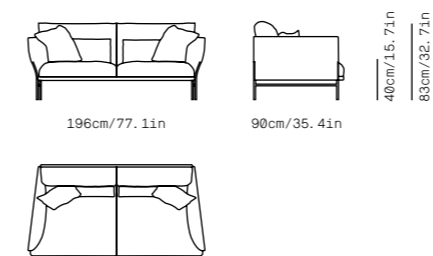

OM Maje S4P. Four seater sofa

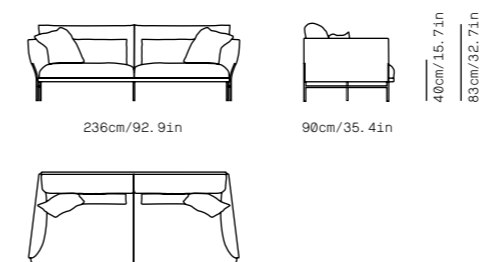

OM Maje S4PXL. XL Four seater sofa

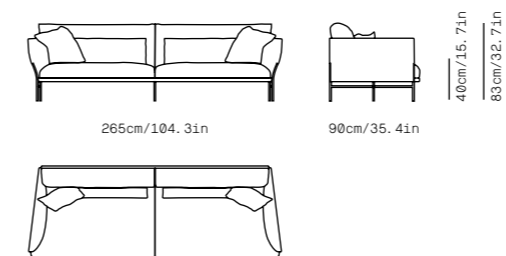

Modular elements

OM Maje MDB1. Lateral Element

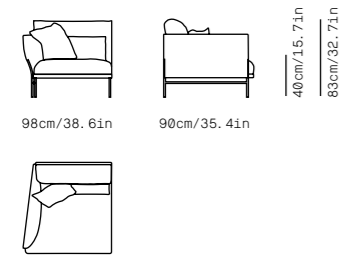

OM Maje MDB2. Lateral Element

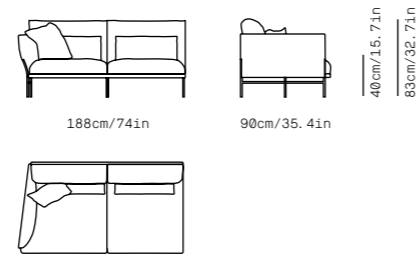

OM Maje MDB2XL. Lateral Element

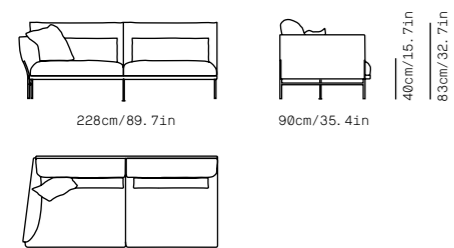

OM Maje MDB3. Lateral Element

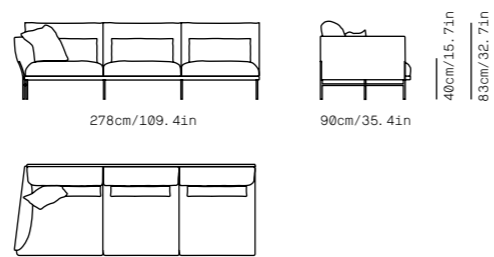

OM Maje MD1. Central Element

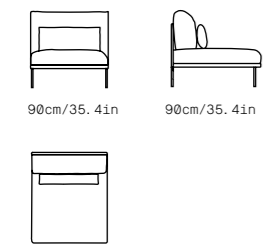

OM Maje MD2. Central Element

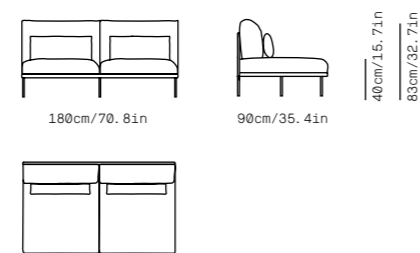

OM Maje MD2XL Central Element

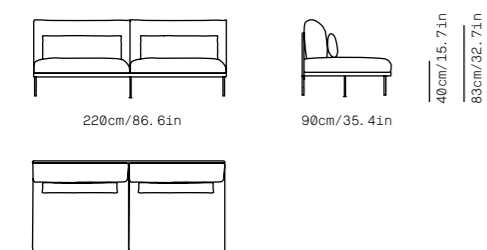

OM Maje MD3 Central Element

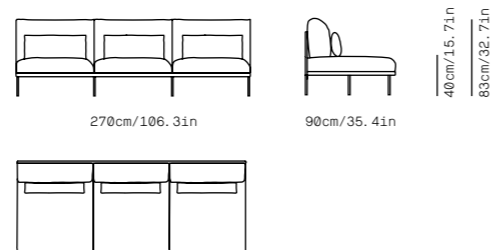

Modular elements

OM Maje MP1. Pouf Element

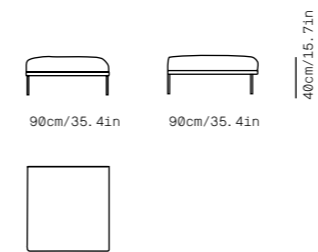

OM MajeCHL1. Chaise Longue

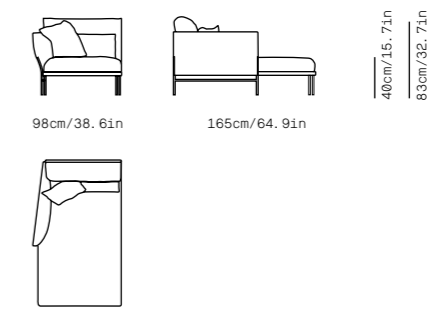

OM Maje RI. Corner Element

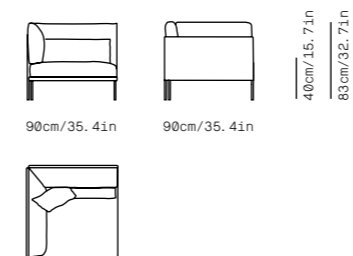

OM Maje 050. Aux Cushion

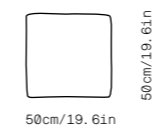

OM Maje 065. Aux Cushion

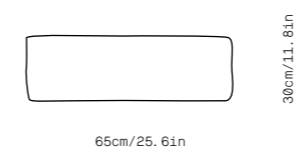

OM Maje 085. Aux Cushion

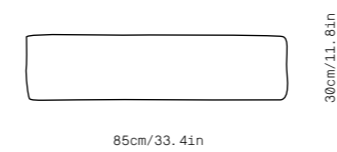



Composición modular sofá MAJESTIC /  
MAJESTIC modular sofa composition.

Compositions

Comp. 01 (MDB2+MDB1)

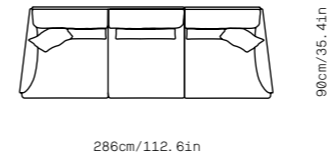

Comp. 02 (MDB2+CHL1)

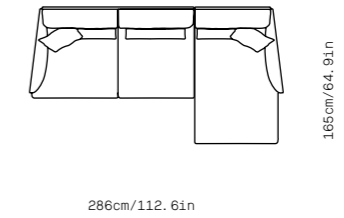

Comp. 03 (MDB2+RIN+MDB2)

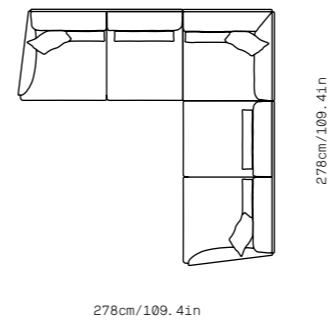

Comp. 04 (MDB3+RIN+MDB2)

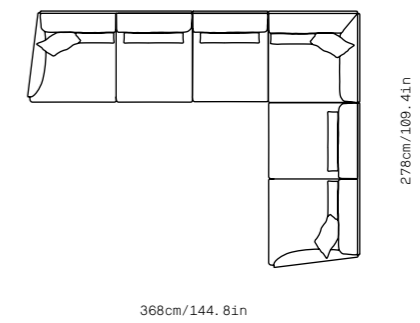

Comp. 05 (MDB3+RIN+MD2+P90)

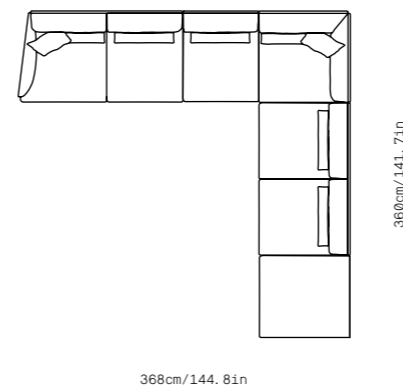

Comp. 06 (MDB2+RIN+P90+MDB2)

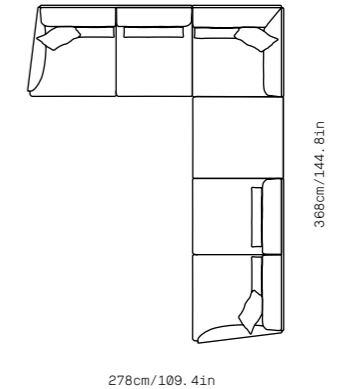

(ES)  
Estructura de madera de pino Flandes reforzada metálicamente. Pies metálicos termolacados. Suspensión de asiento mediante cinchas elásticas. Cojín de asiento compuesto por espuma de poliuretano libres de CFC, envuelto por edredón de microfibra. Cojín de respaldo compuesto por plumas de oca con alma de espuma de poliuretano libre de CFC, cojín riñonera compuesto por plumas de oca y microfibra. Totalmente desfundable.

(EN)  
Flanders pine wood structure reinforced with metal. Thermo-lacquered metal legs. Elastic webbing chair support. Seat cushion made of CFC-free polyurethane foam, wrapped by hollow microfibre. Backrest cushion made of goose feathers with a CFC-free polyurethane foam core, lumbar cushions made of goose feathers and microfibre. Totally removable.

# Masala

Designed by La Mamba

(ES)

Una cuidada y visible estructura en madera de nogal americano o madera de haya, dota a la colección Masala de una gran personalidad. El asiento, respaldo y apoyabrazos fabricados en espuma de poliuretano de diferentes densidades, cubiertos por un edredón de plumas de oca, ofrecen un gran confort. Un sofá riguroso y a la vez exquisito con tapizado desenfundable.

(EN)

An expressive, visible frame made of American walnut wood or beech wood, provides the Masala collection with great personality. The seat, backrest and armrests made of polyurethane foam with different densities, covered by a goose feather duvet, offer great comfort. A rigorous and at the same time exquisite sofa with removable upholstery.





↑ Detalle sofá MASALA con estructura de madera de haya /Detail MASALA sofa. Beech wood structure.

↗ Sofá MASALA S4PXL / MASALA sofa S4PXL





↑ ↗ Sofá MASALA S4PXL con estructura de nogal/  
MASALA S4PXL sofa with walnut structure





↑ Sofás MASALA S4PXL con estructura de madera de haya lacada en Azul, Granate y Negro /MASALA S4PXL sofas with beech wood structure lacquered in Blue, Maroon and Black.

↓ Butaca y sofá MASALA con estructura de haya lacada negra / MASALA armchair and sofa with black lacquered beech structure



**OM Masa B2. Armchair**

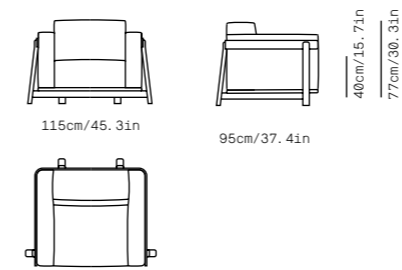

**OM Masa S2P. Two seater sofa**

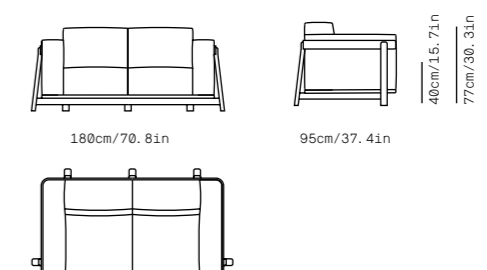

**OM Masa S3P. Three seater sofa**

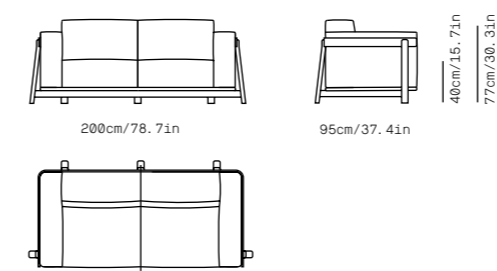

**OM Masa S4P. Four seater sofa**

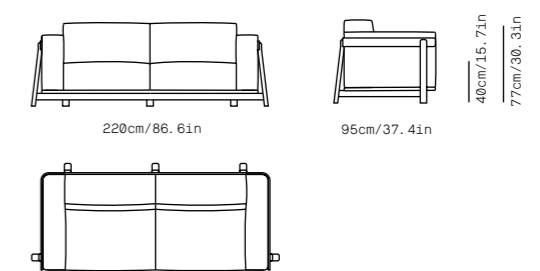

**OM Masa S4PXL. XL Four seater sofa**

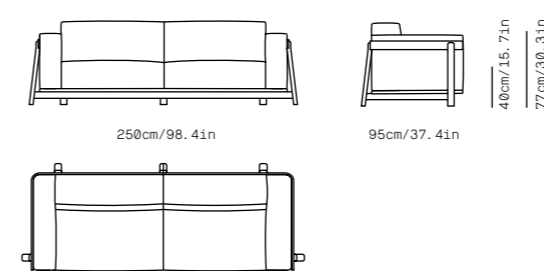

(ES)  
Estructura de madera maciza de haya o nogal, acabados disponibles: barnizado con acabado natural mate o lacado varios colores mate. Suspensión por cinchas elásticas. Cojines de asiento, respaldo y brazos compuestos por alma de espuma de poliuretano libre de CFC de varias densidades envueltas por edredón de plumas de oca y fibra hueca. Tapizado totalmente desenfundable.

(EN)  
Frame made of solid beech or walnut wood; available finishes: varnish with natural matt finish or varnished in several matt colours. Suspension by means of elastic belts. Seat cushions, back and arms made of a CFC-free polyurethane foam core, with different densities, wrapped in goose feather and hollow fibre duvets. Completely removable upholstery.



# Must

Designed by La Mamba

(ES)

El Sofá Must consiste de dos elementos importantes: por una parte, una estructura tubular ovalada que da soporte y, por otro, una carcasa de madera tapizada que funciona como contenedor de la cojinería que proporciona el confort a la hora de sentarse. Para La Mamba, "Must nace del concepto bañera que almacena en su interior un conjunto de cojines que aportan gran confort y espacio para relajarse, apoyados en una estructura que igual que la silla Terra, centra toda su personalidad en la fortaleza de su estructura. De esta manera y a través de líneas suaves y atractivas, rompemos con las formas tradicionales del sofá y conseguimos crear una silueta diferente a lo que encontramos en el mercado".

(EN)

Must Sofa consists of two important elements: on the one hand, a tubular oval structure that forms the base, and then an upholstered, wooden framework that acts as a container for the cushions, providing comfort when you are going to sit down. According to La Mamba, "Must has been created from the bath concept, accommodating a set of cushions that provide real comfort and space to relax, supported by a structure that, like the Terra chair, focuses all its personality in the strength of its structure. In this way and through its soft, attractive lines, we have broken away from the traditional lines of the sofa and have been able to create a different silhouette to that found on the market".



↓ Detalle de la trasera del sofá MUST/  
Detail of the back of the MUST sofa

↘ Sofá MUST 250 y mesa auxiliar DOMUS  
100 roble natural / MUST 250 sofa and  
DOMUS 100 natural oak side table



Composición de sofá MUST 250  
y mesas auxiliares DOMUS 100 y  
45 en roble natural/ Composition  
of sofa MUST 250 and side tables  
DOMUS 100 and 45 in natural oak



**Must 210. Three seater sofa**

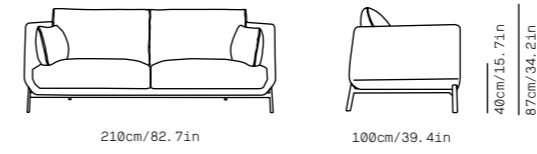

**Must 250. Four seater sofa**



↓ Detalle del sofá MUST/Detail of the MUST sofa



**OM Maje 050. Aux Cushion**

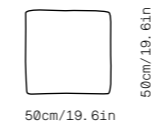

(ES)  
Estructura de madera de pino Flandes reforzada metálicamente. Pies metálicos termolacados. Suspensión de asiento mediante cinchas elásticas. Cojín de asiento compuesto por espuma de poliuretano libres de CFC, envuelto por edredón plumas de oca. Cojín de respaldo compuesto por plumas de oca y fibra. La estructura no es desfundable.

(EN)  
Flanders pine wood structure reinforced with metal. Thermo-lacquered metal legs. Elastic webbing chair support. Seat cushion made of CFC-free polyurethane foam, wrapped with goose feathers. Backrest cushion made of goose feathers and fibre. The structure is non-removable upholstery..

# Nua <sup>NEW</sup>

Designed by Altherr Désile Park

(ES)

Nua surge con el objetivo de ofrecer un producto de formas fáciles, un comodín para el hogar o para el hall de un hotel, un producto "Playful". Su estructura fabricada en madera de roble o fresno da carácter a esta interesante butaca. La colección se completa con el Ottoman para un confort total.

(EN)

Nua was created with the aim of offering a product with easy shapes, an easy chair for the home or for the hotel lobby, a "Playful" product. Its structure made of oak or ash wood gives character to this interesting armchair. The collection is completed by the Ottoman for total comfort.





↶ NUA acabado roble natural / NUA natural oak.

↑ NUA monocolor fresno lacado negro/ NUA monochrome black ash.





↑ NUA bicolor, roble natural y lacado negro/ NUA bicolour, natural oak and black lacquer.



↖ NUA bicolor , roble natural y lacado negro/  
NUA bicolour, natural oak and black lacquer.

↑ NUA monocolor fresno lacado negro con cojín respaldo/  
NUA monochrome black ash with back cushion.





↑ NUA monocolor fresno  
lacado negro/ NUA  
monochrome black ash.

↘ NUA acabado roble  
natural/ NUA natural oak.





↑ NUA monocolor fresno lacado  
rojo óxido/ NUA monochrome  
ash lacquered rust red

**Nua V1.**  
Sin cojín respaldo Without back cushion  
Asiento tapizado Upholstered seat

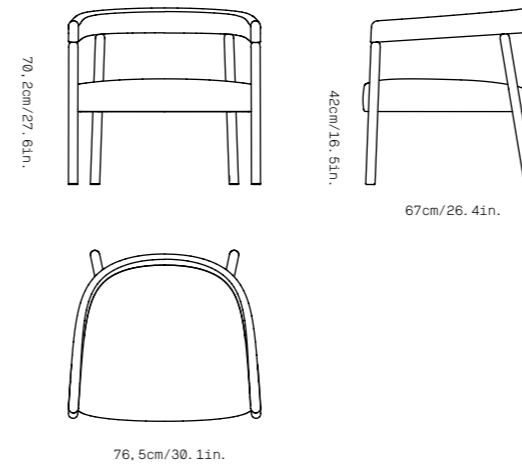

**Nua V2.**  
Con cojín respaldo With back cushion  
Asiento tapizado Upholstered seat

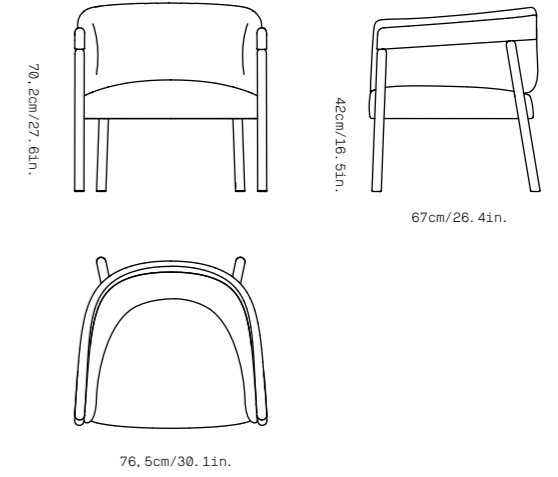

# Mole

Designed by La Mamba

(ES)

Las formas orgánicas y geométricas definen esta versátil colección de poufs que aportan carácter y personalidad a los espacios públicos y privados.

(EN)

Organic and geometrical shapes define this versatile collection of seats that provide public and private spaces with character and personality.



De izquierda a derecha:  
Pouf MOLE D58, D100, O100,  
D58,D100, O150 / From left to  
right: Pouf MOLE D58, D100,  
O100, D58,D100, O150



Pouf MOLE D100, Vertical Mirror y mesa auxiliar BISON 45 / Pouf MOLE D100, Vertical Mirror and side table BISON 45



**OM MoLeD58. Pouf**

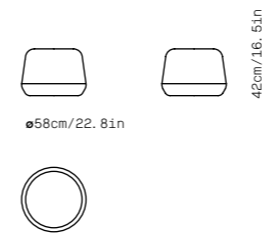

**OM MoLeD100. Pouf**

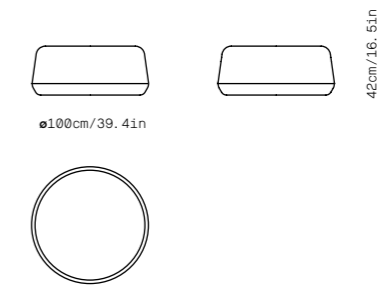

**OM MoLeOV100. Pouf**

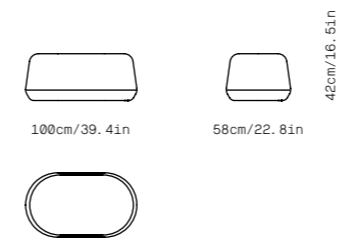

**OM MoLeOV150. Pouf**

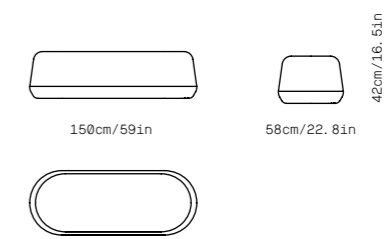

(ES)  
Monobloque de espuma de poliuretano de varias densidades libres de CFC con base de madera. Tapizado fijo.

(EN)  
Single block made of polyurethane with different densities, CFC-free with wooden base. Non-removable upholstery.

# Downtown

Designed by La Mamba

(ES)

La colección de mesas Downtown es una sinfonía de líneas simples y formas básicas que se contraponen en alturas y tamaños, para crear, como si de un collage se tratara, un juego de volúmenes en el espacio. Un conjunto de mesas auxiliares de centro cuyos detalles definen su diseño, con una línea dinámica que envuelve su estructura.

(EN)

The collection of Downtown tables is a symphony of simple lines and basic shapes that offset each other in height and size, to create a set of volumes in space, as if it were a collage. A group of side and coffee tables whose details define their design, with a dynamic line that surrounds their structure.



Composición de mesas de centro  
DOWNTOWN D120 y D85. Mesas  
auxiliares DOWNTOWN D50-30 y  
D50-40 / Composition of coffee tables  
DOWNTOWN D120 and D85. Side tables  
DOWNTOWN D50-30 and D50-40





↑ Composición de mesas de centro  
DOWNTOWN D120 y D85. / Composition of  
coffee tables DOWNTOWN D120 and D85.

OM Down D5030 Side table D50

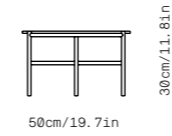

50cm/19.71in

30cm/11.81in

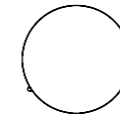

OM Down D5040 Side table D50

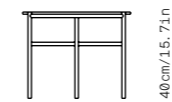

50cm/19.71in

40cm/15.71in

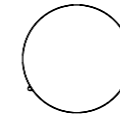

OM Down D5050 Side table D50

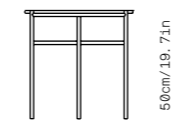

50cm/19.71in

50cm/19.71in

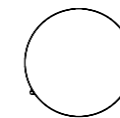

OM Down D85 Coffee table D85

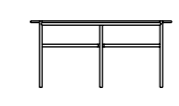

85cm/33.51in

40cm/15.71in

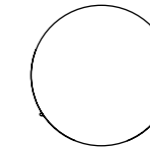

OM Down D120 Coffee table D120

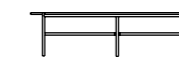

120cm/47.21in

30cm/11.81in

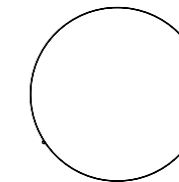

(ES)  
Pies metálicos macizos termolacados.  
Sobre de material porcelánico en  
diferentes colores así como de  
madera contrachapada, disponible en  
diferentes acabados.

(EN)  
Solid thermo-lacquered metal legs.  
Porcelain top in different colours  
as well as plywood, available in  
different finishes.



# Domus

Designed by Isaac Piñeiro

(ES)

La colección Domus parte de una afirmación “Es una colección que me encantaría producirla yo mismo en un taller de madera por su sencillez y forma robusta” Un ejercicio de simplicidad, sobriedad y carácter, con dos detalles que lo definen, del corte de la pata y su encuentro con la parte del sobre. La colección de mesas auxiliares y de centro se completa con unos taburetes de dos alturas.

(EN)

The Domus collection is based on a statement; “It is a collection that I would love to produce myself in a carpenter’s workshop, owing to its simplicity and robust form.” An exercise in simplicity, sobriety and character, defined by two details, the cut of the leg and its meeting with the top. The collection of occasional and centre tables is complemented with stools in two heights.



De izquierda a derecha: DOMUS  
71, 100, 45 y 120 / From left to  
right: DOMUS 71, 100, 45 y 120





↵ Composición de mesas de centro DOMUS 100, 45 y 120 junto a mesa auxiliar DOMUS 71/ Composition of coffee tables DOMUS 100, 45 and 120 together with side table DOMUS 71

↑ Composición de mesas DOMUS/ Composition of DOMUS tables

↓ Detalle mesa DOMUS 120 /  
Detail of DOMUS 120 table



**Domus 45 Side table**

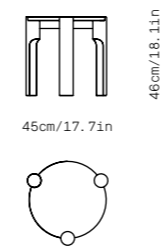

**Domus 71 Coffee table**

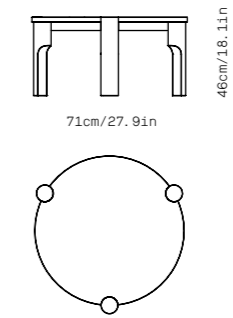

**Domus 100 Coffee table**

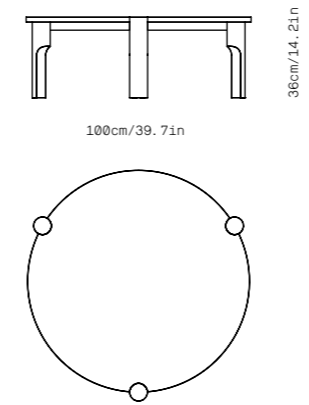

**Domus 120 Coffee table**

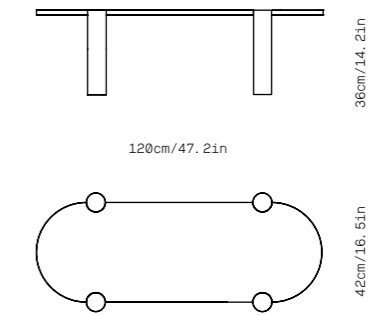

(ES)  
Mesa realizada íntegramente en  
madera de roble macizo o fresno.  
Acabado natural, negro y humo

(EN)  
Table made in solid oak or ash wood.  
Natural, black and smoke finish

# Fold NEW

Designed by La Mamba

(ES)

Diseñada como una opción de almacenamiento versátil, la mesa Fold está abierta a diversas interpretaciones, una mesa auxiliar independiente o una mesa para acompañar al sofá Savoye. Encarnando la pureza en su grado más elegante, la estricta geometría de esta mesa nos recuerda a los principios estéticos de la Bauhaus.

(EN)

Designed as a versatile storage option, the Fold table is open to a variety of interpretations, a freestanding side table or a table to accompany the Savoye sofa. Embodying purity at its most elegant, the strict geometry of this table is reminiscent of Bauhaus aesthetic principles.





↖ Composición FOLD en acabado negro con el sofá SAVOYE/ FOLD composition in black finish with SAVOYE sofa.

↑ Detalle composición FOLD en acabado blanco con el sofá SAVOYE/ Detail of FOLD composition in white finish with SAVOYE sofa.



↑ Detalle mesa FOLD en acabado rojo flúor/ FOLD table detail in fluorescent red finish.

**Fold. Side Table**

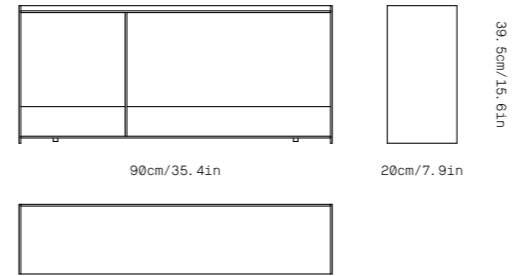

(ES)  
Mesa auxiliar disponible en acabado negro, blanco y rojo flúor.

(EN)  
Side table available in black, white and fluorescent red finish.

# Bison

Designed by La Mamba

(ES)

Bison es una colección de mesas auxiliares disponibles en dos tamaños con un alto dinamismo visual gracias a la posibilidad de combinar acabados, rompiendo la monotonía de los espacios. Ideal para entornos residenciales y colectividades.

La colección de mesas bajas auxiliares Bison destacan por su trazado simple y único, que conferirá a cualquier espacio la superficie ideal para dejar nuestros objetos favoritos o nuestra taza de café.

Las mesas cuentan con una estructura de tres patas y un sobre de aspecto fino y delgado. Cabe destacar que las mesas BISON están realizadas en madera maciza de roble o fresno en tres acabados distintos; roble natural mate, fresno lacado a poro abierto negro mate y humo glaseado mate que reflejan esta nueva imagen de madurez y sobriedad de Omelette Editions.

(EN)

Bison is a collection of side tables available in two sizes. Visually dynamic thanks to the possibility of combining finishes, it breaks with the monotony of the spaces. They are ideal for residential and contract environments.

Bison side tables stand out for their simple, unique outline, which will lend any space the ideal surface to leave our favourite objects or coffee cup.

The tables have a three-legged structure and a slim, elegant table top. It should be noted that the BISON tables are made from solid oak or ash in three different finishes; matte natural oak, black matte lacquered open-pore ash, and matte smoke glaze that reflect Omelette Editions new image of maturity and sobriety.





**Bison 45 Side table**

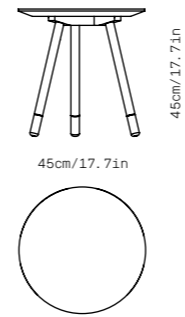

(ES)  
Mesa realizada íntegramente en  
madera de roble macizo o fresno.  
Acabado natural, negro y humo

**Bison 71 Side table / Coffee Table**

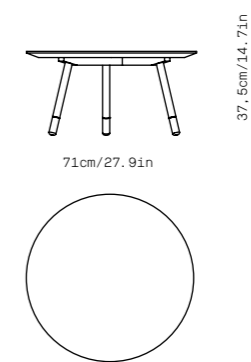

(EN)  
Table made in solid oak or ash wood.  
Natural, black and smoke finish



# Alex

Designed by Isaac Piñeiro

(ES)

La idea de buscar una silla de simplicidad extrema con elementos estándar y alcanzar un grado de expresividad suficiente para dotarla de identidad fue el comienzo de este proyecto. Se trata de una silla apilable informal que tiene una variedad de propósitos que van desde colocarla en áreas de reunión o espacios abiertos de una oficina a restaurantes u hogares.

El nombre viene de Alexander Calder, punto de inspiración por sus esculturas y el punto de equilibrio que conseguía a través de las formas, las líneas el color y los diferentes materiales.

(EN)

This project began with the idea of seeking an extremely simple chair with standard elements and achieving a sufficient level of expressiveness to give it its own identity. This is an informal, stackable chair with a variety of purposes, which can be placed anywhere from meeting areas or open spaces in an office to restaurants or homes.

The name comes from Alexander Calder, a source of inspiration owing to his sculptures and the balancing point he achieved through shapes, lines, colours and different materials.





Alex

↶ Silla ALEX V2 con reposabrazos / ALEX V2 with armrest chair.

↑ Silla ALEX V2 con reposabrazos apilable / ALEX V2 with armrest stackable chair.

Familia de sillas ALEX / ALEX  
family of chairs





↑ Silla ALEX V1 acabado Roble Humo/  
ALEX V1 Chair in Smoke Oak finish

Alex V1 Sin tapizar Unupholstered

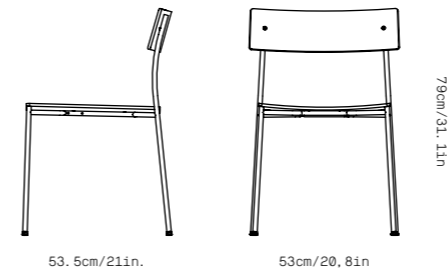

53.5cm/21in.

53cm/20, 8in

79cm/31.1in



Alex VT1 Tapizada Upholstered

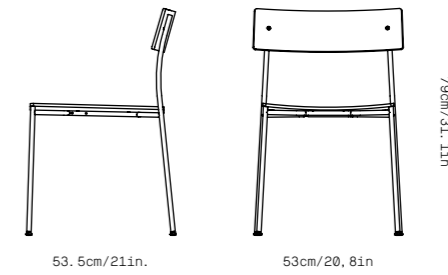

53.5cm/21in.

53cm/20, 8in

79cm/31.1in



Alex V2 Sin tapizar Unupholstered

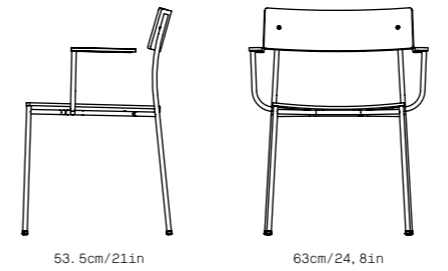

53.5cm/21in

63cm/24, 8in

79cm/31.1in



Alex VT2 Tapizada Upholstered

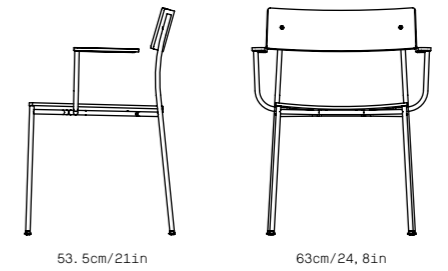

53.5cm/21in

63cm/24, 8in

79cm/31.1in



(ES)  
Estructura de metal lacada. Asiento y respaldo en tablero curvado acabado roble. Acabado natural, negro y humo. Opción con asiento tapizado

(EN)  
Lacquered metal frame. Seat and backrest in curved oak-finish plywood. Natural, black and smoke finish. Option with upholstered seat

# Alex Bistro

Designed by Isaac Piñeiro

(ES)

Alex Bistro es la hermana menor de Alex. Comparten la simplicidad extrema y una expresividad que la dota de identidad. Alex Bistro es una silla apilable pensada para espacios más compactos, ya sean contract o domésticos. Actualmente está disponible en madera curvada en tres acabados, roble natural, roble teñido negro y roble teñido humo, asiento tapizado en tela con varios acabados.

(EN)

Alex Bistro is the younger sister of Alex. They share an extreme simplicity and an expressiveness that gives it an identity. Alex Bistro is a stackable chair designed for more compact spaces, whether it be work or domestic. It is currently available in curved wood in three finishes; natural oak, black-stained oak and smoke-stained oak. The seat is upholstered in fabric with various finishes.





↙ Silla ALEX BISTRO y mesa LASSO 200/  
ALEX BISTRO chair and LASSO 200 table

↓ Silla ALEX BISTRO VT1/  
ALEX BISTRO VT1 chair





↑ Silla ALEX BISTRO V1 apilable/ ALEX BISTRO V1 stackable chair

Alex Bistro V1 Sin tapizar Unupholstered

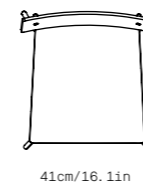
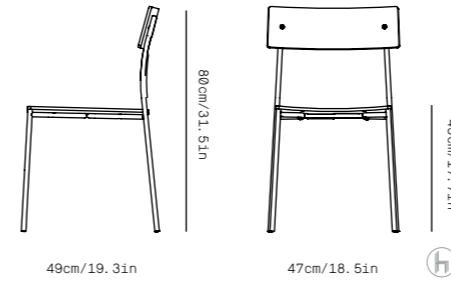

(ES)  
Estructura de metal lacada. Asiento y respaldo en tablero curvado acabado roble. Acabado natural, negro y humo. Opción con asiento tapizado

Alex Bistro VT1 Tapizada Upholstered

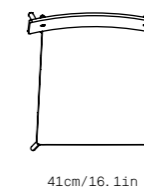
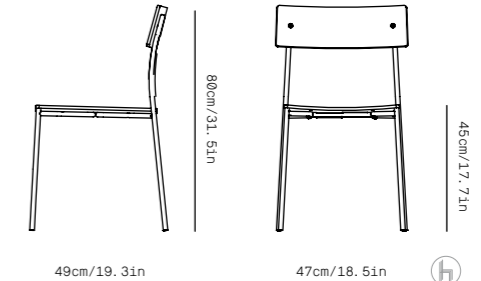

(EN)  
Lacquered metal frame. Seat and backrest in curved oak-finish plywood. Natural, black and smoke finish. Option with upholstered seat



# Terra Series

Designed by Isaac Piñeiro

(ES)

TERRA es una colección sencilla, pero con mucho carácter, cuyos detalles definen su aspecto general y potencian el trabajo artesano de la ebanistería y el metal, combinado con el proceso industrial de la madera curvada. La rectitud de la estructura contrasta con el suave curvado del conjunto que forman asiento y respaldo. Isaac Piñeiro define el asiento como "una silueta de líneas suaves que se une a una estructura de roble o metal". El encuentro entre asiento y estructura desempeña un papel de suma relevancia, ya que da la impresión de que el asiento se soporta prácticamente sin apoyos sobre la estructura.

La colección ha sido concebida tanto para espacios domésticos como para un contract que busque calidad formal y material. Isaac Piñeiro, para aportar más opciones, la ha vestido con tejidos que acompañan los distintos acabados de la madera.

Ahora, la familia TERRA crece y la colección incorpora un nuevo pie, en este caso giratorio.

(EN)

Terra is a simple collection yet full of character, whose details define its overall look and highlight the craftsmanship of the wood- and metalwork, in combination with the industrial process of wood bending. The straightness of its structure contrasts with the soft curves of the seat and backrest. Isaac Piñeiro defines the seat as "a silhouette of soft lines joined to a structure of oak or metal". The meeting point between the seat and structure plays a very important role, as it gives the impression that the seat is sustained by hardly any supports on the structure.

The collection has been designed both for domestic interiors and contract spaces that are looking for quality in form and materials. To provide more options, Isaac Piñeiro has dressed it with fabrics that accompany the different wood finishes.

Now, The TERRA family has grown. The collection incorporates a new leg, in this case a swivel base.





↵ Silla TERRA wood VT1 tapizada acabado roble natural/ TERRA wood VT1 upholstered in natural oak

↑ Silla TERRA wood en sus dos versiones tapizada y sin tapizar en roble / TERRA wood in its two versions upholstered and without, in oak.

De izquierda a derecha:  
TERRA Stool 65, TERRA Wood,  
TERRA Swevel y TERRA Metal  
/ From left to right: TERRA  
Stool 65, TERRA Wood, TERRA  
Swevel and TERRA Metal





**Terra Wood V1 Sin tapizar Unupholstered**

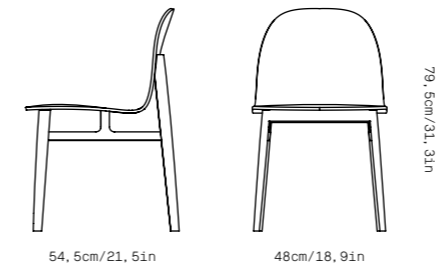

**Terra Wood VT1 Tapizada Upholstered**

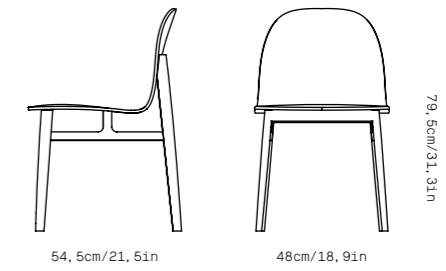

**Terra Metal V1 Sin tapizar Unupholstered**

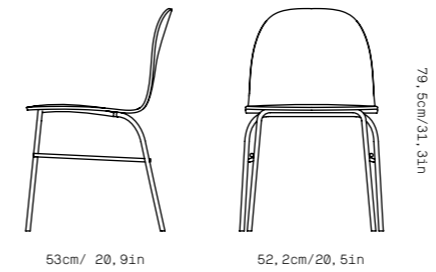

**Terra Metal VT1 Tapizada Upholstered**

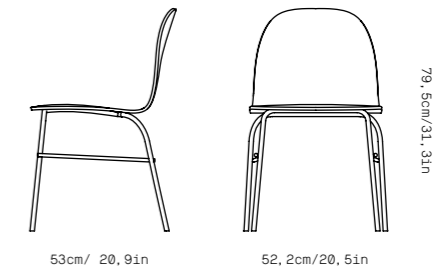

**Terra Swivel V1 Sin tapizar Unupholstered**

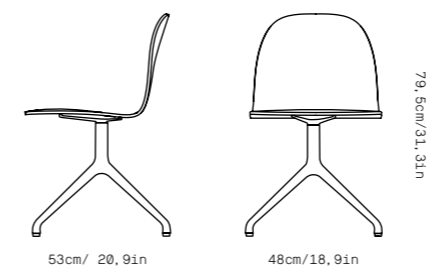

**Terra Swivel VT1 Tapizada Upholstered**

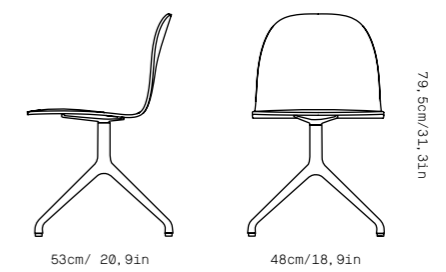

(ES)  
Estructura de metal lacada o  
madera maciza. Asiento y respaldo  
en tablero curvado acabado roble.  
Acabado natural, negro y humo.  
Opción con tapizado interior

(EN)  
Frame in lacquered metal or solid  
wood. Seat and backrest in curved  
oak-finish board. Natural, black and  
smoke finish. Option with interior  
upholstery

# Ox

Designed by Francesc Rifé

(ES)

Como si se tratara de un árbol vigoroso y estable, el tronco y las raíces marcan la vida y expresividad de la nueva colección de mesas de Francesc Rifé para Omelette Editions. La estructura lineal de la base se articula bajo un sistema de cruces, simétrico y preciso, que dialoga siempre con un sobre de forma curva. Disponible en una gran variedad de colores y tamaños, el resultado es una composición equilibrada y estrictamente funcional.

(EN)

As though it were a vigorous and stable tree, the trunk and roots mark the life and expressiveness of the new collection of tables by Francesc Rifé for Omelette Editions. The linear structure of the base is articulated under a system of crosses, symmetrical and precise, that hold a continuous dialogue with a curved top. Available in a wide variety of colours and sizes, the result is a balanced and strictly functional composition.





↵ Mesa OX C120 con sobre acabado roble lacado negro / OX C120 table in black lacquered oak finish top



↑ Mesa OX C120 junto a la silla ALEX y la lámpara BOLD / OX C120 table together with ALEX chair and BOLD lamp.



↑ Mesa OX C90 con sobre acabado roble natural / OX C90 table with natural oak finish top

↗ Composición Mesa OX C80 y silla ALEX BISTRO / Composition OX C80 table and ALEX BISTRO chair





OX-C90

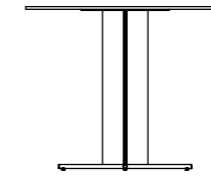
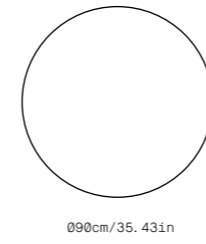

74.5cm/29.331in

MDF TOP

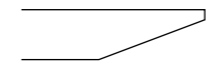

2.5 cm/0.981in

(ES)  
Estructura de metal lacada.  
Sobre en MDF chapado roble. Acabado  
roble natural, roble humo o roble negro

OX-C120

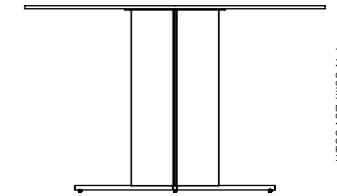
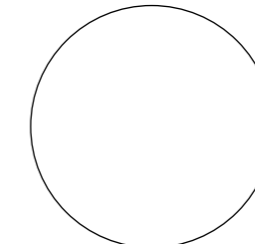

74.5cm/29.331in

(EN)  
Lacquered metal structure.  
Top in oak veneered MDF. Natural  
oak, smoke oak or black oak finish.

↑ Mesa OX C120 junto a la silla ALEX, la lámpara BOLD y CIRCULAR MIRROR/ OX C120 table together with ALEX chair, BOLD lamp and CIRCULAR MIRROR.



# Lasso

Designed by Iratzoki Lizaso

(ES)

El nombre Lasso viene del modo de juntar los pies con una especie de travesaño continuo que los atrapa como si fuera un lazo. El sutil gesto de curvado que tienen a la altura del aro es uno de los detalles que dan personalidad a esta pieza, inspirada en anteriores diseños de la editora.

"Hemos tratado de ser coherentes con la historia de Omelette Editions en el uso de material y tono general de la pieza" -explican desde Iratzoki-Lizaso- "Así, hemos optado por una base metálica, similar a la de sus espejos, y una superficie de madera con un perfil de media caña. Esta mesa estará disponible en tres acabados, roble en natural, negro y humo, por debajo del sobre será en color negro al igual que su estructura. Detalles que hablan el mismo idioma que los productos precedentes de Omelette Editions y que dan un mayor significado a la colección".

(EN)

The name Lasso comes from the way the legs are joined together with a sort of continuous crosspiece that traps them like a lasso. The subtle curve in the legs at the height of this loop is one of the details that imbue the piece with personality, inspired by previous Omelette Editions designs.

"We have tried to be consistent with Omelette Editions's history through the use of materials and the general tone of the piece" -as they explained from Iratzoki-Lizaso- "So we opted for a metal base, similar to the mirror base and a wooden surface with a half round profile. This table will be available in three finishes: natural oak, black and smoke, and the underside of the tabletop will be black like its structure. These details speak the same language as Omelette Editions's former products and give greater meaning to the collection".





∟ Conjunto mesa LASSO 200 con sillas TERRA / Table set LASSO 200 with TERRA chairs.

↑ Detalle mesa LASSO 200 roble natural y silla TERRA Metal roble natural tapizada / Detail of LASSO 200 oak table natural oak and TERRA chair natural oak metal upholstery

↙ Conjunto mesa LASSO 100 con sillas  
TERRA metal / Table set LASSO 100 with  
TERRA metal chairs.



Lasso 100

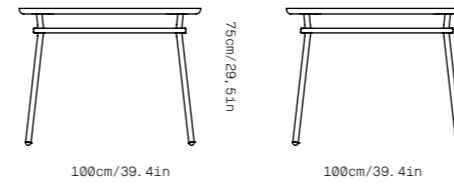

Lasso 200

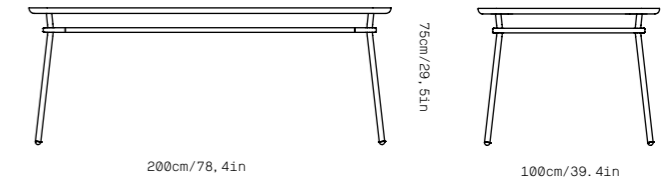

MDF TOP

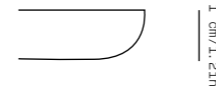

(ES)  
Estructura de metal lacada.  
Sobre en MDF chapado roble. Acabado  
roble natural, roble humo o roble negro

(EN)  
Lacquered metal structure.  
Top in oak veneered MDF. Natural  
oak, smoke oak or black oak finish.

# Alex Bistro <sup>NEW</sup> Stool

Designed by Isaac Piñeiro

(ES)

Alex Bistro Taburete es la última novedad de la colección Alex. Un taburete apilable pensado para espacios más compactos, ya sean contract o domésticos. Comparte como el resto de la colección una simplicidad extrema y una expresividad que la dota de identidad. Actualmente está disponible en madera curvada en tres acabados, roble natural, roble teñido negro y roble teñido humo, asiento tapizado en tela con varios acabados.

(EN)

Alex Bistro Stool is the latest addition to the Alex collection. A stackable stool designed for more compact spaces, whether it be work or domestic. Like the rest of the collection, it shares an extreme simplicity and an expressiveness that gives it an identity. It is currently available in curved wood in three finishes, natural oak, black-stained oak and smoke-stained oak, seat upholstered in fabric in several finishes.





Alex Bistro Stool

↖ ALEX BISTRO STOOL roble natural y ALEX BISTRO STOOL respaldo roble negro y asiento tapizado/  
 ALEX BISTRO STOOL natural oak and ALEX BISTRO STOOL black oak back and upholstered seat

↑ ALEX BISTRO STOOL roble negro/ ALEX BISTRO STOOL black oak

↓ ALEX BISTRO STOOL  
 roble natural/ ALEX BISTRO  
 STOOL natural oak



**Alex Stool V1**  
 Sin tapizar Unupholstered

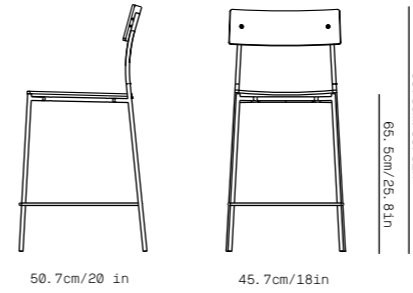

(ES)  
 Estructura de metal lacado negro.  
 Respaldo en tablero curvado en  
 roble. Disponible en acabado  
 natural, negro y humo. Asiento en  
 roble con posibilidad de tapizado.

**Alex Stool VT1**  
 Tapizada Upholstered

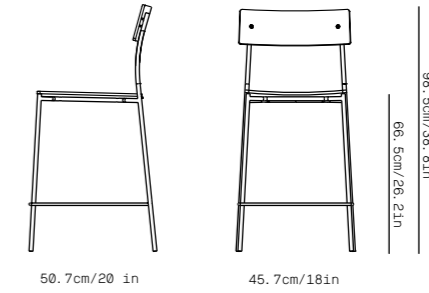

(EN)  
 Black lacquered metal frame.  
 Backrest in curved oak board.  
 Available in natural, black and  
 smoke finish. Oak seat with the  
 possibility of upholstery.

# Domus Stool

Designed by Isaac Piñeiro

(ES)

La colección Domus parte de una afirmación “Es una colección que me encantaría producirla yo mismo en un taller de madera por su sencillez y forma robusta” Un ejercicio de simplicidad, sobriedad y carácter, con dos detalles que lo definen, del corte de la pata y su encuentro con la parte del sobre. La colección de mesas auxiliares y de centro se completa con unos taburetes de dos alturas.

(EN)

The Domus collection is based on a statement; “It is a collection that I would love to produce myself in a carpenter’s workshop, owing to its simplicity and robust form.” An exercise in simplicity, sobriety and character, defined by two details, the cut of the leg and its meeting with the top. The collection of occasional and centre tables is complemented with stools in two heights.





↑ Taburete DOMUS S46 y Mesa OX /  
DOMUS S46 stool and OX table.

Domus S65

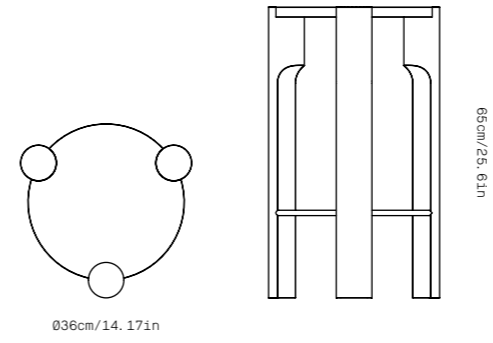

(ES)  
Taburete realizado íntegramente en  
madera de roble macizo o fresno con  
refuerzo metálico  
Acabado natural, negro y humo

Domus S46

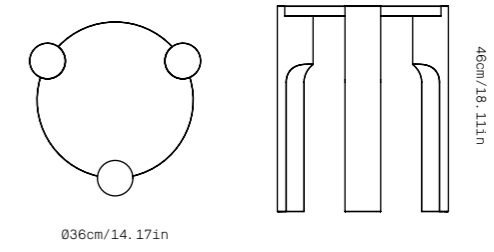

(EN)  
Stool made entirely of solid oak or  
ash wood with metal reinforcement.  
Natural, black and smoke finish



# Terra Stool

Designed by Isaac Piñeiro

(ES)

TERRA es una colección sencilla, pero con mucho carácter, cuyos detalles definen su aspecto general y potencian el trabajo artesano de la ebanistería y el metal, combinado con el proceso industrial de la madera curvada. La rectitud de la estructura contrasta con el suave curvado del conjunto que forman asiento y respaldo. Isaac Piñeiro define el asiento como "una silueta de líneas suaves que se une a una estructura de roble o metal". El encuentro entre asiento y estructura desempeña un papel de suma relevancia, ya que da la impresión de que el asiento se soporta prácticamente sin apoyos sobre la estructura.

La colección ha sido concebida tanto para espacios domésticos como para un contract que busque calidad formal y material. Isaac Piñeiro, para aportar más opciones, la ha vestido con tejidos que acompañan los distintos acabados de la madera.

(EN)

Terra is a simple collection yet full of character, whose details define its overall look and highlight the craftsmanship of the wood- and metalwork, in combination with the industrial process of wood bending. The straightness of its structure contrasts with the soft curves of the seat and backrest. Isaac Piñeiro defines the seat as "a silhouette of soft lines joined to a structure of oak or metal". The meeting point between the seat and structure plays a very important role, as it gives the impression that the seat is sustained by hardly any supports on the structure.

The collection has been designed both for domestic interiors and contract spaces that are looking for quality in form and materials. To provide more options, Isaac Piñeiro has dressed it with fabrics that accompany the different wood finishes.





↑ Taburete TERRA S75 / TERRA S75 stool

**Terra Metal S65 V1**  
Sin tapizar Unupholstered

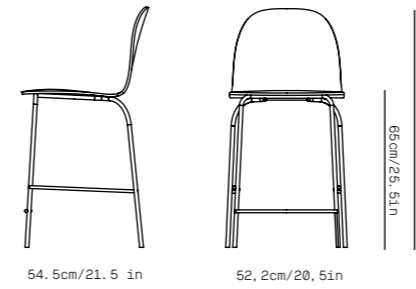

**Terra Metal S65 VT1**  
Tapizada Upholstered

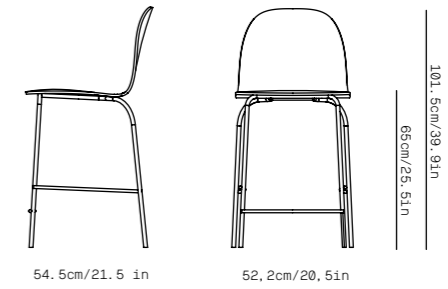

**Terra Metal S75 V1**  
Sin tapizar Unupholstered

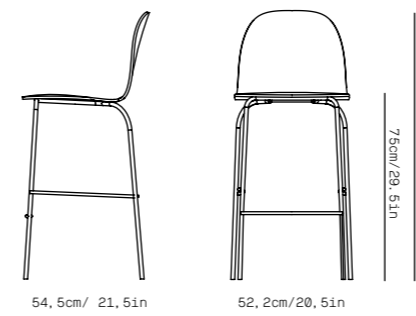

**Terra Metal S75 VT1**  
Tapizada Upholstered

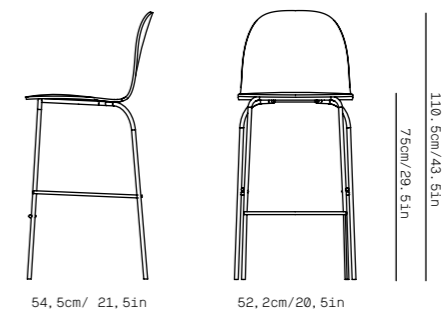

(ES)  
Estructura de metal lacada. Asiento y respaldo en tablero curvado acabado roble. Acabado natural, negro y humo. Opción con tapizado interior

(EN)  
Frame in lacquered metal. Seat and backrest in curved oak-finish board. Natural, black and smoke finish. Option with interior upholstery

# Mirror Collection

Designed by La Mamba

(ES)

Mirror collection es una colección de espejos de pared con diferentes formas geométricas círculo y rectángulo. Nace de la interpretación de mover o desplazar los objetos sin necesidad de permanencia en un espacio, pudiendo estar un día en el salón y otro en la habitación principal.

La colección cuenta con tres modelos de espejos, circular con pies, rectangular vertical con pies y circular para colgar en pared. Diseñados para apoyar y fijarlos de pie contra la pared, de líneas simples y contemporáneas que juegan con una estructura metálica finalizada en dos pies de corcho que evitan el desplazamiento.

(EN)

Mirror collection is a collection of wall mirrors in different geometric shapes, both circular and rectangular. It comes from an understanding that objects can be moved or rearranged without them needing to stay permanently in one space, so that one day they might be in the sitting room and another in the main bedroom.

The collection has three models of mirrors, a circular mirror with legs, a vertical, rectangular mirror with legs and a circular mirror to hang on the wall. Designed to lean against or be fixed to the wall, their simple, contemporary lines play with a metal structure finished with two cork feet to prevent slipping.



↓ Hang MIRROR negro  
/ Black hang MIRROR.

↘ Vertical MIRROR negro, silla TERRA  
wood en roble negro / Black vertical  
MIRROR, TERRA wood black oak.





↑ Circular MIRROR negro / Black circular MIRROR.

Vertical Mirror

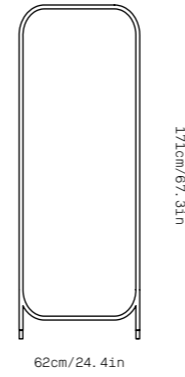

Hang Mirror

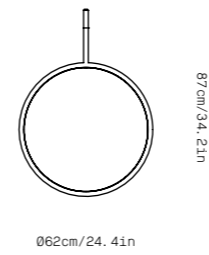

(ES)  
Estructura metálica con pies de corcho. Acabado blanco o negro

Circular Mirror

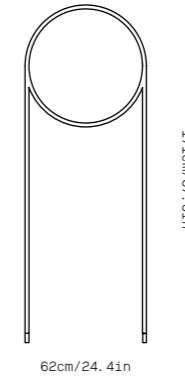

(EN)  
Metal structure with cork feet. Black or white finish

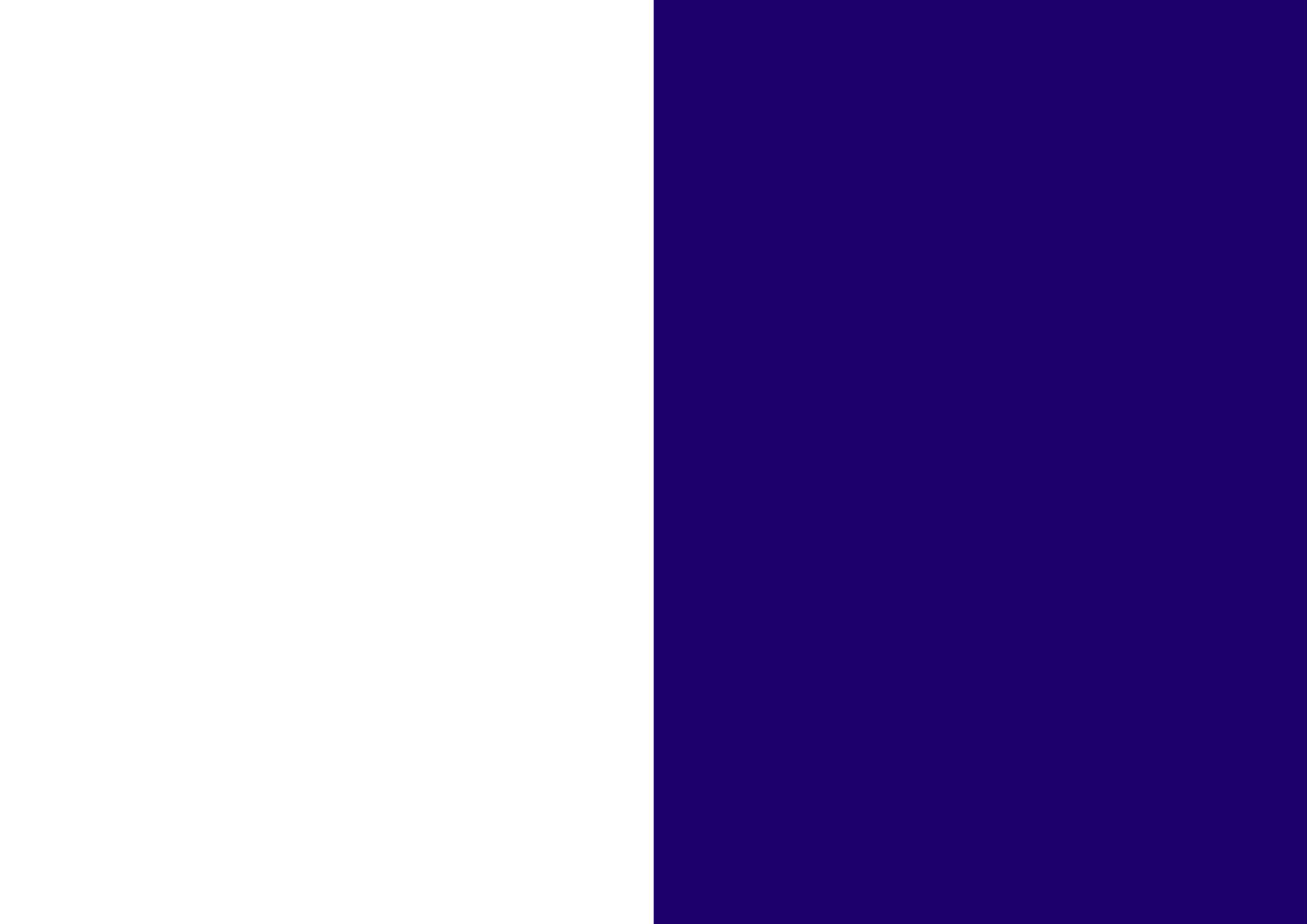

# omelette books