

BOS
1964
BARCELONA

The executive
furniture company

EXECUTIVE BOOK
DESPACHOS BOOK
Version 2.0



WELCOME TO BOS1964

We are The Executive Furniture Company and provide beauty and sophistication to the executive floor.

BIENVENIDO A BOS1964

Somos la empresa de mobiliario de dirección que integra diseño y máxima calidad en las áreas ejecutivas.

What we do Qué hacemos

We call ourselves The Executive Furniture Company as we are exclusively dedicated to the executive floor where we have 3 KEY focus areas of expertise which always come with a very high level of finishes. At BOS1964 we take pride in bringing the best and most exclusive finishes in natural wood veneers, top Grain European cowhides and piano lacquer finishes. We are very flexible and will usually be able to accommodate any special request in finishes.

Nos llaman "la empresa de mobiliario de dirección" por nuestra dedicación en exclusiva a las distintas soluciones y necesidades de 3 grandes áreas ejecutivas: mesas de dirección, productos tapizados y mesas de juntas. BOS1964 ofrece una gama de acabados y materiales de máxima calidad en madera, piel, metal, lacas y barnices y una gran flexibilidad de adaptación a las necesidades requeridas en cada proyecto.



- 2) Upholstered armchairs and sofas for executive offices, meeting rooms, VIP areas or hotel lobby.
- 2) Sillones y Sofás tapizados para despachos ejecutivos, salas de juntas, zonas VIP o el lobby de un hotel.

- 1) Executive desking for the closed executive office with solutions for chairmans, CEO's, directors and managers.

1) Mesas de dirección creadas para los despachos de ejecutivos y consejeros delegados.



- 3) Conferences tables. Solutions that range from small meeting tables to large boardroom tables integrated in different spaces and with a wide variety of technical, technological and multimedia options according to needs.

3) Mesa de juntas. Soluciones que van desde las pequeñas mesas de reunión hasta las grandes mesas de consejo, integradas en espacios diversos y con una gran variedad de opciones técnicas, informáticas y de sonido según necesidades.

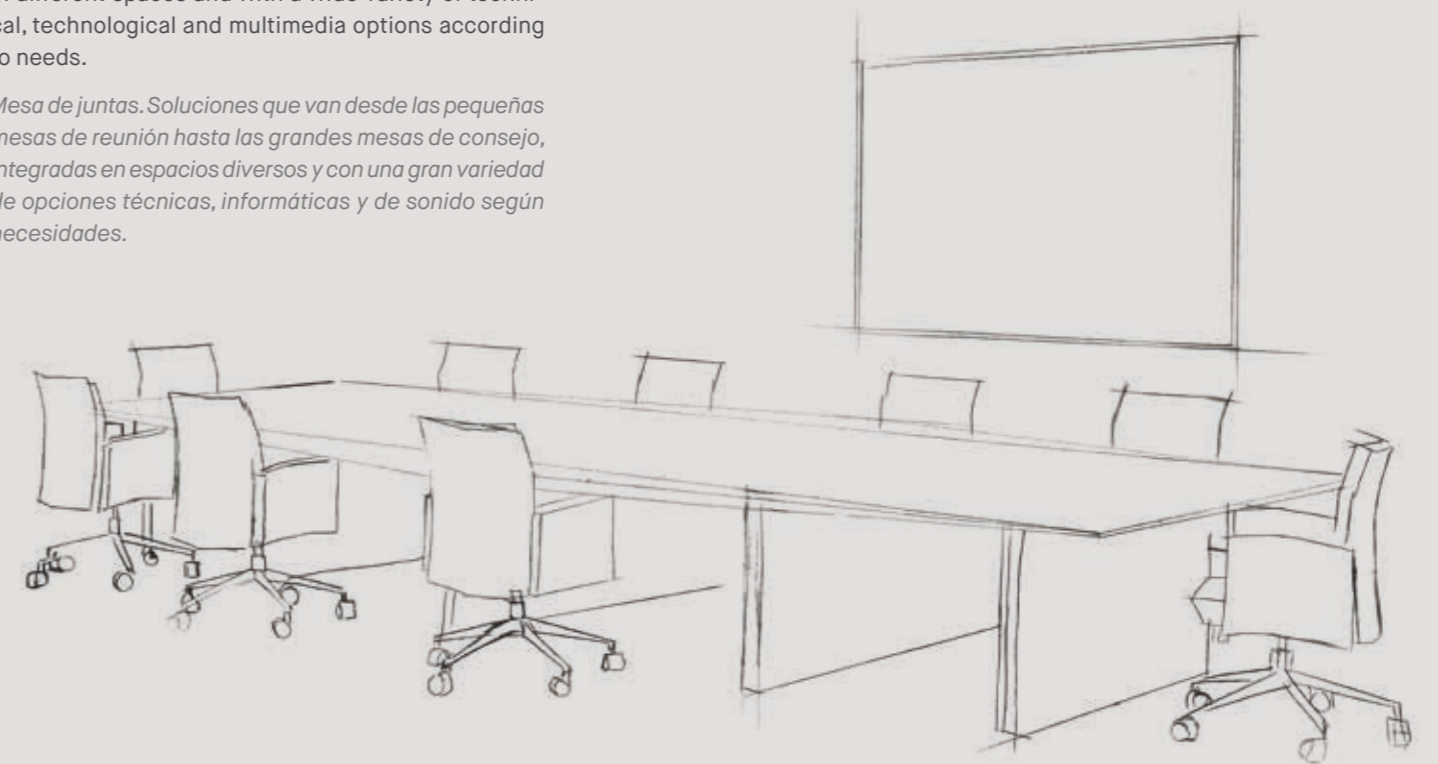



Both have made it. All generations since then have considered their collections to be current and at the forefront in creating contemporary classics.

Ambos lo han conseguido. Todas las generaciones desde esta fecha han considerado siempre actuales sus colecciones que han sido punteras desde los inicios y siguen en primera línea en la actualidad.

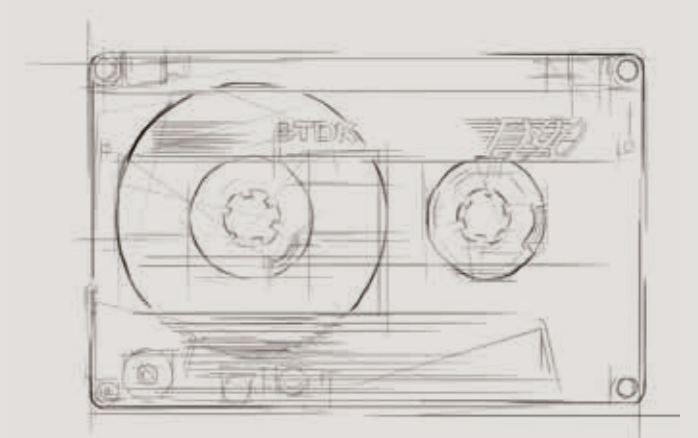
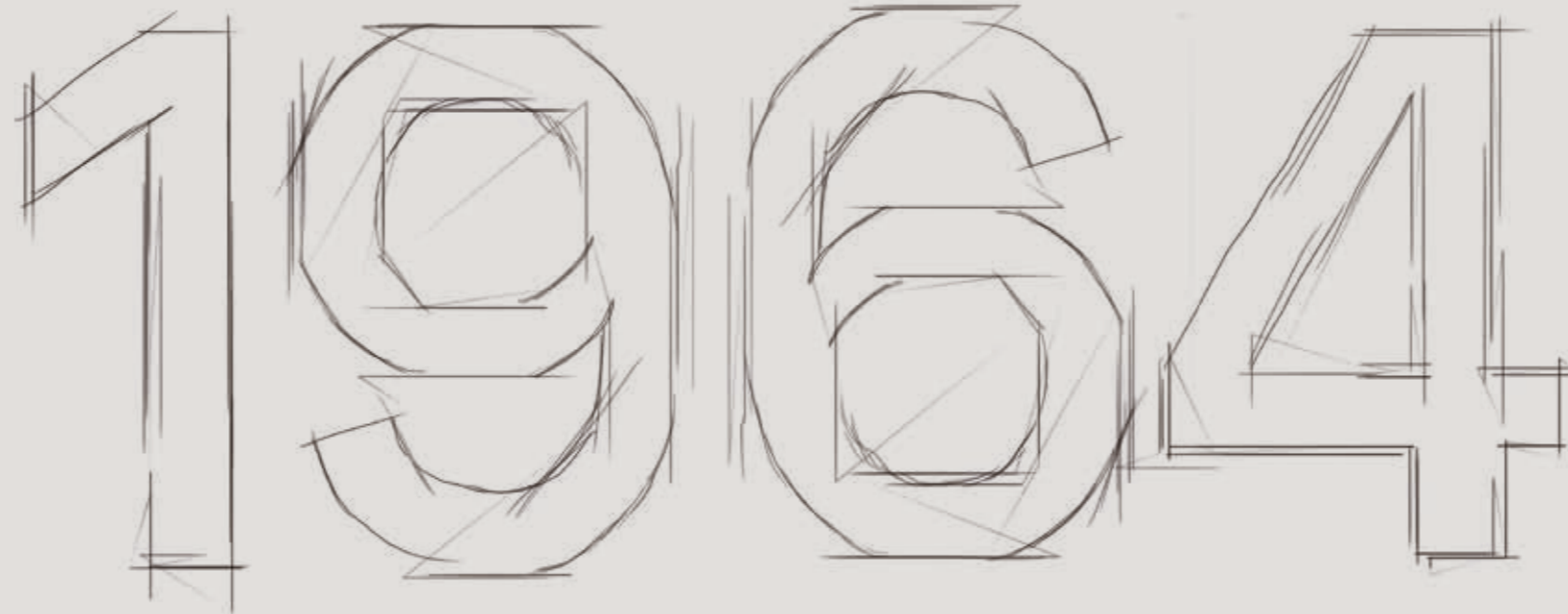

As the cassette revolutionized the world of music, making it possible to listen to your favorite artists anytime and anywhere, BOS1964 has revolutionized the world of top management furniture achieving status as the preferred choice globally.

Como el casete revolucionó el mundo de la música permitiendo escuchar a tus preferidos en cualquier lugar y en cualquier momento, BOS1964 ha revolucionado el mundo del mobiliario de alta dirección haciendo que sus productos sean los preferidos en todos los mercados internacionales.

The Olympic spirit is the spirit of BOS1964. International above all. Collections for all countries with capacity to satisfy and combine very diverse aspects that are valid for all continents.

El espíritu de una olimpiada es el espíritu de BOS1964. Internacionalidad por encima de todo. Colecciones para todos los países, capaces de satisfacer y conjugar los aspectos más diversos, válidos para cualquier continente.

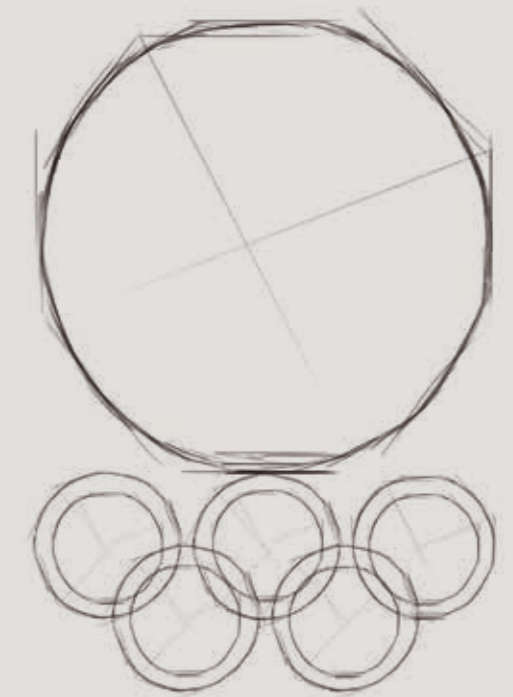

TOKYO 1964



Contemplating products from BOS1964 is like looking at a Mercedes. Prestige, highest quality and long-lasting. An office from BOS1964 is, by its finishes and quality, contemporary and a guarantee of the highest level.

Contemplar los productos de BOS1964 es como contemplar un Mercedes. Prestigio, calidad y perdurabilidad en el tiempo. Un despacho de BOS1964 siempre es actual por sus acabados y calidad. Hablar de BOS1964 es hablar de máximo nivel.

Expertise Pericia

BOS1964 belongs to a limited circle of office furniture manufacturers where product perfection is a core value and a continuous search. Therefore, since its founding, BOS1964 controls all production processes: from the purchase and selection of the best natural wood veneers and cow hides to the pre-assembly and distribution. With a strict care of the finishes, all the woods are worked by hand and the final product always has a serial number to keep track of it and guarantees a personalized after sales service. This is part of our total client satisfaction focus.

BOS1964 pertenece a un reducido círculo de fabricantes de muebles que, fiel a sus valores, busca la perfección de sus productos. Por ello, y desde que se fundó la firma, BOS1964 controla todos los procesos de producción: desde la compra y selección directa de las mejores maderas y pieles hasta su montaje previo y distribución. Con un cuidado estricto de los acabados, todas las maderas se trabajan a mano y el producto final siempre lleva un número de serie para hacer un seguimiento del mismo y ofrecer un servicio de posventa personalizado que garantice la total satisfacción de nuestros clientes.

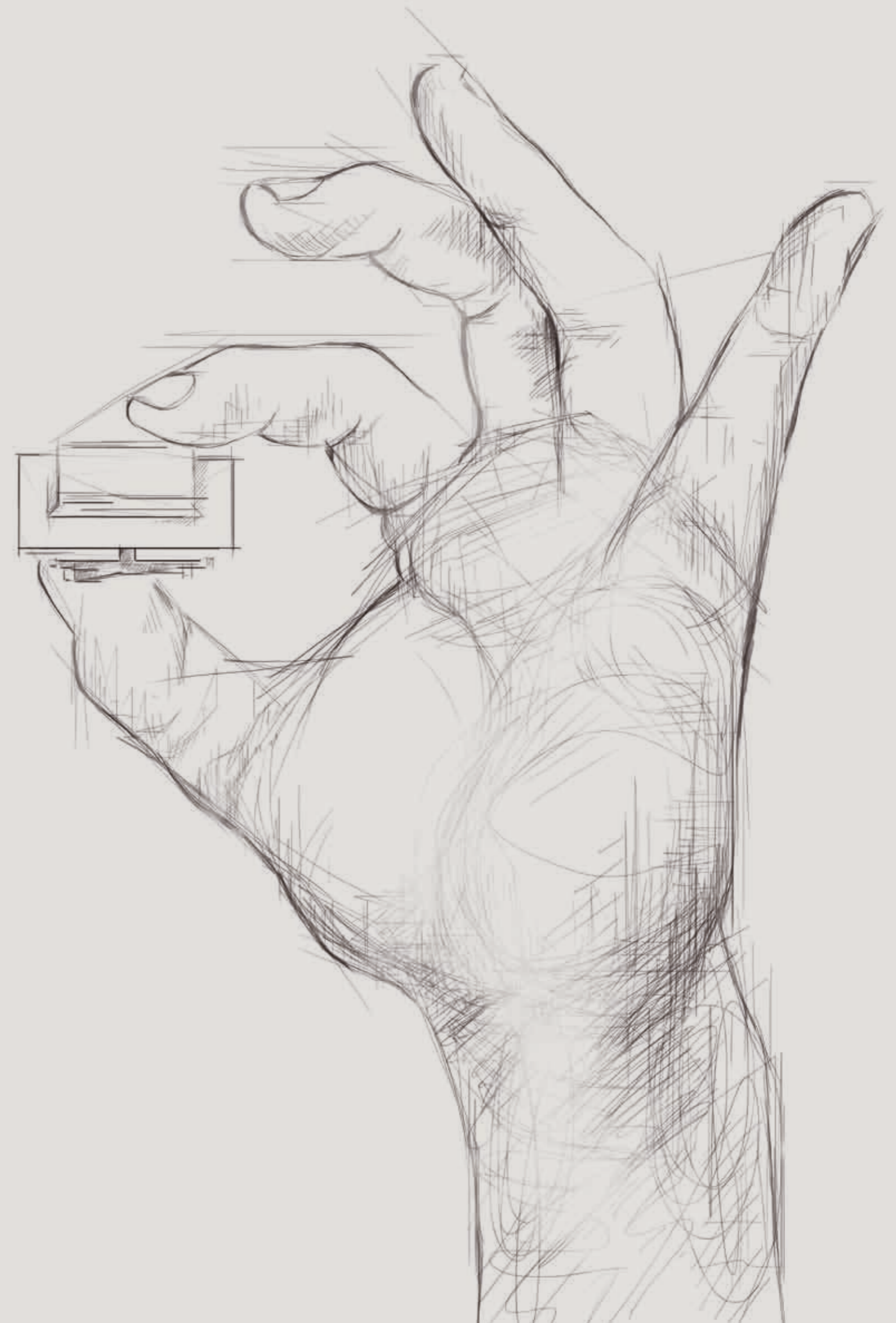

Designers Diseñadores

One of our main objectives is to find a perfect balance between classic and modern designs that ensures durability as well as icons in terms of handcraft and innovation. This is achieved thanks to our dynamic multicultural team which, by combining top-notch technology and strong expertise in traditional manufacturing, is able to provide unique and exclusive solutions to meet the needs of our most demanding clients. Our ambition to maintain leadership in executive office furniture drives us to continually innovate in providing highly resilient furniture of supreme quality.

Uno de los principales objetivos es encontrar el equilibrio perfecto entre el clasicismo y la modernidad para que nuestros productos perduren con el paso del tiempo y se conviertan en un icono de artesanía e innovación. Esto se consigue gracias a un equipo dinámico y multicultural que, combinando la tecnología de última generación con los conocimientos de la manufactura tradicional, puede seguir ofreciendo soluciones exclusivas y únicas a la altura de las necesidades más exigentes. Nuestra ambición por ser un referente en mesas de despacho, mesas de reuniones y sillas de dirección es lo que nos inspira para seguir innovando y ofrecer muebles con una durabilidad y calidad suprema.



Sørig

Born in Denmark and develops his professional activity as "Industrial designer". Starts his studies at "Kunstakademiet Arkitektsskole" and at the "Aarhus school of architecture" building his own business in 1995 "Sørig Designstudio". Works for different sectors and known brands such as Bang&Olufsen and Swarovski, gaining different prizes such as IF Cebit Award 1995, Las Vegas Best of show, 2000.

Nace en Dinamarca y desarrolla su actividad profesional como "diseñador industrial". Empieza su formación en "Kunstakademiet Arkitektsskole" y en la "Aarhus school of architecture" montando su propio estudio en 1995 "Sørig Designstudio". Trabaja para distintos sectores destacadas y marcas como Bang&Olufsen y Swarovski, cosechando diversos premios como IF Cebit Award 1995, Las Vegas Best of show, 2000.



Arola

Born in Tarragona in 1960 and starts his professional career at the studio "Lievore y Pensi" and later at "AD Associate Designers". Starts his own studio in 1994 "Estudio Arola" In parallel with his business he also gives classes at the university. Won several prizes Silver Delta Prize, 1999 and 2001, National design price, 2003, Price I Plus, 2009, Reddot award, 2012 and is honorable member of the design organization APPI.

Nace en Tarragona en 1960 e inicia su carrera profesional en el estudio "Lievore y Pensi" y posteriormente en "AD Associate Designers" fundando su propio estudio en 1994 "Estudio Arola". Compagina su carrera profesional con la docencia y ha cosechado diversos premios. Premio Delta de plata 1999 y 2001, Premios nacional de diseño en 2003, Premio I Plus 2009, Red Dot Award 2012 y nombrado "soci d' honor APPI".



Pensi

Leaves his natal country Argentina in 1975 and establishes himself in Barcelona in 1984 and creates "Jorge Pensi Design Studio". Has given conferences and workshops all around the world. He and his designs have received several prizes among which is the Spanish design prize in 1997.

Deja su país de origen Argentina en 1975, se establece en Barcelona en 1984 y crea su propio studio "Jorge Pensi Design Studio" Jorge Pensi ha dictado conferencias, seminarios y workshops en distintos lugares del mundo. Él y sus productos han cosechado diversos premios, entre ellos el premio nacional de diseño en 1997 en España.



Danesi

Italian designer born in Bolzano in 1948. Starts his career at the architect studio "Baniera e Facchini" and concentrates his activity mainly in Office furniture projects. Starts his own business in 1980 as product designer and art director as well as consultant for international companies in the office sector.

Es un diseñador Italiano nacido en Bolzano en 1948. Empieza su carrera profesional en el estudio de los arquitectos "Bandiera e Facchini" y centra su actividad primordialmente en los proyectos de sistemas de oficina. Funda su propio estudio en 1980 como product designer, art director y asesor para empresas del sector de oficinas, italianas y extranjeras.



BOS Barcelona Design Team

BOS Barcelona Design Team is made up of designers and Project developers with accumulated experience far beyond their own, as they continue a design tradition that dates back to 1939. This is the BOS1964 design cradle from which accumulated knowledge has made possible the products that BOS1964 offers today.

BOS Barcelona Design Team es un equipo de diseñadores y proyectistas que ostentan una dilatada experiencia muy superior a la de su propia existencia como continuadores de grandes equipos de diseño del pasado existentes desde 1939 de cuya enseñanza se han beneficiado consiguiendo los productos que BOS1964 ofrece en la actualidad.

International Internacional

An international focus has always been a priority at BOS Barcelona. We have a background of over 30 years' experience exporting to some 40 countries around the world, and we continue our nonstop striving to reach new markets. We have been providing impeccable service for many years now, where the infinite innovative solutions for clients throughout the world endorse and support this claim.

El enfoque internacional siempre ha sido una prioridad en BOS Barcelona. Contamos con una larga trayectoria de más de 30 años exportando a más de 40 países en todo el mundo, y continuamos sin cesar en nuestro esfuerzo por alcanzar nuevos mercados.

Llevamos muchos años ofreciendo un servicio impecable y nos avalan infinidad de soluciones innovadoras para clientes de ámbito mundial.

Dubai
Dubai

Cairo
El Cairo

Brussels
Bruselas

Doha
Doha

Bahrain
Baréin

Kuwait
Kuwait

Muscat
Mascat

Moscow
Moscú

St. Petersburg
St. Petersburgo

Warsaw
Varsovia

Barcelona
Barcelona

Lisbon
Lisboa

Astana
Astaná

Geneva
Ginebra

Almaty
Almaty

Sofia
Sofía

Athens
Atenas

Luxemburg
Luxemburgo

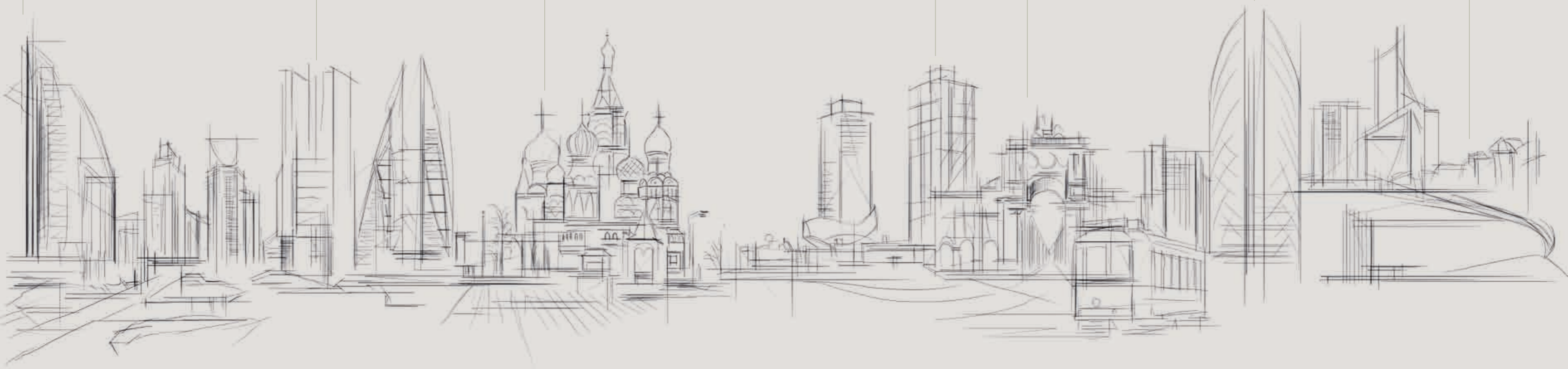

Presidential desks
Mesas presidenciales

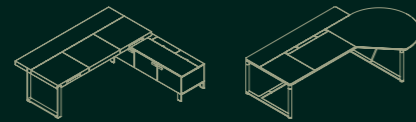

016 Touring

042 Diktat

01

Management desks
Mesas de dirección

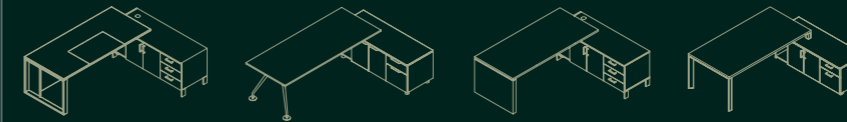

106 Supra

122 Sail

136 Lead

148 Kubo

03

Chairs & sofas
Sillas y sofás

160

04

Top management desks
Mesas de alta dirección

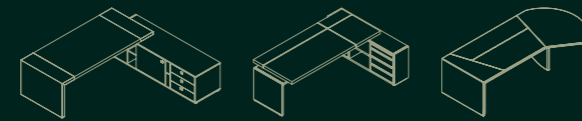

060 Aqua

080 Karan

092 Avant

02

Bookcases
Librerías

172

05

Technology
Tecnología

173

06

Occasional tables
Mesas de centro

182

07

Presidential desks
Mesas presidenciales

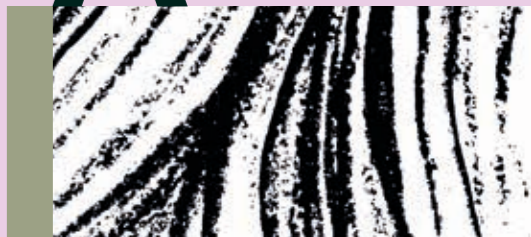

PRESDITTLL
S

Our most presidential collection
Nuestra colección más presidencial

Design / *Diseño*:
Danesi

Touring

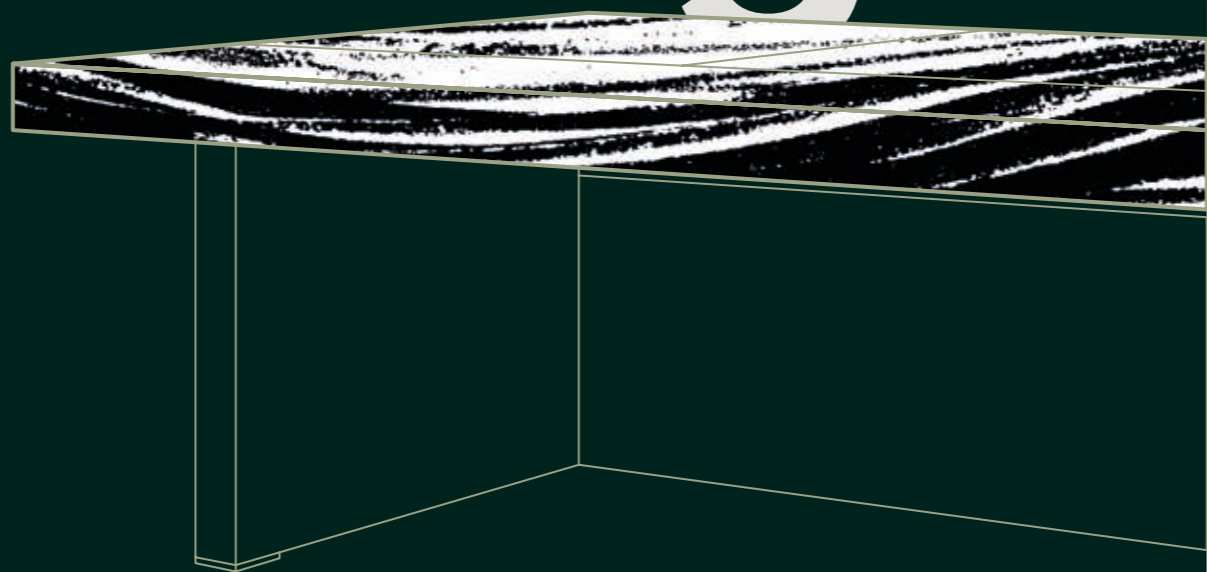























Abu Dhabi Sports Council
U.A.E



MHD Group
OMAN

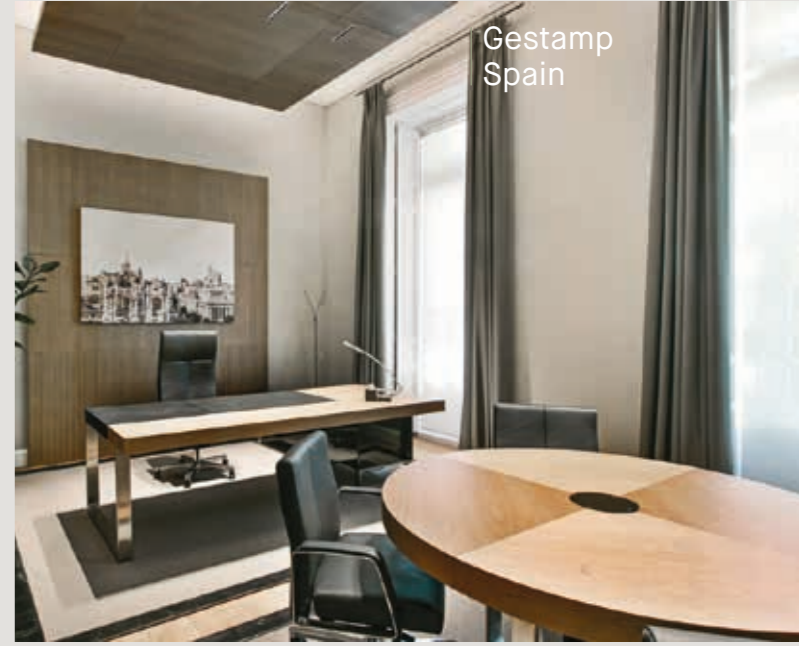

Gestamp
Spain



Family Investment Office
KSA



Ministry of Economy
Qatar



ADSIC
U.A.E



SCA
U.A.E



Intercontinental Hotel
Egypt



British American Tobacco
Ukraine

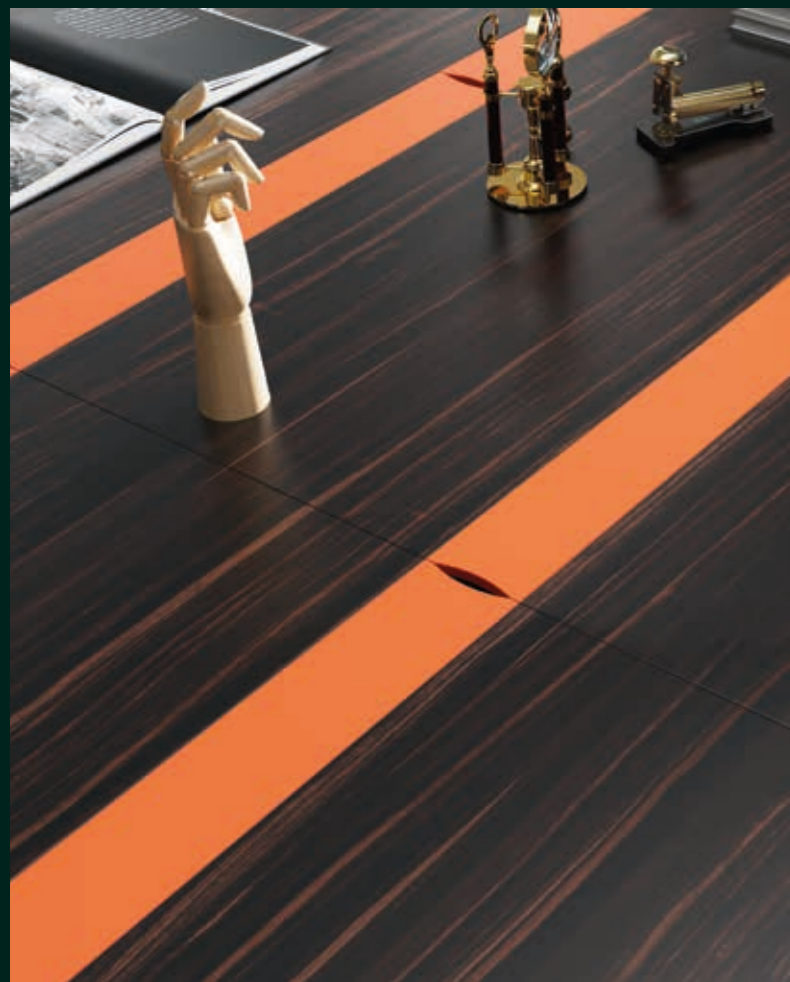

TECHNICAL INFORMATION
INFORMACIÓN TÉCNICA

Table top
Sobre

Thickness
Grosor

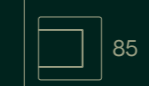

Finishes
Acabados
Wood / Madera
Lacquer / Lacado
Leather / Piel

Legs
Patas

80
Wood / Madera

80
Inox

Office tables
Mesas de despacho

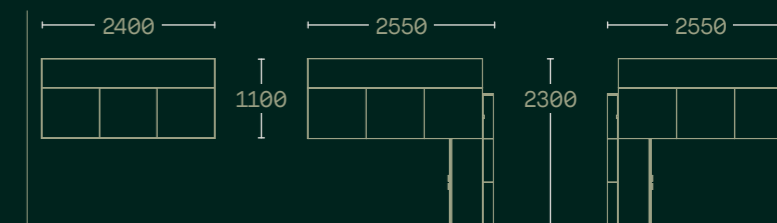

Meeting tables
Mesas de reuniones



Coffee tables
Mesas de centro



Recommended bookcases: Luxury
Armarios recomendados: Luxury

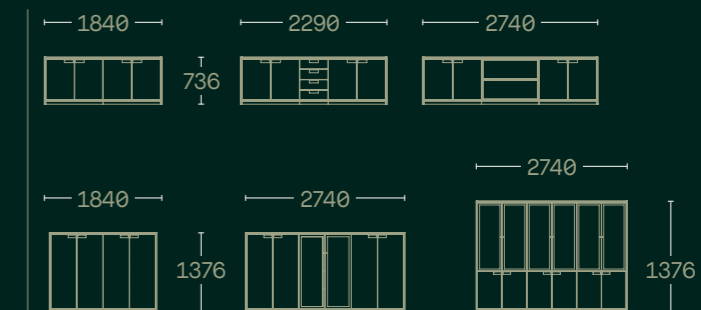

Amazing combinations of all our high end finishes
Perfecta combinación de acabados de máxima calidad

Design / *Diseño:*
Danesi

Diktat

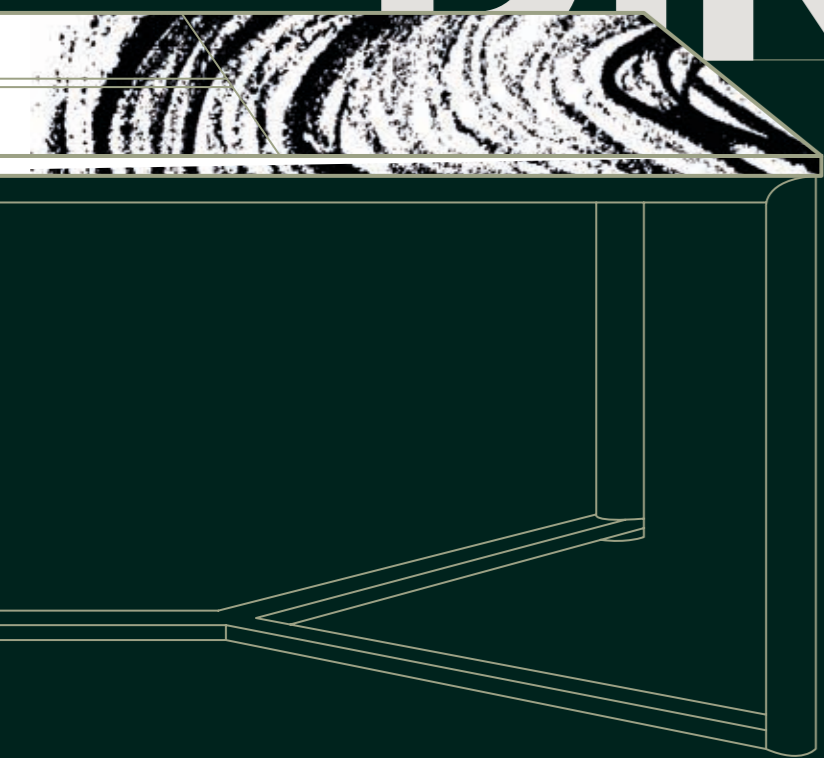













Visor Capital
Kazakhstan



Santander Private Banking
Europe



Abu Dhabi Sports Council
U.A.E

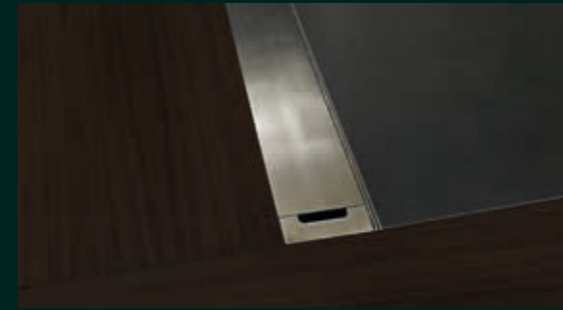

TECHNICAL INFORMATION
 INFORMACIÓN TÉCNICA

Table top
 Sobre

Thickness
 Grosor
 19+19

Finishes
 Acabados
 Wood / Madera
 Lacquer / Lacado
 Leather / Piel
 Glass / Cristal

Legs
 Patas

Ø50
 Inox / Inoxidable
 Bright paint / Pintura brillante

Office tables
 Mesas de despacho

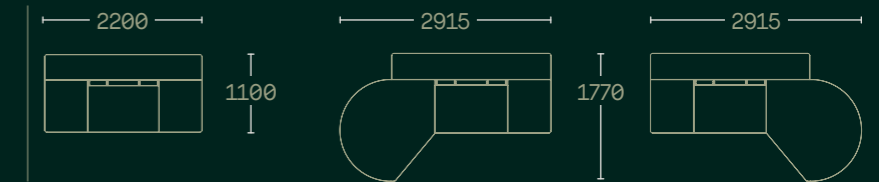

Meeting tables
 Mesas de reuniones

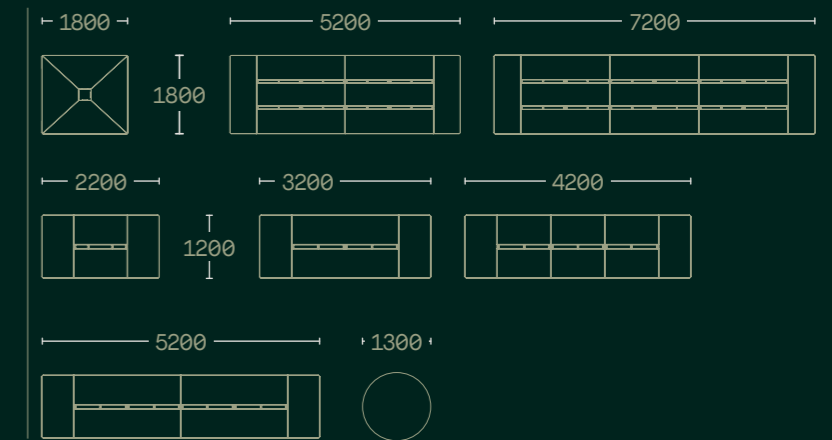

Coffee tables
 Mesas de centro

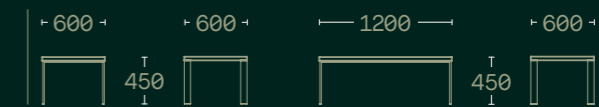

Recommended bookcases: Luxury
 Armarios recomendados: Luxury



Top management desks
Mesas de alta dirección

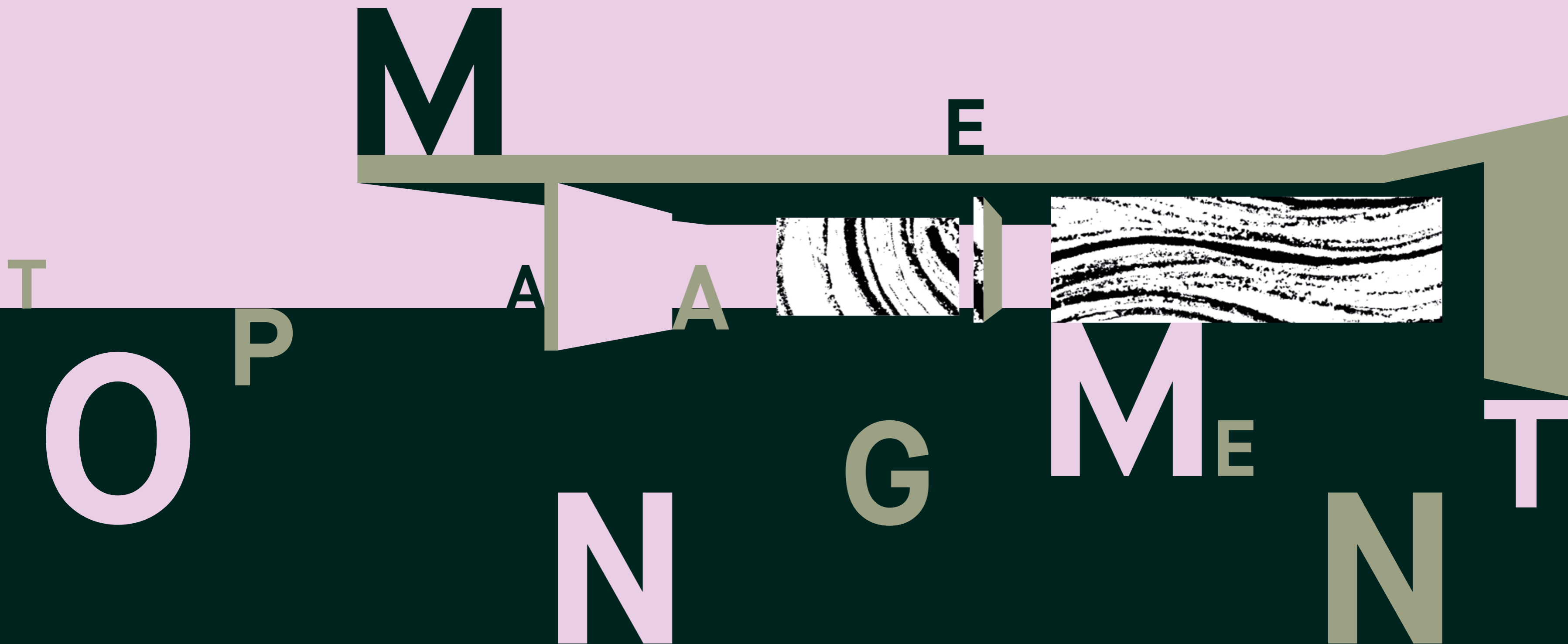

For the refined and distinctive CEO
Refinada elegancia para despachos de gerencia

Design / *Diseño:*
Danesi

Aqua

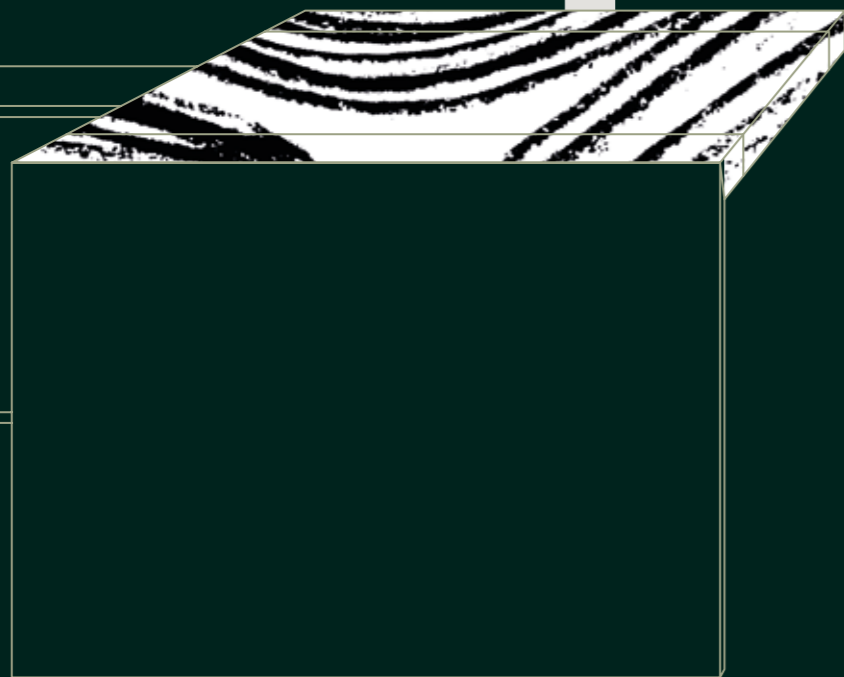

















Gulf agency
Cyprus



British American Tobacco
Ukraine

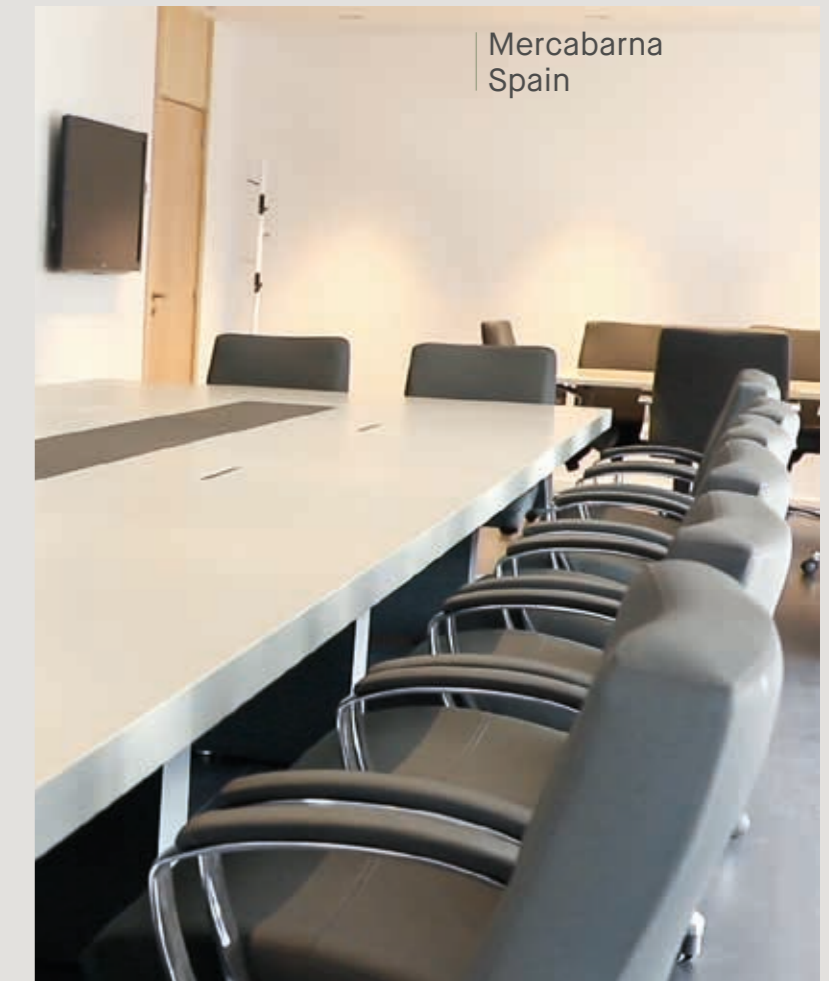

Mercabarna
Spain



TECHNICAL INFORMATION
INFORMACIÓN TÉCNICA

Table top
Sobre

Thickness
Grosor
60

Finishes
Acabados
Wood / Madera
Lacquer / Lacado

Legs
Patas

60
Wood / Madera
Lacquer / Lacado

Office tables
Mesas de despacho

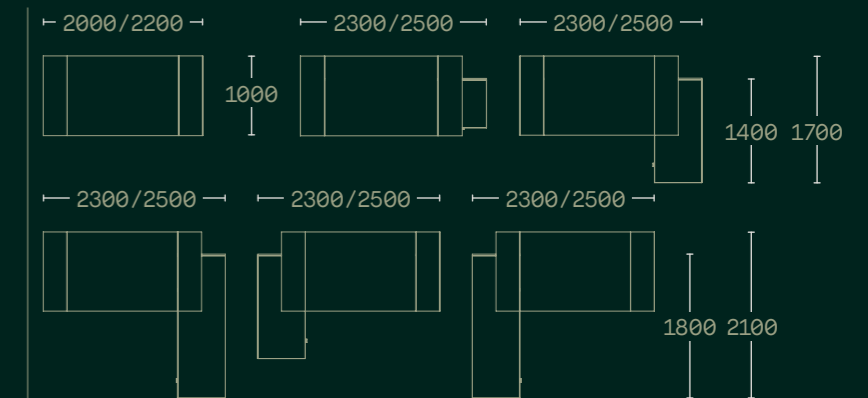

Meeting tables
Mesas de reuniones

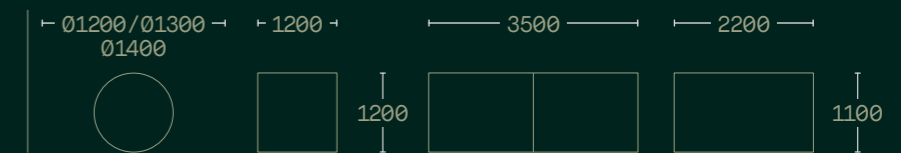

Coffee tables
Mesas de centro



Recommended bookcases: Premium
Armarios recomendados: Premium

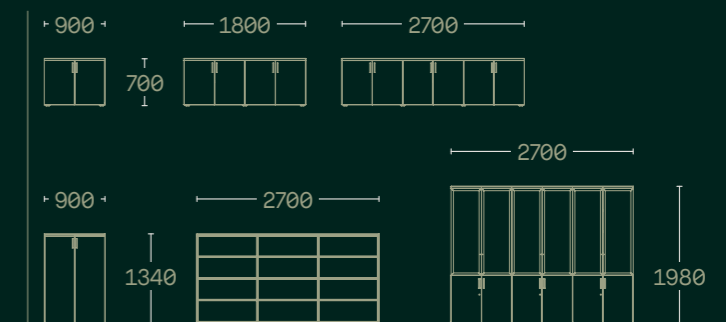

Architectural and robust appealing to our senses
Perfecta imagen de robustez arquitectónica

Design / *Diseño:*
Arola

Karan

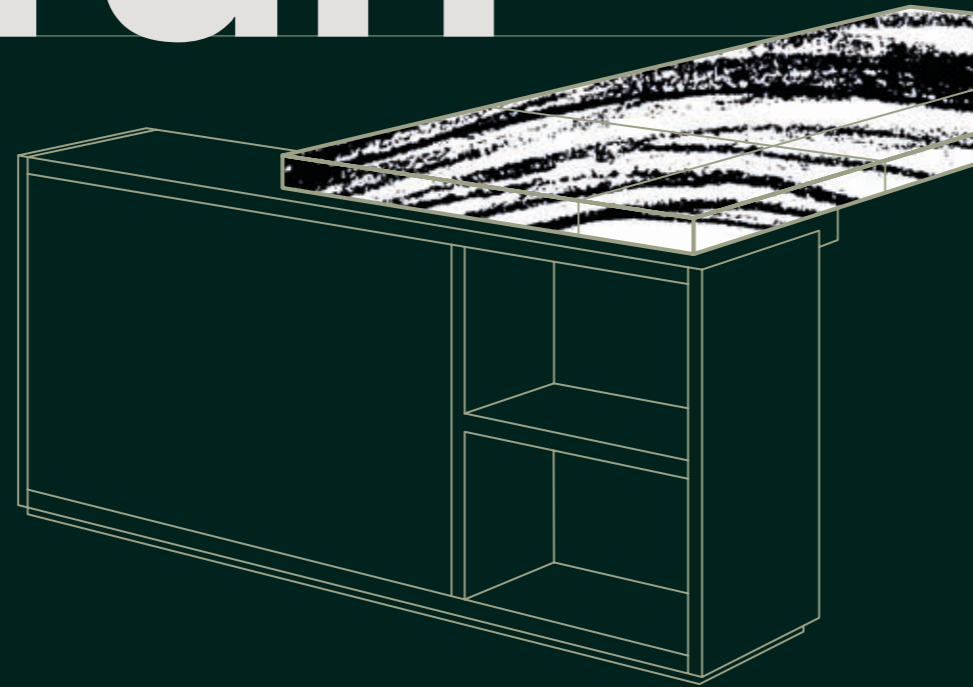









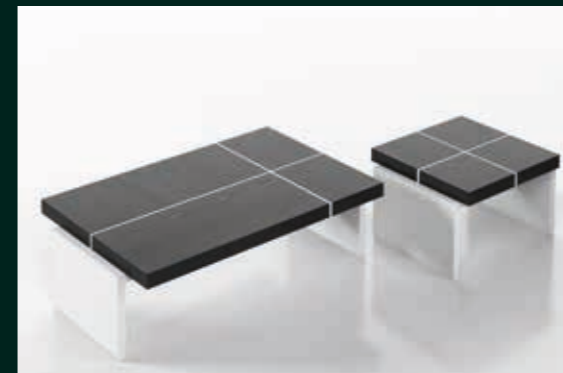

TECHNICAL INFORMATION
INFORMACIÓN TÉCNICA

Table top
Sobre

Thickness
Grosor
60

Finishes
Acabados
Wood / Madera

Legs
Patas

60
Wood / Madera
Lacquer / Lacado

Office tables
Mesas de despacho

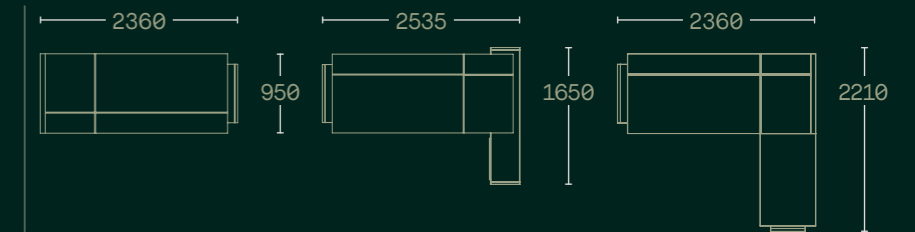

Meeting tables
Mesas de reuniones

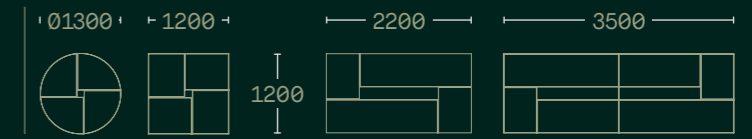

Coffee tables
Mesas de centro



Recommended bookcases: Premium
Armarios recomendados: Premium

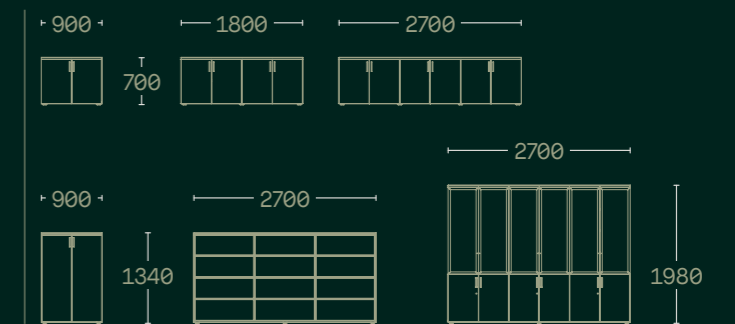

A classic everlasting in time
Un clásico perdurable en el tiempo

Design / Diseño:
Danesi

Avant

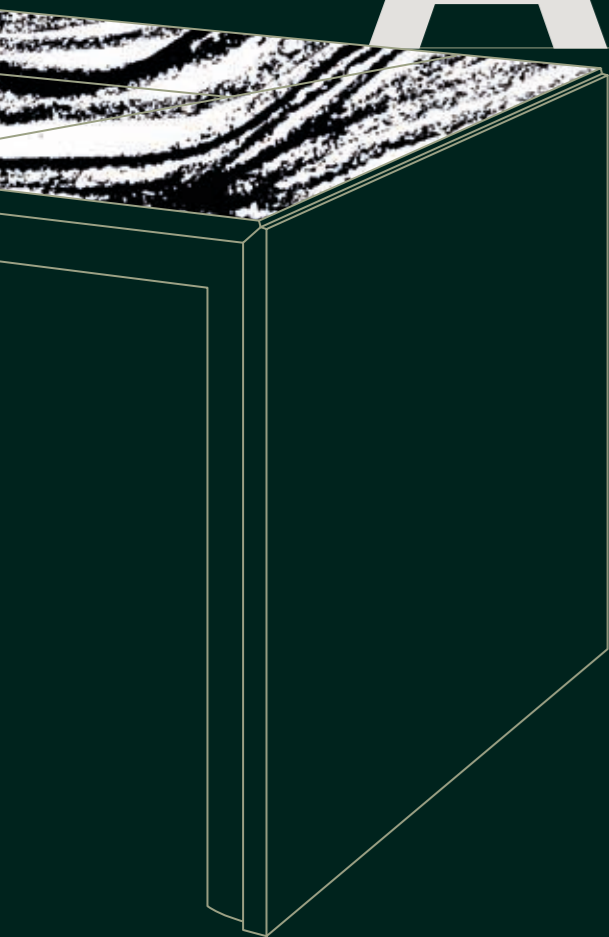

BOS1964
96 - 97

Top management desks
Mesas de alta dirección

Aqua
Karan
Avant





BOS1964
100 - 101

Top management desks
Mesas de alta dirección

Aqua
Karan
Avant



BOS1964
102 - 103

Top management desks
Mesas de alta dirección

Aqua
Karan
Avant





TECHNICAL INFORMATION
INFORMACIÓN TÉCNICA

Table top
Sobre

Thickness
Grosor
25+65

Finishes
Acabados
Lacquer / Lacado
Leather / Piel

Legs
Patas

140
Lacquer / Lacado

Office tables

Mesas de despacho

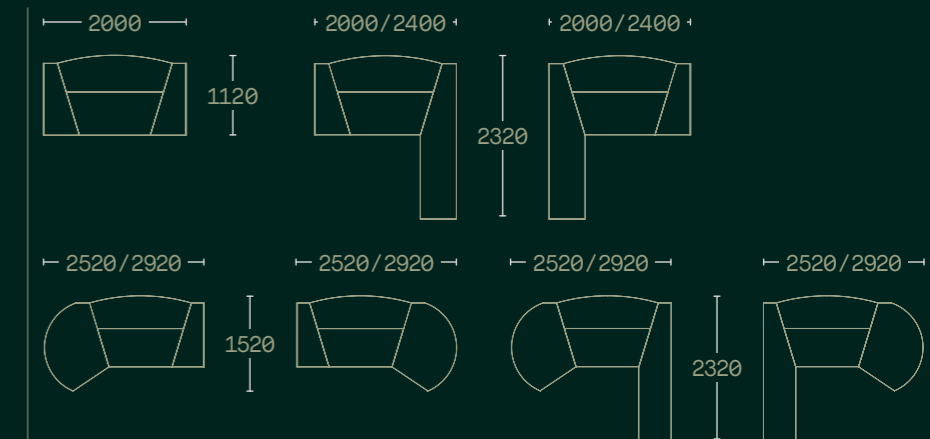

Meeting tables

Mesas de reuniones

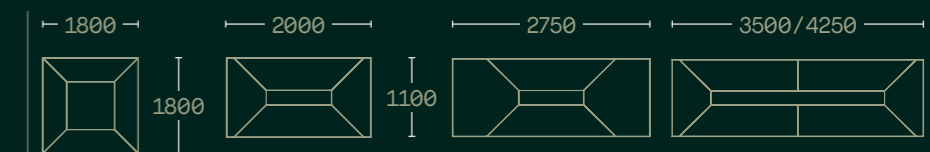

Coffee tables

Mesas de centro



Recommended bookcases: Premium

Armarios recomendados: Premium

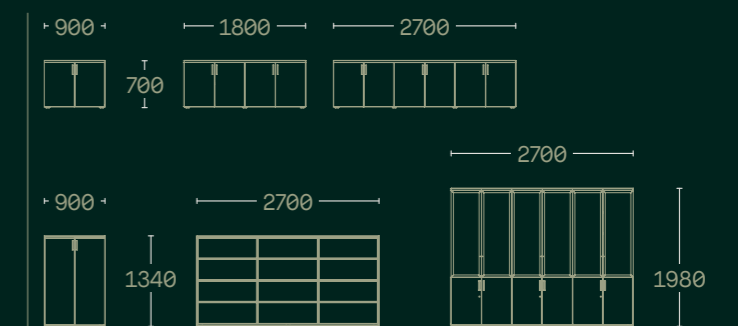

Management desks
Mesas de dirección

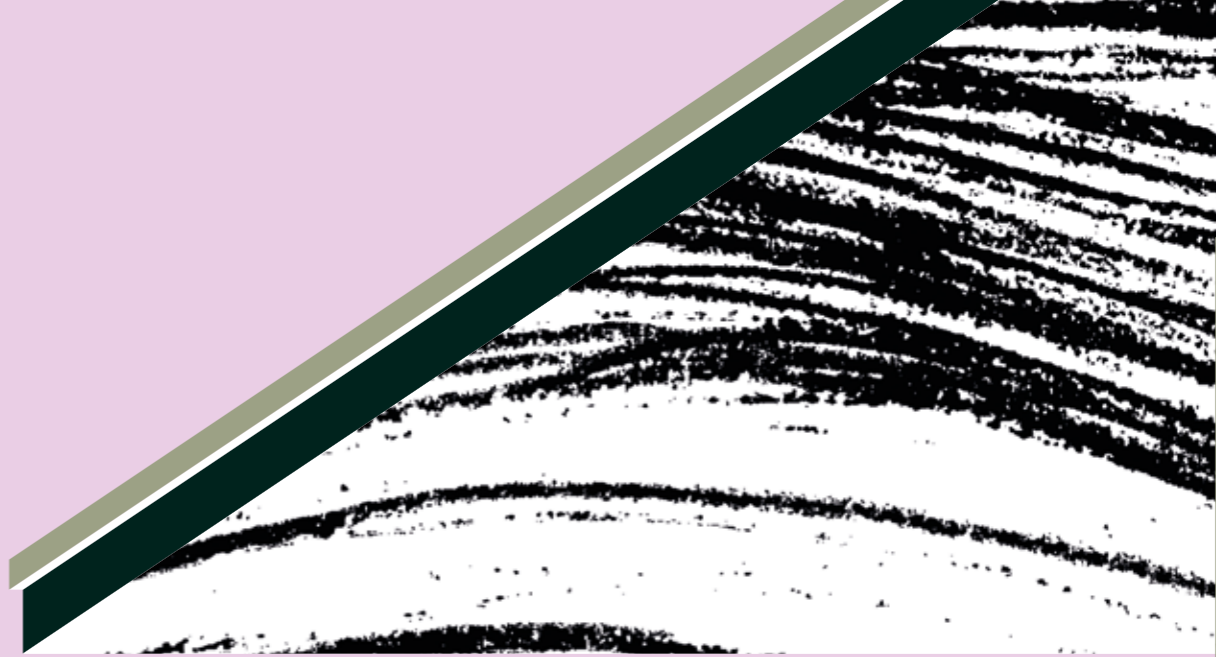

A

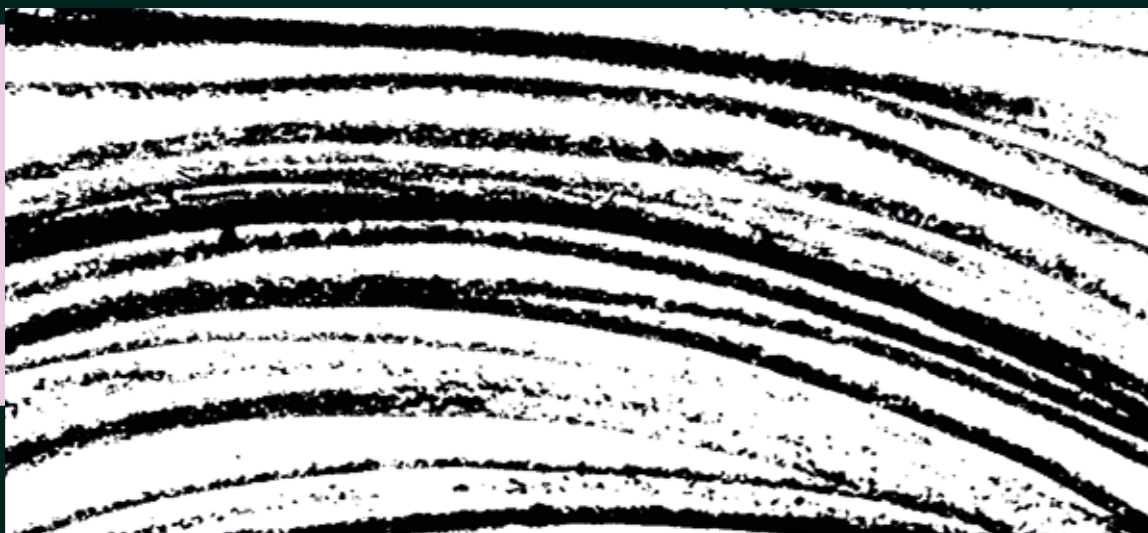

M

G

M

T

E

E

A

N

N

For the demanding client appreciating modern lines
Diseño de líneas modernas y exigentes

Design / *Diseño:*
Danesi

Supra

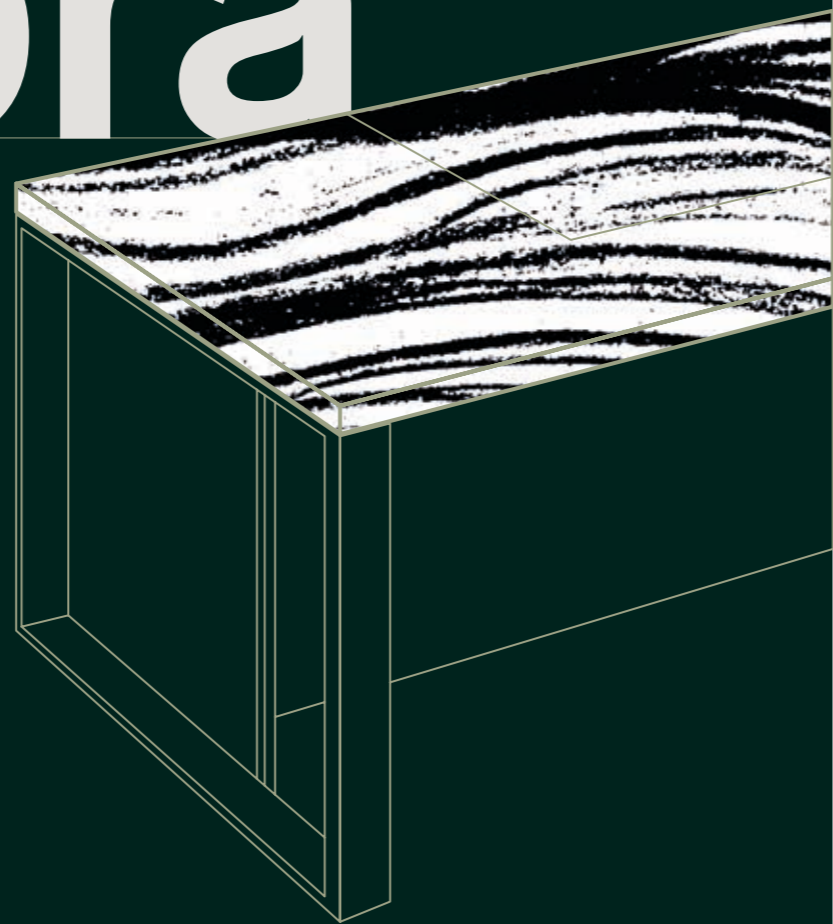

BOS1964
110 - 111

Management desks
Mesas de dirección

Supra
Sail
Lead
Kubo



BOS1964
112 - 113

Management desks
Mesa de dirección

Supra
Sail
Lead
Kubo





BOS1964
116 - 117

Management desks
Mesas de dirección

Supra
Sail
Lead
Kubo









TECHNICAL INFORMATION
INFORMACIÓN TÉCNICA

Table top
Sobre

Thickness
Grosor



30

Finishes
Acabados

Wood / Madera
Lacquer / Lacado
Leather / Piel

Legs
Patas



70

Metallic / Metálico

Office tables

Mesas de despacho

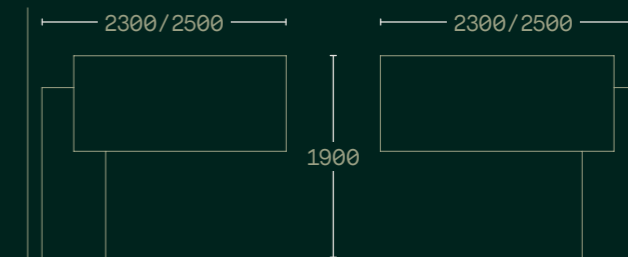

Meeting tables

Mesas de reuniones

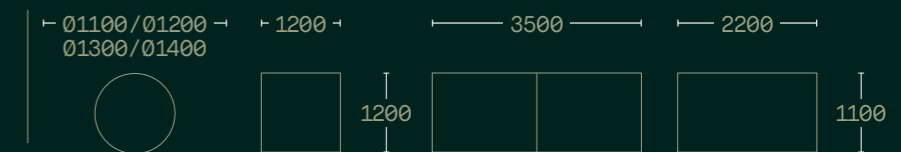

Coffee tables

Mesas de centro



Recommended bookcases: Standard (laminated)

Armarios recomendados: Standard (carcasa de melamina)

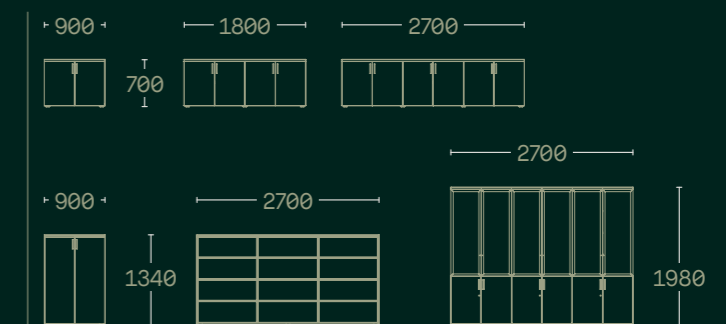

BOS1964
124 - 125

Management desks
Mesas de dirección

Supra
Sail
Lead
Kubo

Minimalist lines and lightweight feel
Líneas minimalistas y aire ligero

Design / *Diseño:*
BOS.DT

Sail

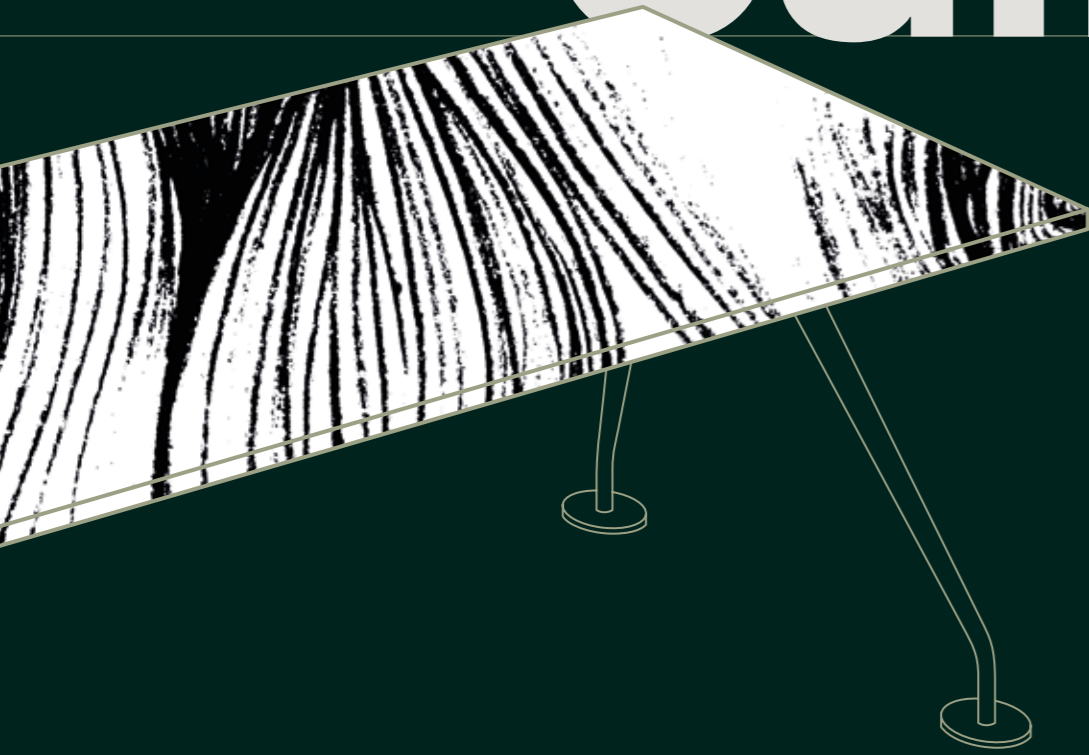

BOS
1964
BARCELONA



BOS1964
126 - 127

Management desks
Mesas de dirección

Supra
Sail
Lead
Lubo







BOS1964
132 - 133

Management desks
Mesas de dirección

Supra
Sail
Lead
Kubo



BOS1964
134 - 135

Management desks
Mesas de dirección

Supra
Sail
Lead
Kubo



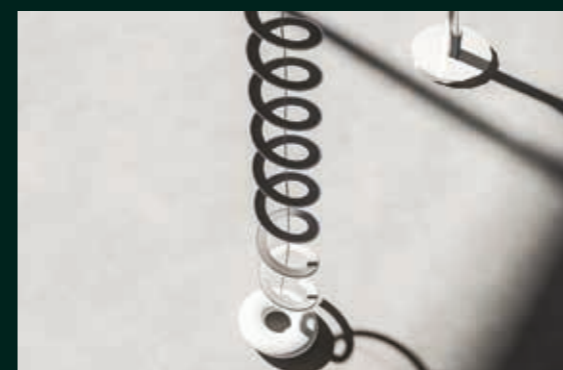

TECHNICAL INFORMATION
INFORMACIÓN TÉCNICA

Table top
Sobre

Thickness
Grosor



Finishes
Acabados

Wood / Madera
Lacquer / Lacado
Leather / Piel
Glass / Cristal

Legs
Patas



Metallic / Metálico

Office tables

Mesas de despacho

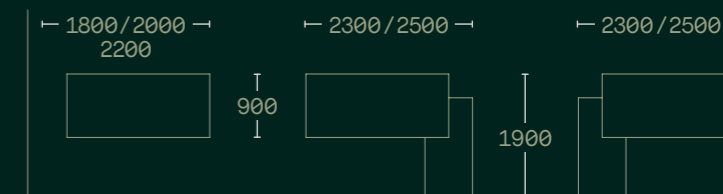

Meeting tables

Mesas de reuniones



Coffee tables

Mesas de centro



Recommended bookcases: Standard (laminated)

Armarios recomendados: Standard (carcasa de melamina)

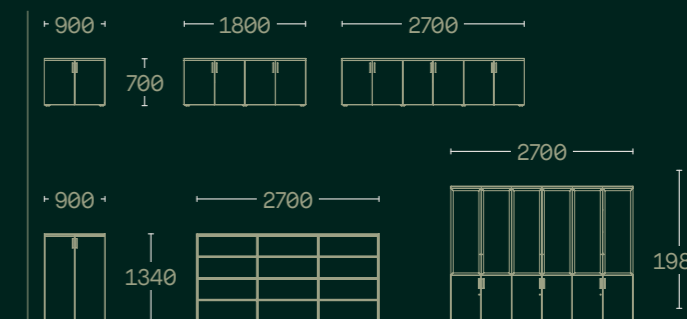

BOS1964
138 - 139

Management desks
Mesas de dirección

Supra
Sail
Lead
Kubo

Perfect expression of the desired objective
Perfecta expresión del objetivo buscado

Design / *Diseño:*
BOS.DT

Lead



BOS
1964
BARCELONA

BOS1964
140 - 141

Management desks
Mesas de dirección

Supra
Sail
Lead
Kubo





BOS1964
144 - 145

Management desks
Mesas de dirección

Supra
Sail
Lead
Kubo







TECHNICAL INFORMATION
INFORMACIÓN TÉCNICA

Table top
Sobre

Thickness
Grosor

30

Finishes
Acabados
Wood / Madera
Lacquer / Lacado
Leather / Piel

Legs
Patas

70

Wood / Madera
Lacquer / Lacado

Office tables

Mesas de despacho

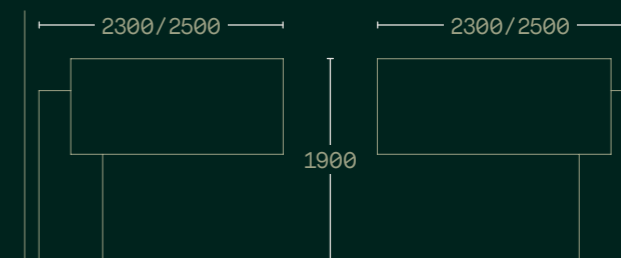

Meeting tables

Mesas de reuniones



Coffee tables

Mesas de centro



Recommended bookcases: Standard (laminated)

Armarios recomendados: Standard (carcasa de melamina)

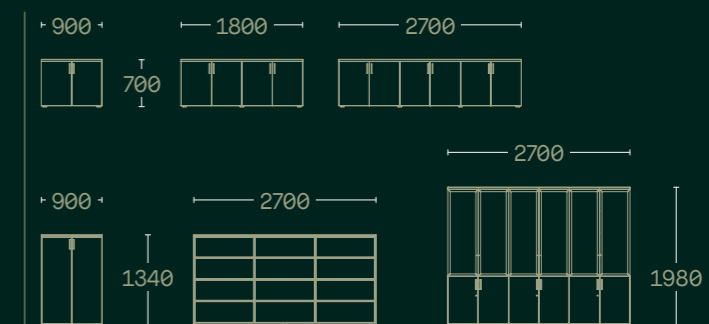

BOS1964
150 - 151

Management desks
Mesas de dirección

Supra
Sail
Lead
Kubo

Minimalistic and rational with dynamic solutions
Minimalista y racional con soluciones dinámicas

Design / *Diseño*:
BOS.DT

Kubo

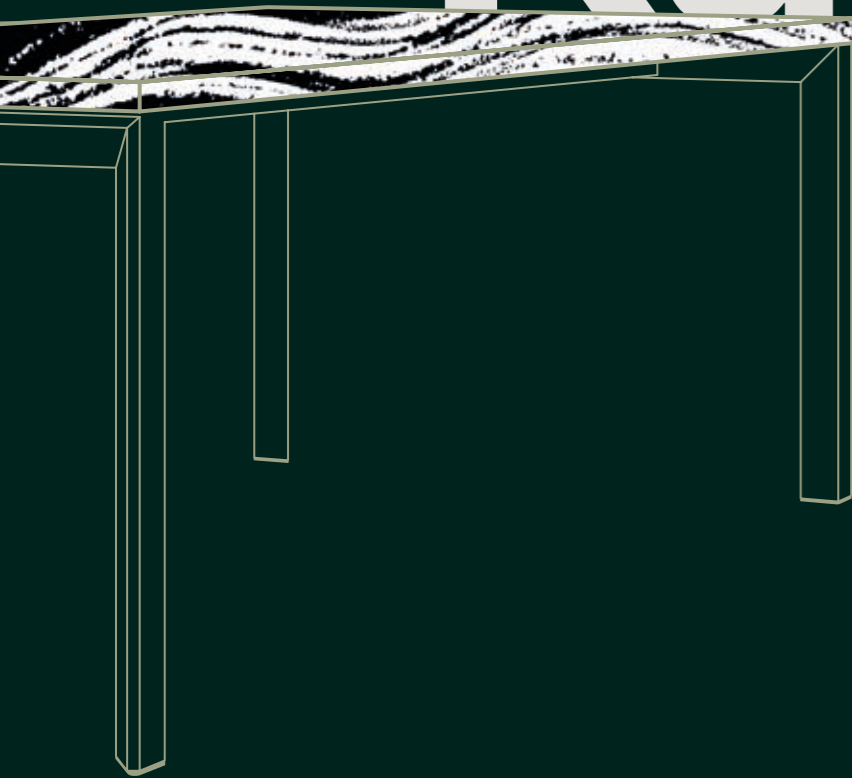

BOS
1964
BARCELONA



BOS1964
152 - 153

Management desks
Mesas de dirección

Supra
Sail
Lead
Kubo



BOS1964
154 - 155

Management desks
Mesas de dirección

Supra
Sail
Lead
Kubo









TECHNICAL INFORMATION
INFORMACIÓN TÉCNICA

Table top
Sobre

Thickness
Grosor
30

Finishes
Acabados
Wood / Madera
Lacquer / Lacado
Leather / Piel

Legs
Patas

60
Metallic / Metálico

Office tables
Mesas de despacho

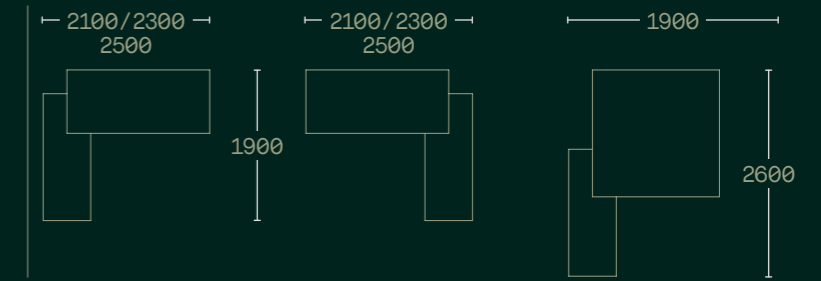

Meeting tables
Mesas de reuniones

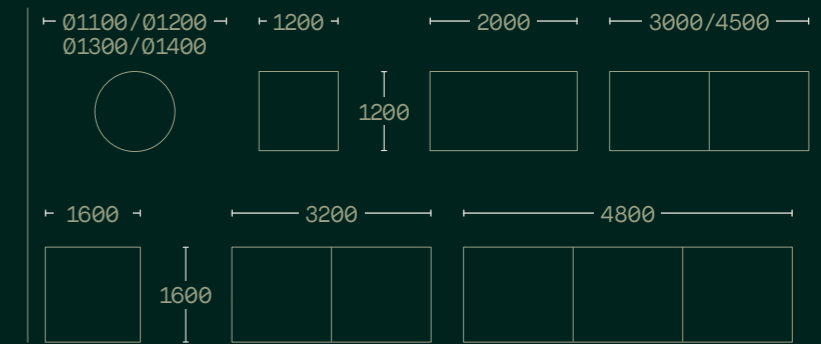

Coffee tables
Mesas de centro



Recommended bookcases: Standard (laminated)
Armarios recomendados: Standard (carcasa de melamina)

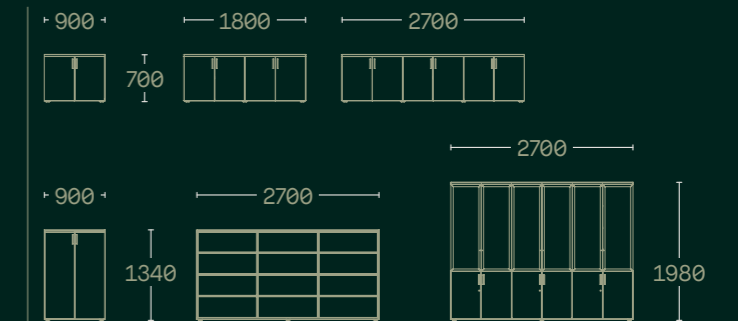

Chairs & Sofas
Sillas y sofás

CHAIRS



Musa



Vela



Rena



Diva



Dea



Diva



Dina



Vela



Rena



Lina



Musa



Aranda



Dea



Musa

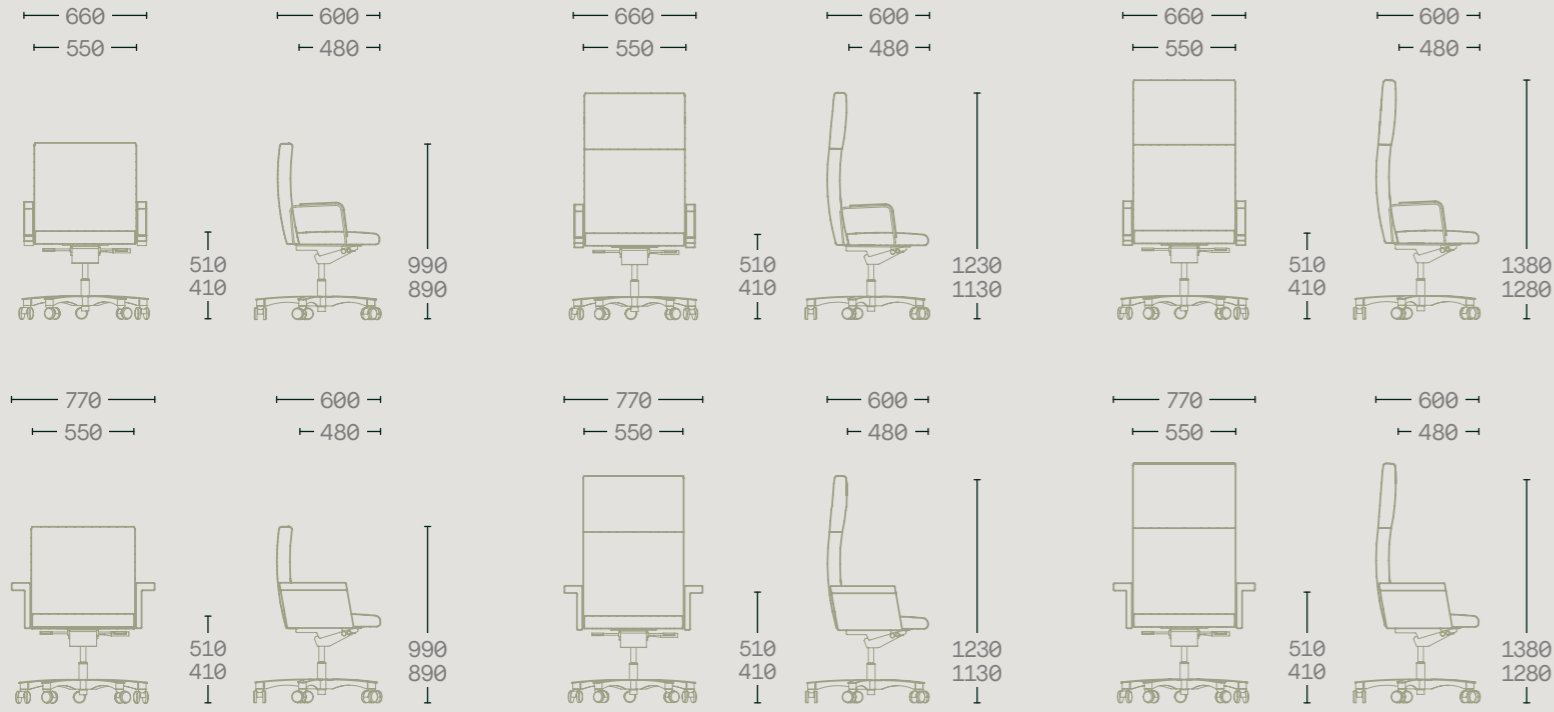

Dea

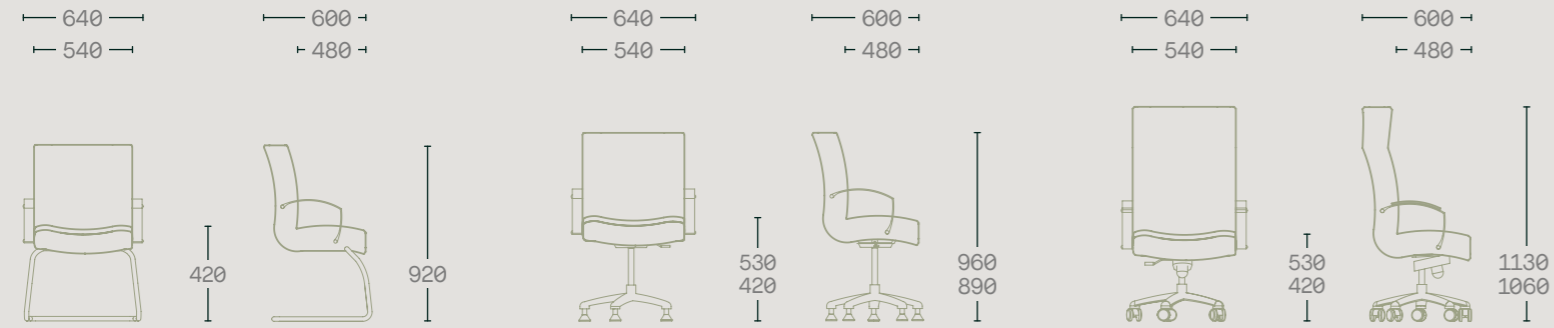

Diva

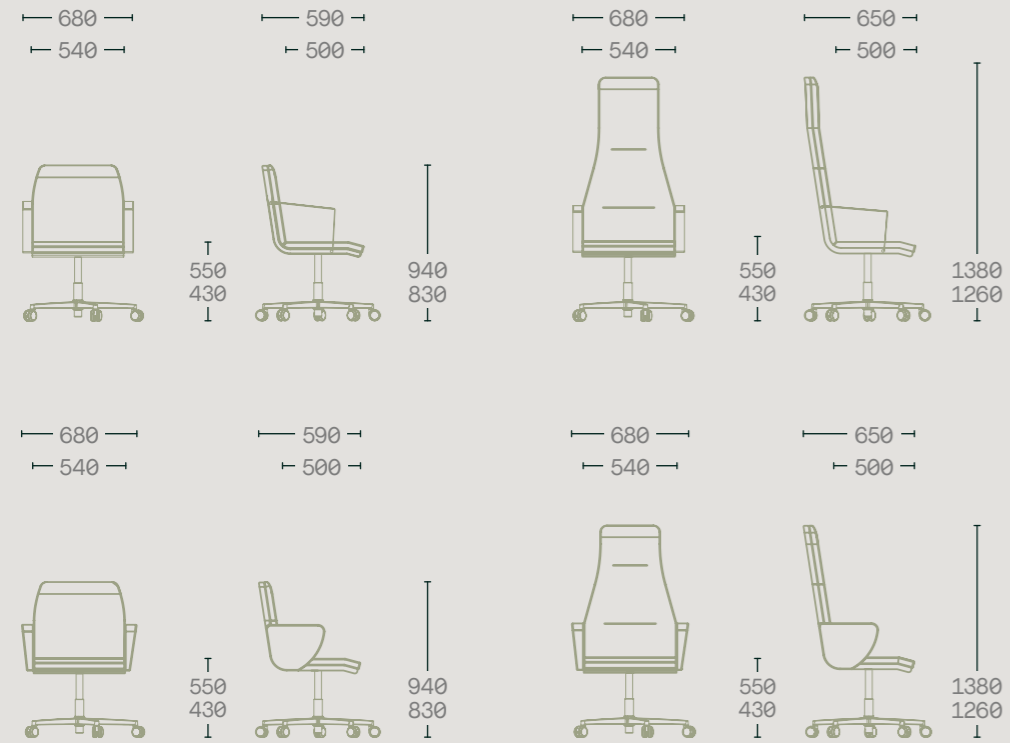

Dina

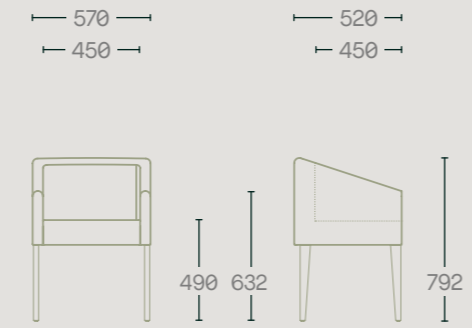

Lina

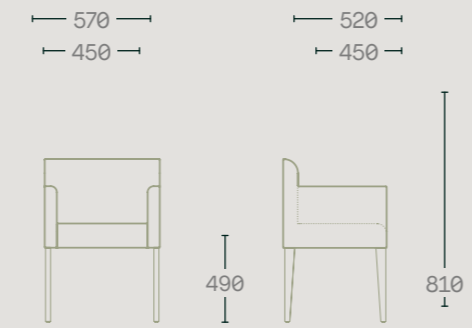

Rena

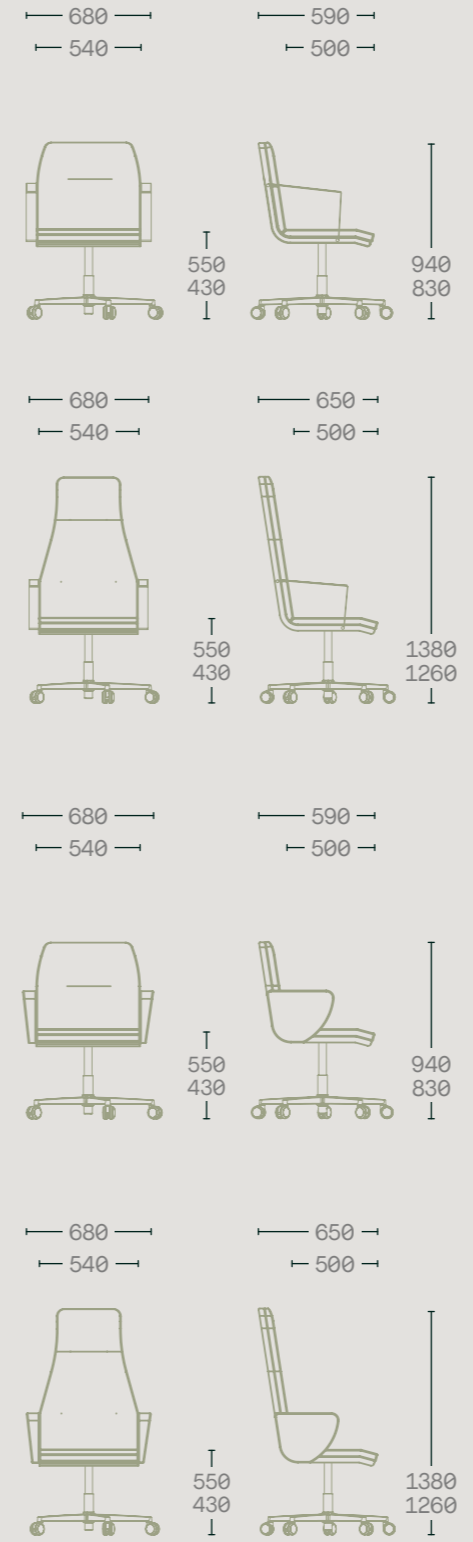

Aranda

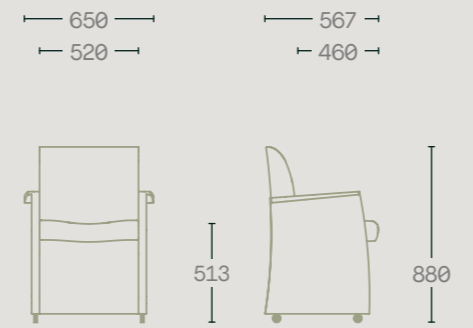

Vela

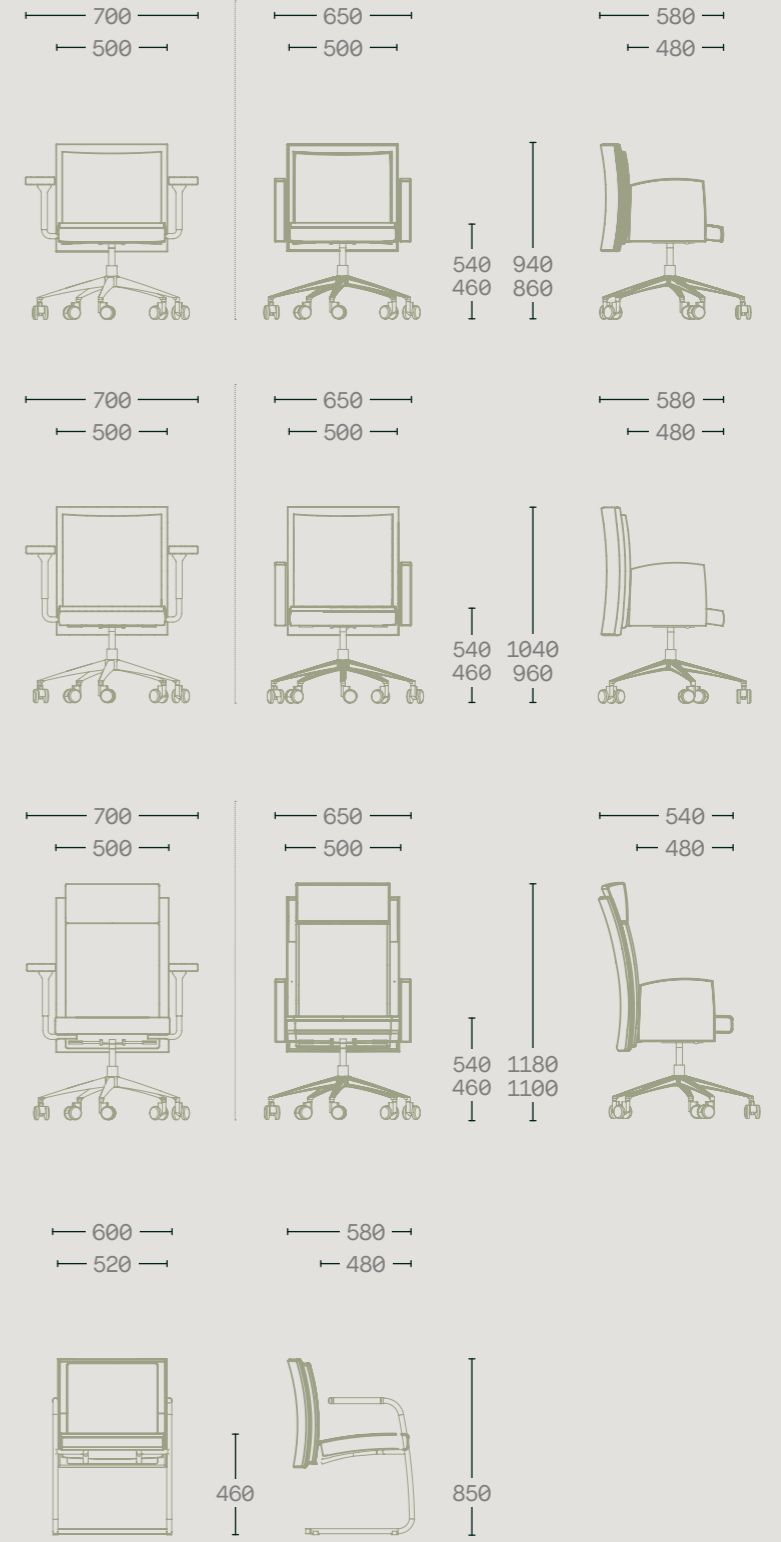

Foro



Odessa

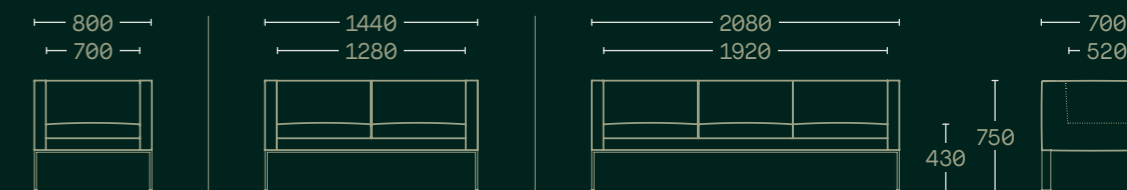
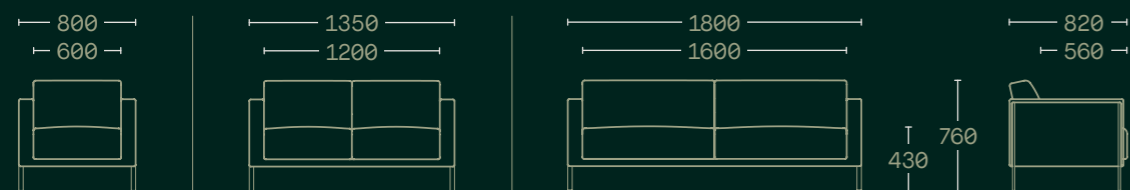

La Scala

Avocado

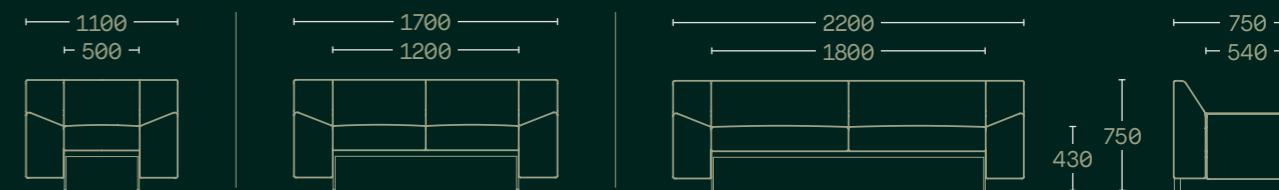
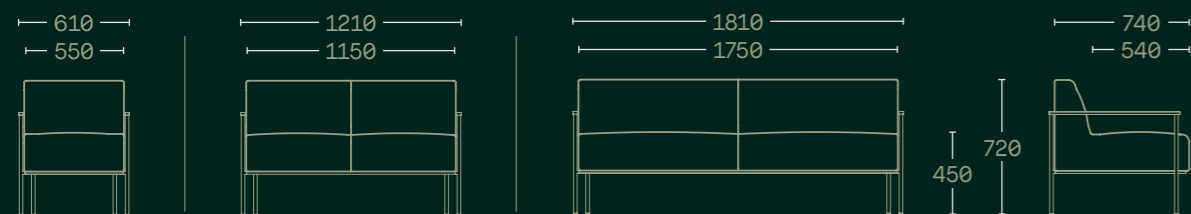

Luxury bookcases
Librerías de lujo

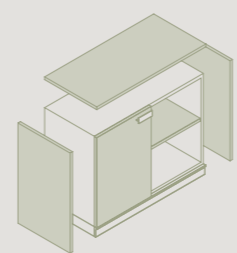

● Wood/Madera
○ Lacquered/Lacado



1840x460
h 736



2290x460
h 736



2740x460
h 736



1840x460
h 1376



2740x460
h 1376



2290x460
h 2016



2740x460
h 2016

Best recommended with collections: Touring and Diktat
Recomendaciones junto a colección: Touring y Diktat



Premium bookcases Librerías premium

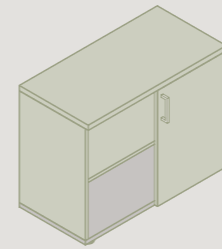

- Wood/Madera
- Laminated/Melamina

1800x450
h 700



2700x450
h 700



900x450
h 1340

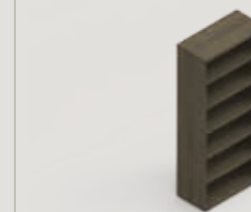

900x450
h 1980

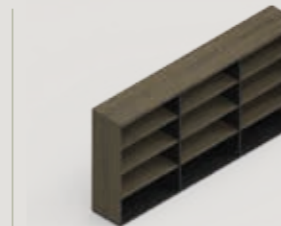

2700x450
h 1340



1800x450
h 1980

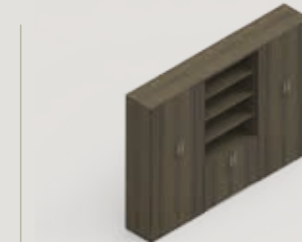

2700x450
h 1980

Recommended with: Aqua, Karan and Avant
Recomendaciones junto a: Aqua, Karan y Avant

Standard bookcases Librerías 'Standard'

Melamine options in black or white color
Opción de melamina en color negro o blanco

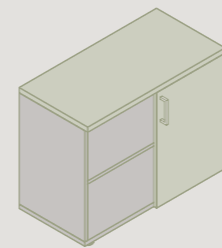

- Wood/Madera
- Laminated/Melamina

2700x450
h 700

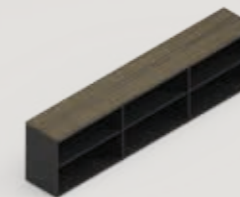

2700x450
h 1980



1800x450
h 1980



900x450
h 1340

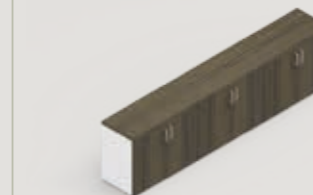

2700x450
h 700



2700x450
h 1980



1800x450
h 1980

Recommended with: Supra, Lead and Kubo
Recomendaciones junto a: Supra, Lead y Kubo

E

CH

O

L

G

T

N

O

Y

Power units



PU1
3/6 positions
Lacquer



PU4
Matt chromed



PU2
3/6 positions
Wood



PU5
3/6 positions
RAL 9006 (aluminium)
RAL 7016 (anthracite)
Inox
RAL 9005 (black)
RAL 9010 (white)



PU3
4/8 positions
RAL 9006 (aluminium)
RAL 9005 (black)



PU6
4/8 positions
RAL 9006 (aluminium)
RAL 9005 (black)



Power strips



HDMI
HDMI



RJ45 cat6
RJ45 cat6



USB
USB



DVI



HDMI
USB



HDMI



XLR
3 pins



RCA



HDMI
RJ45 cat6



USB
RJ45 cat6



RJ45 cat6

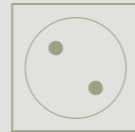

Schuko



UK socket



USB



VGA
with jack

Options for power strip positions
Opciones para posiciones de la regleta

Cable outlets



CO1
Inox



CO3
RAL 9006 (aluminium)
RAL 9010 (white)
RAL 9005 (black)

Elevation



E1

Vertical canalization



VC1



VC2



VC3



VC4

VC4

Occasional tables
Mesitas de centro

S

T

A

B



Avocado



Aqua

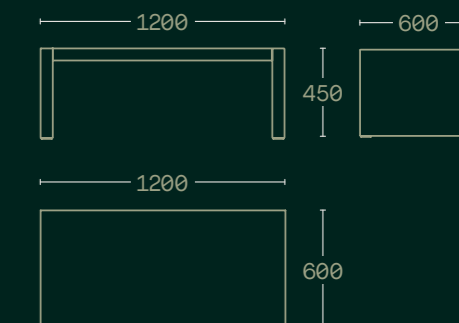
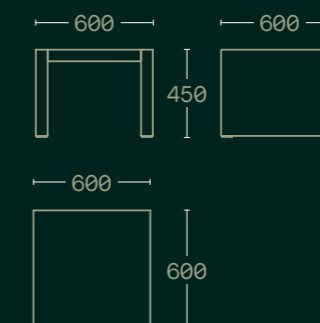
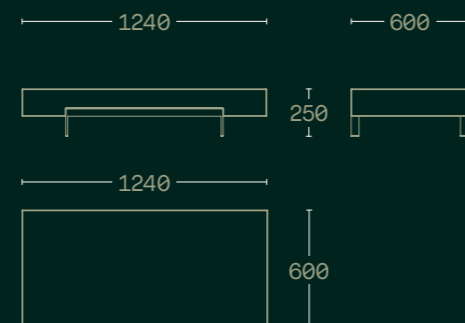
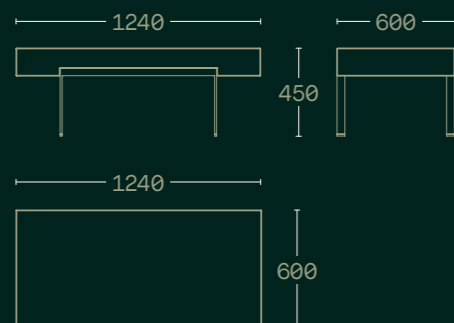
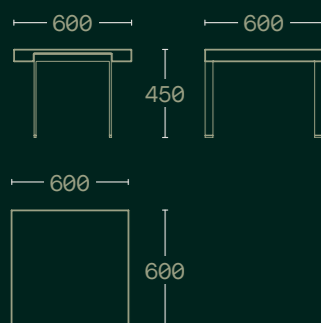

Odessa

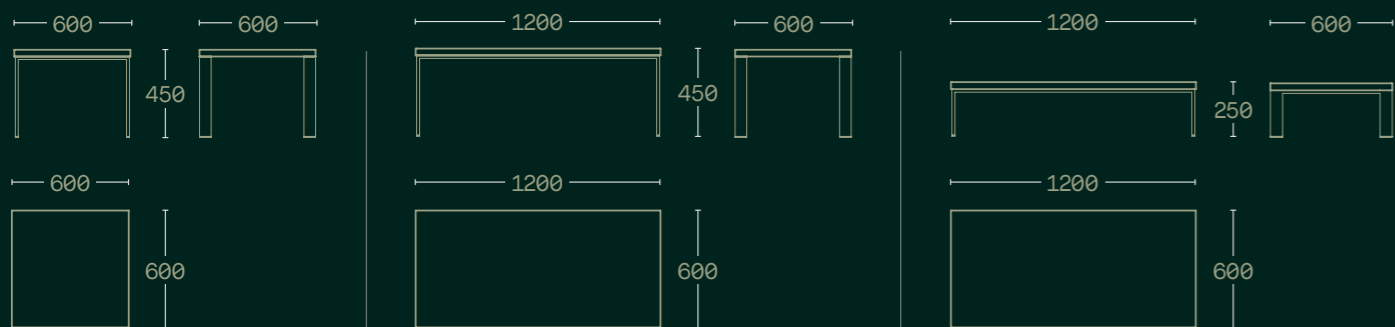

Karan

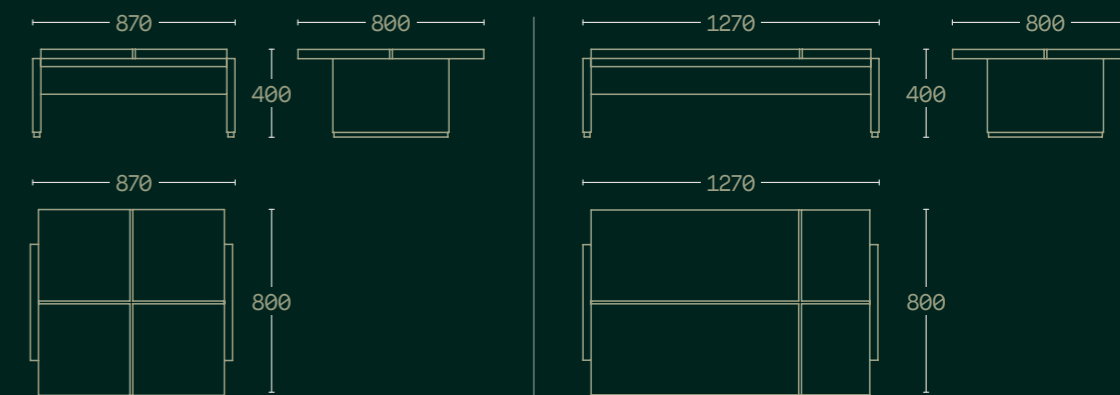
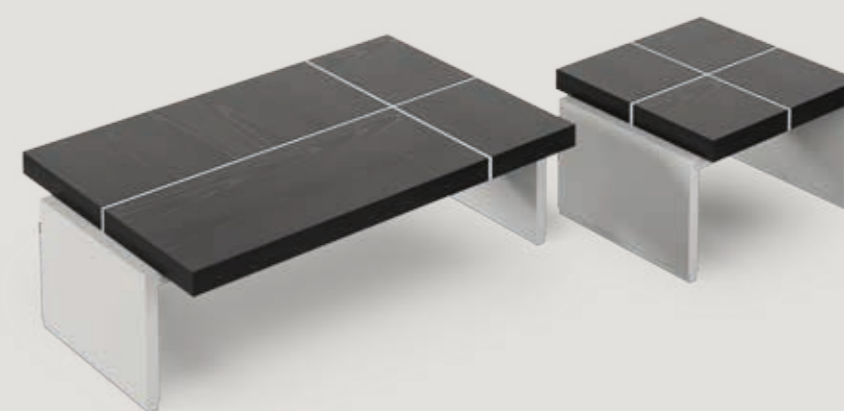

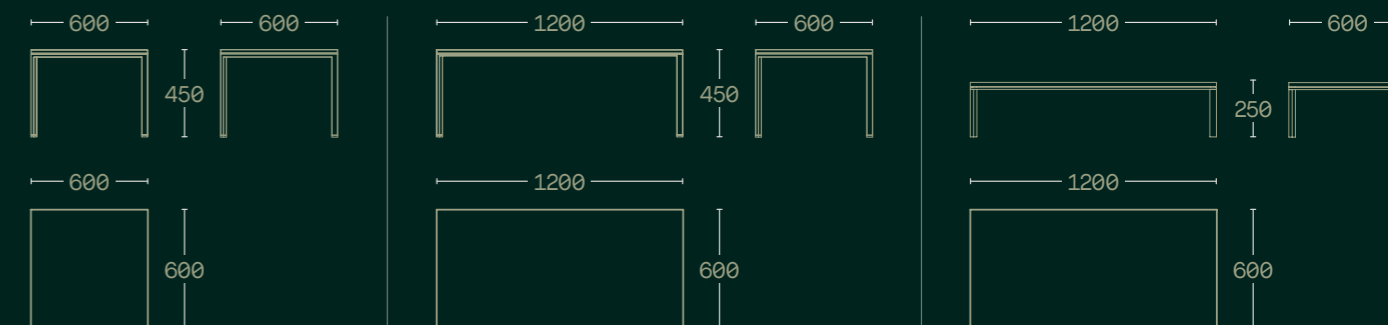
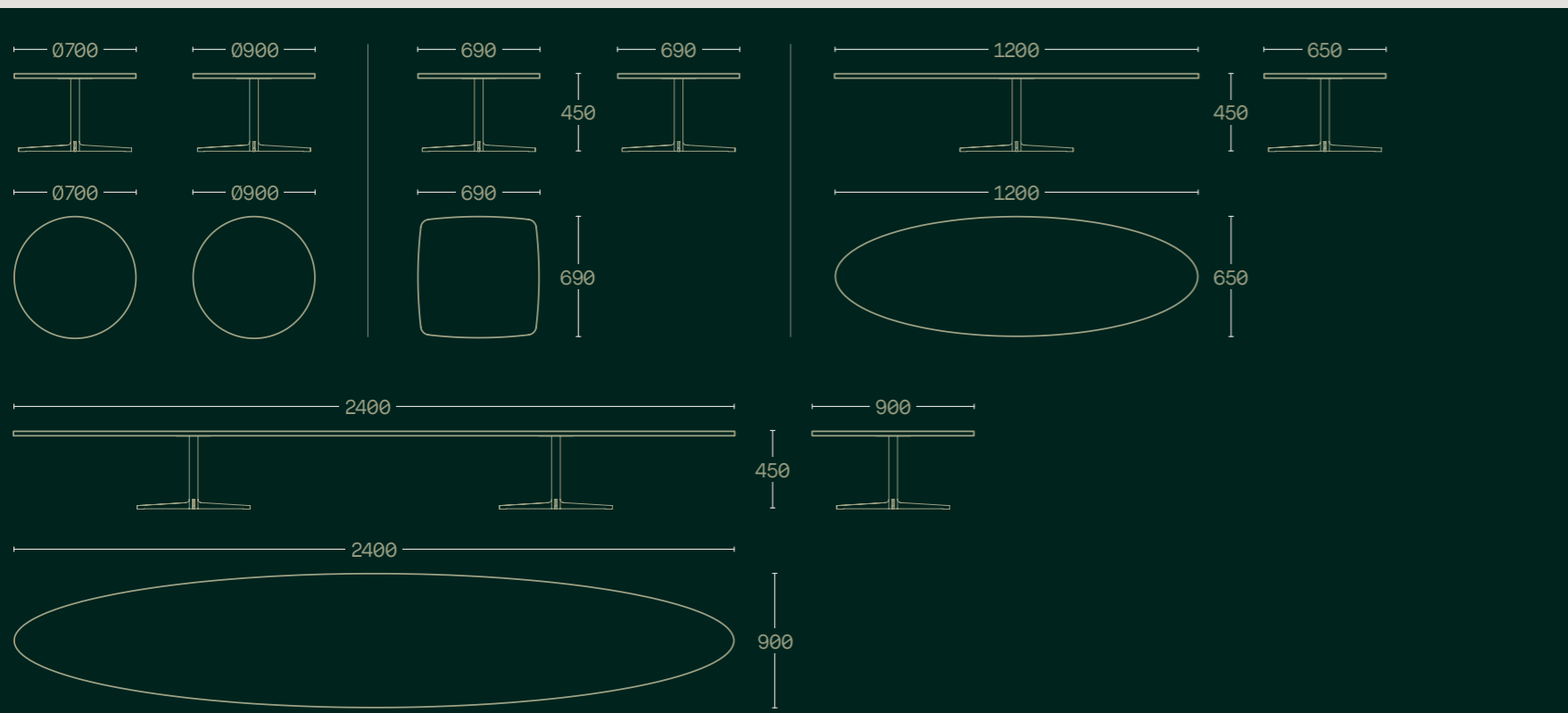

La Scala



Lead

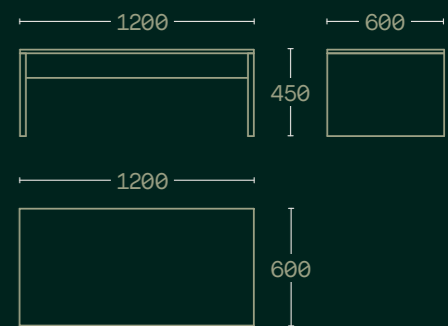
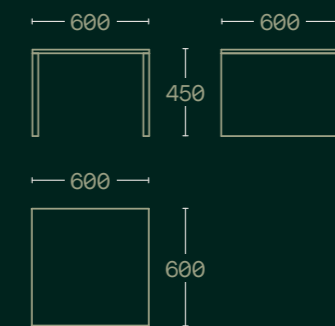
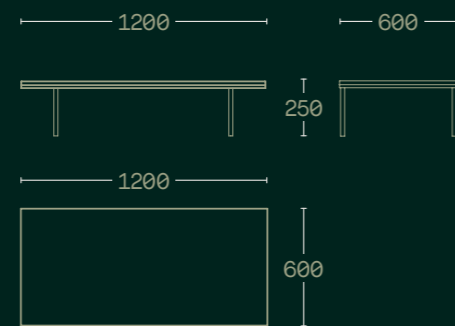
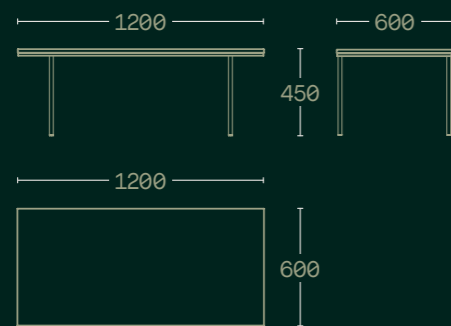
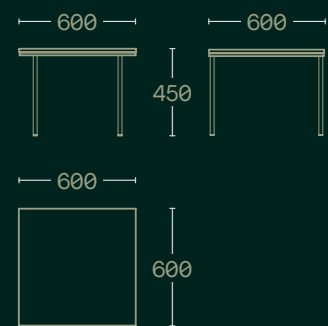
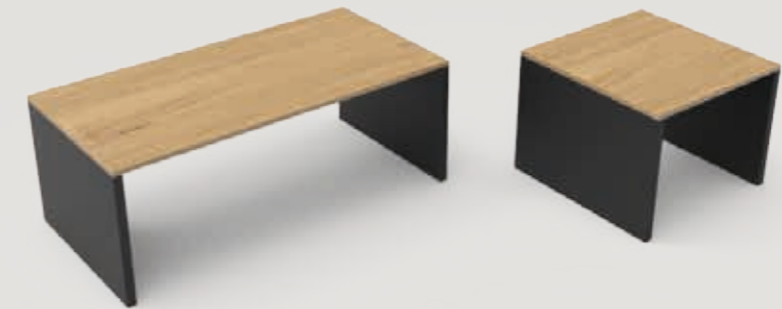

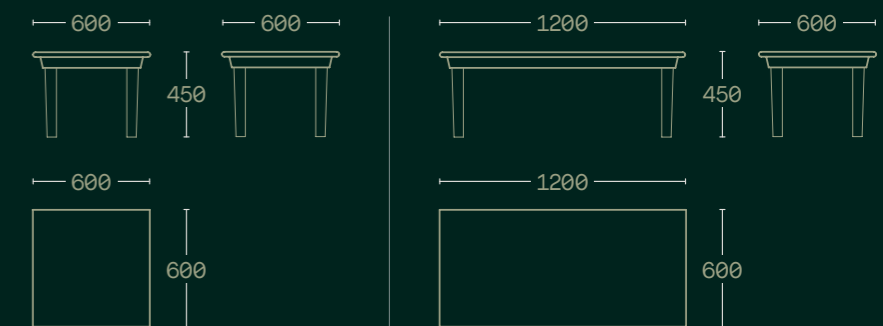
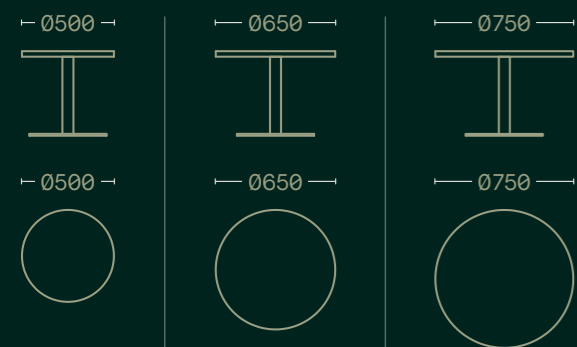

Finishes *Acabados*

BOS1964 only works with the absolute highest quality of finishes in wood as well as in upholstery with brands such as Kvadrat, Gabriel, Curtidos Gracia and Camira.

Next, you will find a selection of the available finishes which we work with. To know the whole collection, please visit the following site:

www.bos1964.com

BOS1964 utiliza en sus productos los mejores materiales en acabados de madera y en marcas de tapicería como Kvadrat, Gabriel, Curtidos Gracia y Camira.

A continuación, os presentamos una selección de nuestros acabados. Para conocer el catálogo entero visiten la siguiente dirección:

www.bos1964.com

Natural wood
Madera natural

The natural wood comes standard with matt finish but is also available with high gloss finish.

De serie, la madera natural tiene un acabado mate; pero también está disponible en alto brillo.

Lacquer & paint
Laca & pintura

These RAL colors are available for lacquer when applied on MDF and for paint when applied on metal parts. The lacquered colors are available with matt or piano lacquer finish (different RAL colors can be used upon request).

Los colores RAL, cuando son aplicados en madera son lacas y cuando son aplicados en superficies metálicas, son pinturas. Las lacas, están disponibles en mate o laca piano. Bajo petición, se puede aplicar cualquier color.

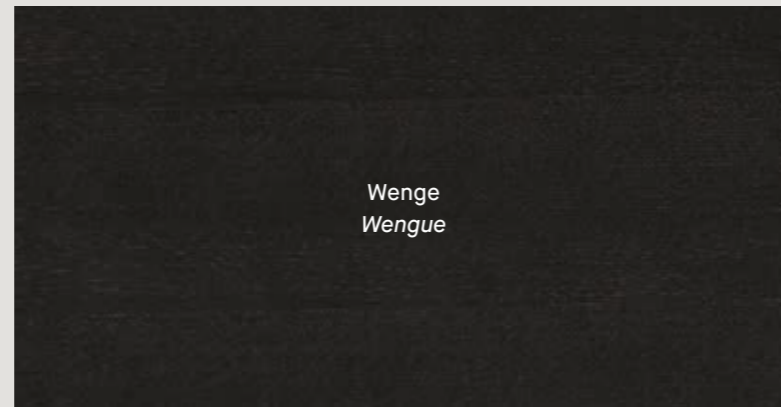
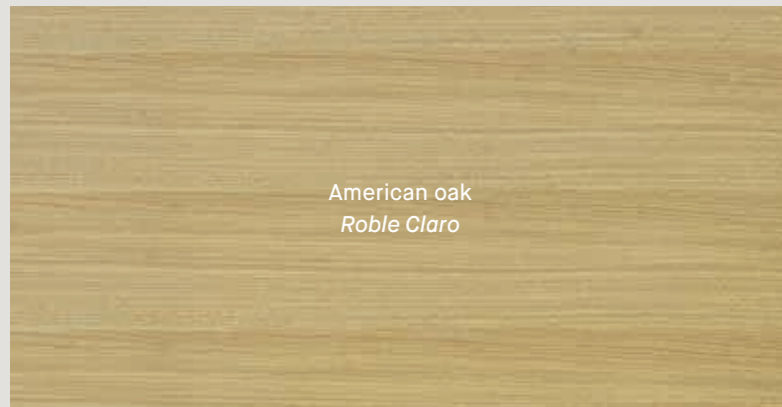
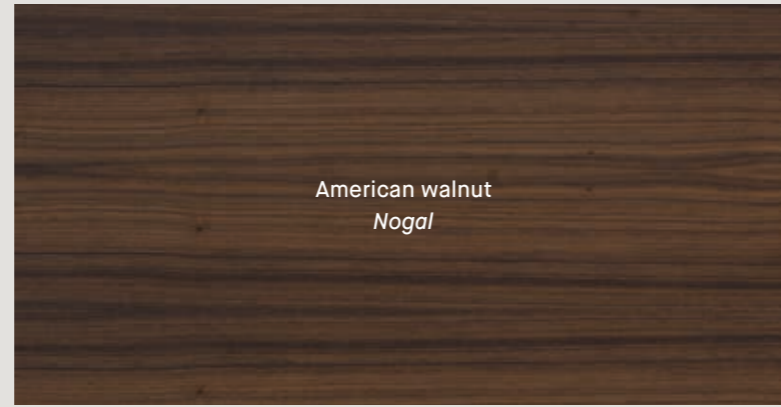
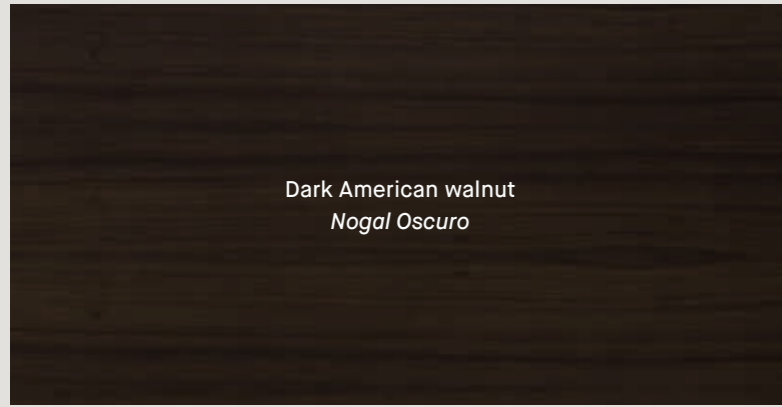
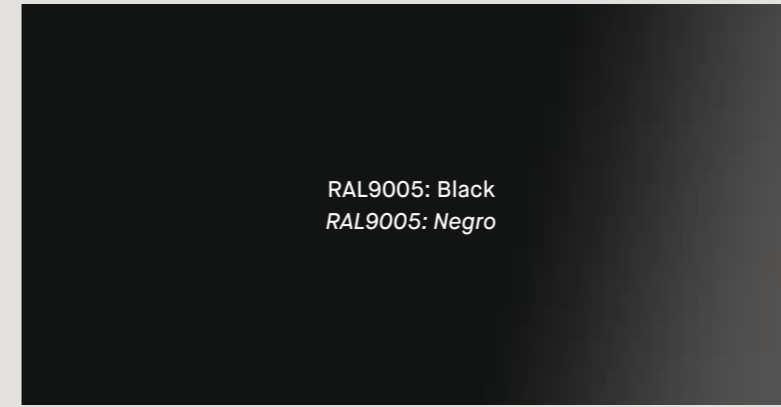
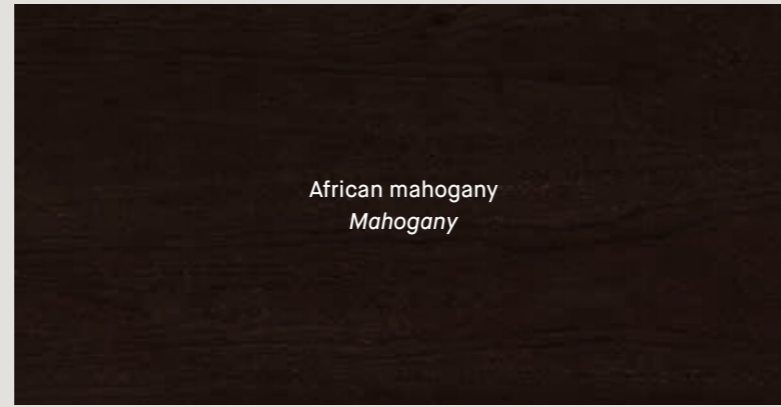
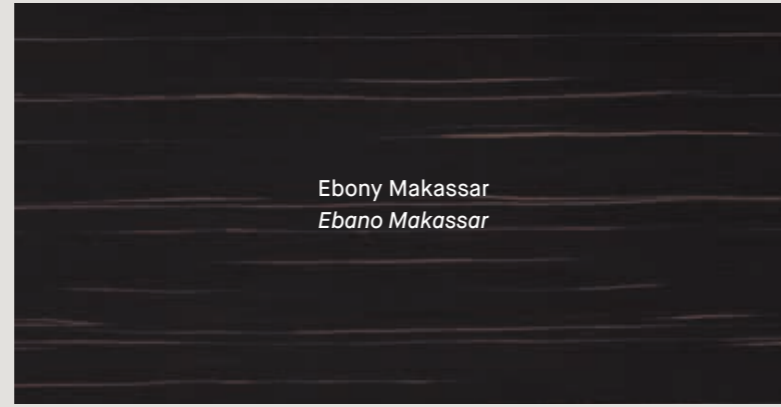

Leather
Piel

Fabric
Tela

Serie 900 Fusion by Curtidos Gracia
Serie 900 Fusion de Curtidos Gracia



Blazer collection by Camira
Colección Blazer de Camira



Main Line Flax collection by Camira
Colección Main Line Flax de Camira



Thanks for trusting us

Gracias por confiar en nosotros

EUROPE

AkzoNobel (Spain)
Alior Bank (Poland)
Allianz (Spain)
Alpha TV (Greece)
American Embassy (Belgium)
Bank of London (Spain)
Barcelona Airport (Spain)
Barcelona University (Spain)
Bayer (Spain)
BBL (Belgium)
BNP Paribas (France)
Danone (Spain)
Fitch Ratings (Spain)
France Telecom (France)
GAP (Greece)
Gestamp (Spain)
Gonvarri (Spain)
Good-year (Spain)
Gulf Agency Co. (Cyprus)
Heineken (Poland)
Henkel (Portugal)
Hospital de Barcelona (Spain)
Huawei (Spain)
ICBC, Industrial and Commercial Bank of China (Luxembourg)
Ing Real Estate (Poland)
Kempinski Hotels (Switzerland)
Kone (Spain)
MCLaren Mercedes Benz (UK)
Mitsubishi (Portugal)
NEA ODOS (Greece)
Porsche (France)
Procter&Gamble (Spain)
Renault (France)
Repsol (Spain)
Rolex (Germany)
Santander Private Banking (Italy, Portugal, Spain, UK)
Saudi Embassy (Belgium)
Trafigura (Switzerland)

MIDDLE EAST

Abu Dhabi Sports Council (UAE)
ADSIC Abu Dhabi Systems & Informations Center (UAE)
Al Habib (Oman)
Al Jahra Hospital (Kuwait)
Al Jalila Foundation (UAE)
Al Rayyan (Qatar)
ANB Bank (KSA)
Arab News Channel (Bahrain)
Ashghal (Qatar)
Bank Al Bilad (KSA)
Civil Aviation Authority (Qatar)
Crown Prince Court (UAE)
Dubai Airport (UAE)
Dusor (KSA)
Ministry of Economy (KSA)
Ministry of Economy (Qatar)
First Gulf Bank (UAE)
Ministry of Foreign Affairs (KSA)
Global Investment Group (UAE)
Gulf Corporation for Technology (Bahrain)
Huawei (Qatar)
Ministry of Interior (KSA)
K.O.C. Kuwait oil company (Kuwait)
King Saud University (KSA)
Kings College Hospital (UAE)
Magnificent Media (UAE)
Mashroat (KSA)
Ministry of Communications (KSA)
Mohsin haider darwish (Oman)
National Bank (UAE)
Nizwa Bank (Oman)
Ocean Fair Company (UAE)
Procter & Gamble (UAE)
Qassim University (KSA)
Qatar Foundation (Qatar)
Qatargas (Qatar)
Royal Jet (UAE)
RTA, Roads & Transport Authority (UAE)
SAMA, Saudi Arabian Monetary Agency (KSA)
SAR, Saudi Arabian Railways (KSA)
SCA Stock Exchange (UAE)
Schlumberger (Kuwait)
SEC, Saudi Electricity Company (KSA)
Ministry of Survey and Land Registration (Bahrain)
The Land (KSA)
Yasref (KSA)

CIS

Apostol (Russia)
Boeing (Ukraine)
British American Tobacco (Ukraine)
Compass (Kazakhstan)
Egvinot (Russia)
EPAM, Egorov Puginsky Afanasiev & Partners (Russia)
ERG Group (Kazakhstan)
FTI Consulting (Russia)
Kazchrome (Kazakhstan)
Kazkommertsbank (Kazakhstan)
KazTransOil (Kazakhstan)
Marie Claire (Russia)
Megafon (Russia)
Mondelez (Russia)
Moscow City Council (Russia)
Russian Agricultural Bank (Russia)
SAP (Russia)
Sberbank (Kazakhstan)
Severstal (Russia)
TAU Development (Kazakhstan)
Teva (Russia)
Total (Kazakhstan)
Visor (Kazakhstan)
VTB bank (Russia)
White&Case (Kazakhstan)

AFRICA

African Bank (Egypt)
Barclays (Egypt)
Municipality of Cabinda (Angola)
Carlyle (Egypt)
CIB Bank (Egypt)
HSBC (Egypt)
Imperial Investment (Egypt)
Intercontinental (Egypt)
Limitless (Egypt)
Mantrac (Egypt)
Mobinil (Egypt)
Morait's Letao (Angola)
Noor (Egypt)
Power Investment Company (Mozambique)
Rama (Kenya)

BOS1964 provides innovative, client focused design furniture solutions for the world community of executive offices and boardrooms. One of our main objectives is to find a perfect balance between classic and modern designs that ensures durability as well as icons in terms of handcraft and innovation. This is achieved thanks to our dynamic multicultural team which, by combining top-notch technology and strong expertise in traditional manufacturing.

BOS1964 ofrece soluciones innovadoras y de diseño dirigidas a clientes de ámbito mundial interesados en mesas de despacho, mesas de reuniones y sillas de dirección. Estas soluciones vienen avaladas por una experiencia dilatada en los años que ha estudiado detenidamente la integración de estos productos en las distintas áreas de dirección adecuándose perfectamente a cualquier decoración y a cualquier ambiente.