

kendo

2023

We make designs to live them

Design furniture is the fundamental driving force behind all kinds of original, unique and elegant spaces. This indispensable piece for any room configuration often arises from concepts and design ideas of the most notable and experienced designers, in moments where the concept touches with reality to achieve a new creation.

In this new catalogue we want to contribute our particular way of understanding furniture, providing all kinds of facilities and possibilities of adaptation so that it is not a watertight compartment, but a window where we can exchange concepts and ideas that help us to learn and undertake once again this adventure that we have been enjoying for more than 20 years.



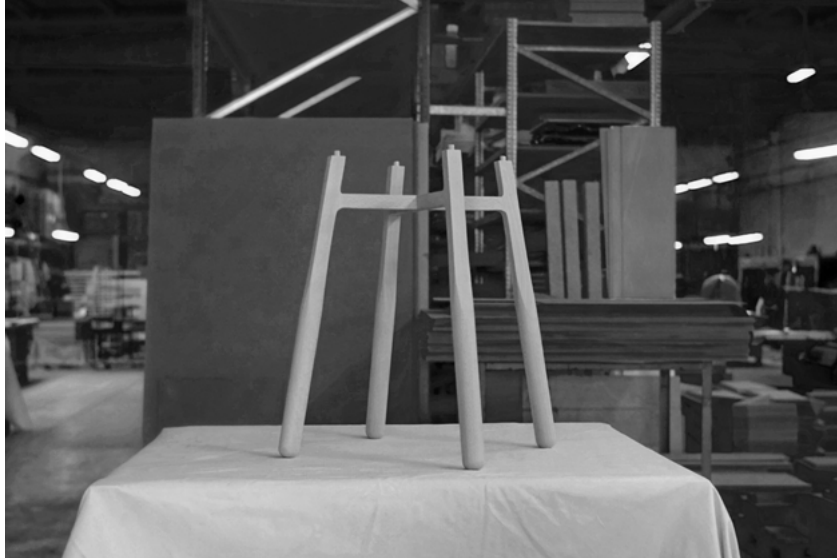

Our story began in Valencia (Spain) in 2000, with the illusion and desire to make unique, handcrafted and timeless furniture. Little by little, a company dedicated to the manufacture of designer furniture has been formed, and since then we have been accompanied by artisan techniques in all our designs and products.

Each of our pieces is made with the intention of awakening the most intrinsic sensations of the user and achieving optimum functionality within a specific space. For this reason, we take great care in everything we do, the materials, how we work them, each raw material, each process and each detail.

We use natural materials, sustainable from production to end of life, handmade, and we use them to create honest and sensitive pieces that allow us to help tell a story. We champion long lasting contemporary furniture to accompany us throughout our lives.

That is why we have ISO 9001 and 14001 accreditations that certify our sustainable production as well as FSC and PEFC accreditations that endorse our concern for the environment. We know the importance of combining quality with care and respect.

We are passionate about the way people and spaces connect through design. We are totally customer-oriented, always listening to their needs and trying to live up to them, we like to create solid and lasting relationships with all of them, and it is thanks to them that today, more than 20 years after our creation, we continue to move forward with the same enthusiasm as we did then.

Our reason for being

We work every day to create unique and lasting designs that will become design classics, by deeply developing their qualities in unique spaces where we give ourselves completely to the personalisation and refinement of our products.

To achieve our goals, we are always focused on giving free rein to all the concepts of our designers so that our products are not only formal, stylish and elegant designs but also provide that point of freedom, originality and personality of those who offer us their best ideas.

At Kendo we enjoy our relationships with all the people around us, whether they are suppliers, designers, sales people or interior design studios of the highest level. We know that our role is to cultivate and strengthen these relationships so that we can offer the user an unrivalled experience of design, elegance and versatility.

That is why our collections perfectly represent our concerns and tastes. At heart, they express all that desire to make originality and inspiration the most tangible mark of our activity, the desire to transform furniture design into something more.



We believe that great designs are meant to be experienced, which is why we have developed a website that allows you to view many of our projects all over the world. We collaborate on projects that are fully customised in terms of materials, measurements and finishes. We create products with high quality materials that manage to last for generations. Discover the collections designed to meet the most demanding requirements of contract and residential projects.

Design and talent

The success of Kendo's design comes from the hand of prestigious international designers. We are very proud to have all of them and their timeless designs that perfectly reflect our philosophy, as they share the same passion for workmanship, fine materials and timeless creations. Together we create designs conceived to last over time. Each piece is tested to meet the highest standards of strength, quality and sustainability.



Miguel Milá



OrtegaGujjarro



Yembarastudio



Discoh Design

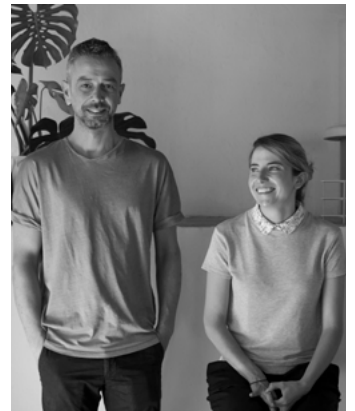

PerezOchando



Mario Ruiz



Francesc Rifé



Antoni Arola

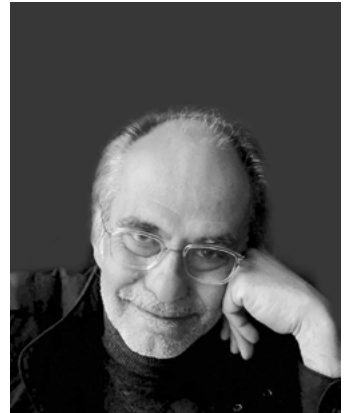

Gabriel Teixidó



Luis Arrivillaga



Vicente Gallega



Héctor Diego



Serafín Redondo

Find your pieces in less than 10 seconds

Mac Users: We recommend using **Google Chrome** to take advantage of the interactive features. Windows users will be able to open it in any PDF viewer.



Move quickly through our catalogue thanks to our interactive areas, which will allow you to move easily and without waiting to the products or collections you want.

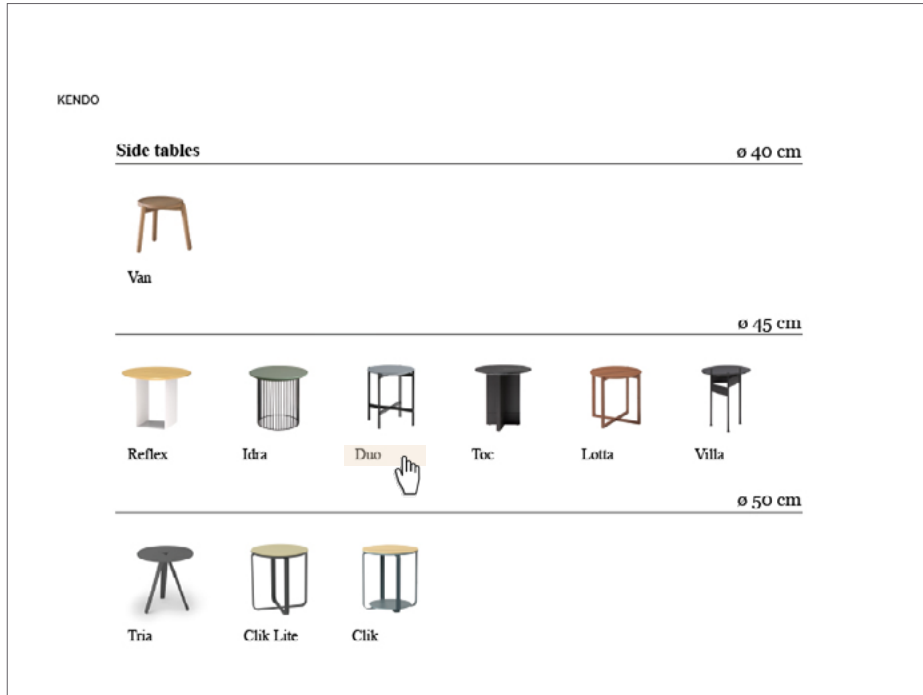

Discover our index by type of product, which will allow you to find the designs you are looking for quickly by classifying them by size.

Collections



Van - Pg 404



Lotta - Pg 270



Mika - Pg 292



Tria - Pg 482



Villa - Pg 328



Rita - Pg 110



Rita Lite - Pg 152



Toc - Pg 38



Yohsi - Pg 352



Duo - Pg 54



Reflex - Pg 390



Temps - Pg 378



Trazo - Pg 418



Exo - Pg 186



Clik - Pg 456



Exo Round - Pg 228



Idra - Pg 74



Clik Lite - Pg 466



Rita - Pg 144



Exo - Pg 218



Rita Lite - Pg 164



Grey - Pg 446



Axil - Pg 476



Naruk - Pg 244



Rita - Pg 128



Exo - Pg 210



Beco - Pg 172



Naruk - Pg 254



Rita - Pg 136



Porciones - Pg 22



Naruk - Pg 262



Rita - Pg 110



Rita Lite - Pg 152



Rita Lite - Pg 152



Rita - Pg 110



Temps - Pg 378



María - Pg 438



Trazo - Pg 418



Mika - Pg 292



Exo - Pg 186



Lotta - Pg 270



Villa - Pg 328



Van - Pg 404



Duo - Pg 54



Ant - Pg 306



Ant Lite - Pg 318



Idra - Pg 74



Exo Round - Pg 228



Reflex - Pg 390



Clik - Pg 456



Clik Lite - Pg 466



Yohsi - Pg 352



Toc - Pg 38



Vera - Pg 428



Plat - Pg 342



Yohsi Elíptica - Pg 370



Exo - Pg 204



Totem - Pg 94

Side tables

ø 40 cm



Van

ø 45 cm



Reflex



Idra



Duo



Toc



Lotta



Villa

ø 50 cm



Tria



Clik Lite



Clik

ø 55 cm



Reflex



Idra



Yohsi



Toc



Duo



Exo Round



Villa



Lotta

ø 60 cm



Van

Coffe tables

ø 65 cm



Toc

ø 70 cm



Reflex



Idra



Yohsi



Mika



Duo



Klik Lite



Exo Round



Villa



Klik



Lotta

ø 80 cm



Van

ø 100 cm



Reflex



Yohsi

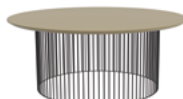

Idra



Duo



Villa



Exo Round



Klik Lite



Klik



Lotta



Ant Lite

Ø 120 cm



Yohsi



Duo



Exo Round



Lotta



Ant Lite



Ant*

* 128 / 148 cm

Side tables

40 x 40 cm



Trazo

60 x 60 cm



Trazo



Exo



Rita

Coffee tables

70 x 70 cm



Rita Lite



Rita



Temps

100 x 100 cm



Exo



Plat



Porciones*



Rita Lite

* 4 modules



Rita



Vera

120 x 120 cm



Plat



Rita Lite



Rita



Vera

105 x 70 cm



María

120 x 45 cm



Mika



Naruk

120 x 60 cm



Exo



Rita Lite



Temps



Rita

160 x 70 cm



Plat

120 x 90 cm



María

140 x 60 cm



Yohsi elíptica

180 x 60 cm



Yohsi elíptica

Desks



Beco



Rita



Naruk

Consoles



Naruk



Exo



Rita



Axil



Grey

TV furniture



Exo



Totem

Auxiliary complements



Exo



Exo



Rita Lite



Rita

PORCIONES

Variable and flexible

Miguel Milá



Miguel Milá, a great reference in Spanish industrial design, has collaborated with us in the re-edition of Porciones. A table made up of four triangular pieces, which can be used together

or separately to achieve multiple compositions. Noble materials, craftsmanship and detail in each process, is the summary of his impeccable timeless design that marks an unequalled trajectory.





The option of creating customised sets with noble materials makes it possible to easily adapt to the needs of any environment, whether in the home or in contract projects.





It is a variable and flexible table that allows for a variety of compositions and different uses.

Coffee table composed of two modules in Taupe lacquer finish together with an auxiliary complement composed of three modules in ash oak finish.





COMBINABILITY, FUNCTIONALITY AND SIMPLICITY

It is a timeless design, endowed with excellent proportions that create unique and personal spaces thanks to the multiple combinations of its pieces and its different finishes.

On these pages, different combinations of the Porciones table, in different finishes in lacquer, natural oak and ash oak.

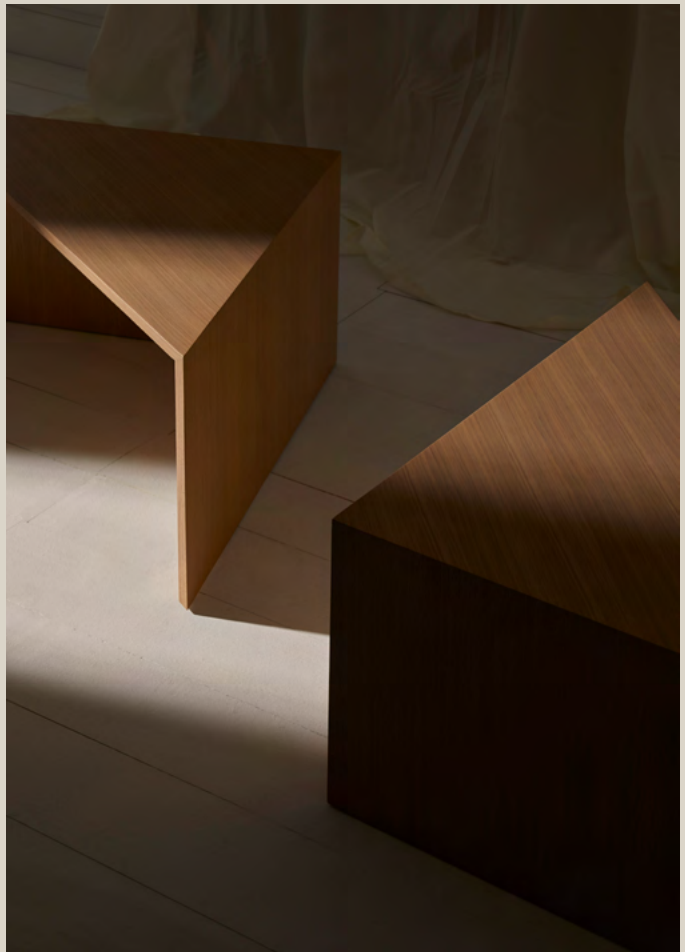





*On these pages, different combinations of the
Portions table, natural oak finish.*

● Natural oak



Porciones is a piece created entirely through a handcrafted process that takes into account the quality of the materials and finishes.





On this page, coffee table composed of two modules in ash oak finish next to a coffee table composed of four modules in graphite finish.





● Ash oak



● Taupe

Finishes

Laca, roble
Lacquer, oak

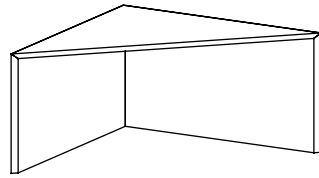

Blanco
White



Piedra
Stone
RAL 7044



Arena
Sand
NCS S2005-Y20R



Visión
Taupe
NCS S4005-Y20R



Grafito
Graphite
RAL 7022



Pizarra
Slate
NCS S8500-N



Negro
Black



Niebla
Fog
NCS S5005-B20G



Océano
Ocean
NCS S7010 B10G



Menta
Mint
NCS S3010 G20Y



Oliva
Olive
NCS S6010 G10Y



Bosque
Forest
NCS S7010 B90G



Teja
Tile
NCS S5030 Y90R



Roble natural
Natural oak



Roble claro
Light oak



Roble teñido ceniza
Ash stained oak



Roble teñido tostado
Toasted stained oak



Roble teñido wengue
Wengue stained oak



Roble negro
Black oak

Technical specifications

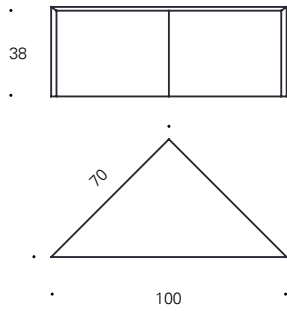

POR-07 100x70x38 cm

Laca
Lacquer

Roble
Oak

Ejemplo de composiciones
Sample compositions

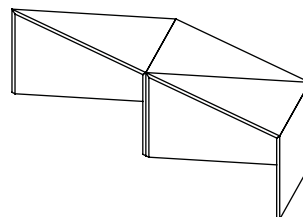
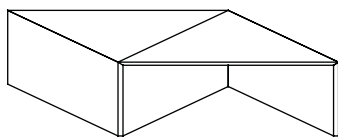
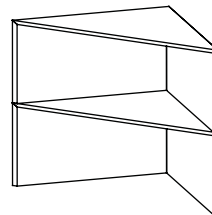
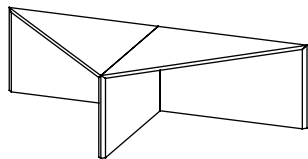
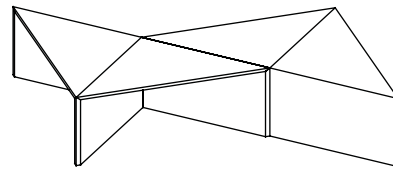
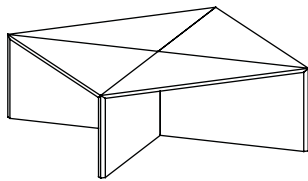

TOC

Personality

Francesc Rifé



The Toc collection bears the hallmark of Francesc Rifé. It stands out for its minimalist influence, respect for craftsmanship and a geometric proportion that defines its identity. They are small tables with their own personality that bring the necessary warmth to any space.





On these pages, Toc base in ash oak.



*On these pages, Toc combination,
different finishes in lacquer and marble.*



COMBINABILITY

Toc was created to create a visual play in space. A unique piece that stands out for its T-shaped base, with its micro-textured slate-coloured bottom. The designs are available in three sizes, and all three work well together in a central space, as well as on their own in any corner of the room.



Elegance and
at its p



d adaptability
purest





*Sa Font Seca residential development, Mallorca (Spain).
Project by Negre.*





The collection is personality and warmth, which is why it adapts to all types of environments. It includes the typology of bedside tables offering a unique character combined with maximum functionality.

The option of creating personalised sets with noble materials makes it easy to adapt to the needs of any environment, whether in the home or in contract projects.

*Francesc Rifé nightstand with ash oak finish
from the Toc collection.*



Toc is synonymous with originality and elegance. Its combination of planes in its structure as well as its circular top gives it a formal and versatile style that allows it to adapt to a wide variety of spaces and rooms, always contributing its handcrafted essence.

Available in a wide variety of finishes and sizes, the Toc collection allows total customisation to suit the needs of the user and offers alternatives and possibilities to make your environment a space of integral design.



On this page, Toc in different sizes and finishes.

Toc Tables



Top and structure sand



Black marble top and light oak structure



White marble top and graphite structure



Top and structure forest green



Top and structure in slate



Top and structure in natural oak



Top in white marble and taupe structure



Top and structure in ocean



Black marble top and ash structure

Finishes

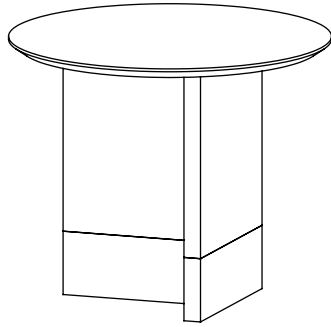

Tapa - Laca, roble, mármol negro o blanco
 Top - Lacquer, oak, black or white marble

Estructura - Laca, roble
 Structure - Lacquer, oak

Base - Laca microtexturada pizarra
 Base - Slate micro-textured lacquer



Blanco
White



Piedra
Stone

RAL 7044



Arena
Sand

NCS S2005-Y20R



Visión
Taupe

NCS S4005-Y20R



Grafito
Graphite

RAL 7022



Pizarra
Slate

NCS S8500-N



Negro
Black



Niebla
Fog

NCS S5005-B20G



Océano
Ocean

NCS S7010 B10G



Menta
Mint

NCS S3010 G20Y



Oliva
Olive

NCS S6010 G10Y



Bosque
Forest

NCS S7010 B90G



Teja
Tile

NCS S5030 Y90R



Roble natural
Natural oak



Roble claro
Light oak



Roble teñido ceniza
Ash stained oak



Roble teñido tostado
Toasted stained oak



Roble teñido wengue
Wengue stained oak



Roble negro
Black oak



Mármol blanco
White marble



Mármol negro
Black marble

Technical specifications

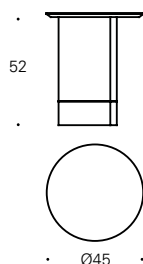

TOC-45

Ø45x52 cm

Tapa y estructura laca / Base laca microtexturada pizarra
Lacquer top and structure / Slate micro-textured lacquer base

Tapa y estructura roble / Base laca microtexturada pizarra
Oak top and structure / Slate micro-textured lacquer base

Tapa mármol negro o blanco / Estructura laca / Base laca microtexturada pizarra
Black or white marble top / Lacquer structure / Slate micro-textured lacquer base

Tapa mármol negro o blanco / Estructura roble / Base laca microtexturada pizarra
Black or white marble top / Oak structure / Slate micro-textured lacquer base

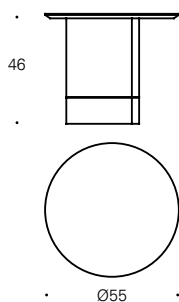

TOC-54

Ø55x46 cm

Tapa y estructura laca / Base laca microtexturada pizarra
Lacquer top and structure / Slate micro-textured lacquer base

Tapa y estructura roble / Base laca microtexturada pizarra
Oak top and structure / Slate micro-textured lacquer base

Tapa mármol negro o blanco / Estructura laca / Base laca microtexturada pizarra
Black or white marble top / Lacquer structure / Slate micro-textured lacquer base

Tapa mármol negro o blanco / Estructura roble / Base laca microtexturada pizarra
Black or white marble top / Oak structure / Slate micro-textured lacquer base

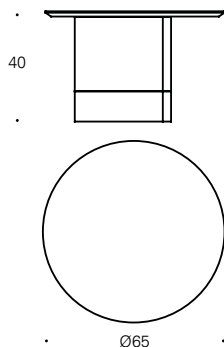

TOC-64

Ø65x40 cm

Tapa y estructura laca / Base laca microtexturada pizarra
Lacquer top and structure / Slate micro-textured lacquer base

Tapa y estructura roble / Base laca microtexturada pizarra
Oak top and structure / Slate micro-textured lacquer base

Tapa mármol negro o blanco / Estructura laca / Base laca microtexturada pizarra
Black or white marble top / Lacquer structure / Slate micro-textured lacquer base

Tapa mármol negro o blanco / Estructura roble / Base laca microtexturada pizarra
Black or white marble top / Oak structure / Slate micro-textured lacquer base

DUO

PerezOchando



The Duo collection was born from the ambition to create a piece that is visually light and, at the same time, functional. The PerezOchando studio is known for playing with interesting shapes in its designs, and the inspiration for this

collection, based on the figure of the Japanese hashi chopsticks, leaves no one indifferent. It is a design with a balance between elegant and delicate.



The collection concentrates
functionality and versatility.



IDEAL FOR HOME AND CONTRACT USE

Duo adapts easily to any environment, both in the home and in contract projects. The top is available in various finishes, lacquer, oak, walnut, black glass, statuary ceramic and marble, to adapt to any space.









The top is available in white and black marble for the most most unique spaces.







DUO IN ALL TYPES OF ENVIRONMENTS

The Duo collection is characterised by its ease of adaptation to all types of environments, from hotels to office spaces, including home and contract, Duo blends in perfectly with its surroundings, offering personality and elegance in all its sizes.

In these pages Duo table with marble top and black microtextured structure.

Duo, individually or together

The collection offers a wide range of possibilities, working individually and together. Duo allows numerous customisation options thanks to its wide variety of finishes.

On the next page, Duo in marble top and fog top finish, both in black microtextured structure.



DESIGNED FOR ALL SPACES

“The Duo table blends design and craftsmanship, making it an extraordinary piece that transforms spaces into unique and timeless places.”



The Duo table is the perfect example of the sustainable and responsible design that we at Kendo have always taken care of sensitivity from the very beginning. It is a solution that, from the very beginning of its creation, has always had its own adaptability, personality and formality. The wide variety of finishes on the top allows for numerous unique

configurations that offer all kinds of variations in order to adapt perfectly to any type of space, including hotels, residential, offices, restaurants etc. The visual play offered by its legs, as well as its great versatility as a whole or on its own, make it a piece of industrial design destined to become an aesthetic icon of timelessness.

*On this page, some of our finishes
for the Duo table.*



Lacquer

Oak



Marble

Black glass



Walnut



*Duo at Casa Tide in Algorta, Vizcaya (Spain).
Project by IN 56.*





Finishes

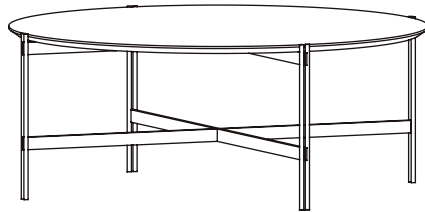

Tapa - Laca, roble, nogal, cristal negro, cerámica statuario, mármol negro o blanco
 Top - Lacquer, oak, walnut, black glass, statuario ceramic, black or white marble

Estructura - Metal termolacado negro microtexturado
 Structure - Micro-textured black thermo-lacquered metal



Blanco
White



Piedra
Stone

RAL 7044



Arena
Sand

NCS S2005-Y20R



Visión
Taupe

NCS S4005-Y20R



Grafito
Graphite

RAL 7022



Pizarra
Slate

NCS S8500-N



Negro
Black



Niebla
Fog

NCS S5005-B20G



Océano
Ocean

NCS S7010 B10G



Menta
Mint

NCS S3010 G20Y



Oliva
Olive

NCS S6010 G10Y



Bosque
Forest

NCS S7010 B90G



Teja
Tile

NCS S5030 Y90R



Roble natural
Natural oak



Roble claro
Light oak



Nogal natural
Natural Walnut



Roble teñido ceniza
Ash stained oak



Roble teñido tostado
Toasted stained oak



Roble teñido wengue
Wengue stained oak



Roble negro
Black oak



Cerámica Statuario
Statuario Ceramic



Mármol blanco
White marble



Mármol negro
Black marble



Cristal negro
Black glass

Technical specifications

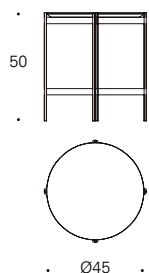

Tablero: Ø45 cm
Pata metálica (1): 1 cm
Medida final: Ø47 cm
Top: Ø45 cm
Metal leg (1): 1 cm
Final size: Ø47 cm

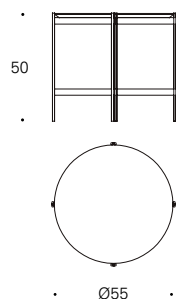

Tablero: Ø55 cm
Pata metálica (1): 1 cm
Medida final: Ø57 cm
Top: Ø55 cm
Metal leg (1): 1 cm
Final size: Ø57 cm

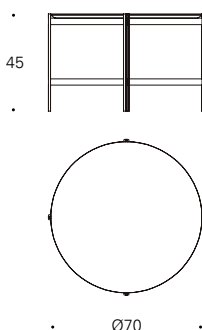

Tablero: Ø70 cm
Pata metálica (1): 1 cm
Medida final: Ø72 cm
Top: Ø70 cm
Metal leg (1): 1 cm
Final size: Ø72 cm

DUO-45R

Ø45x50 cm

Tapa laca / Estructura termolacada negro microtexturado
Lacquer top / Micro-textured black thermo-lacquered structure

Tapa roble / Estructura termolacada negro microtexturado
Oak top / Micro-textured black thermo-lacquered structure

Tapa nogal / Estructura termolacada negro microtexturado
Walnut top / Micro-textured black thermo-lacquered structure

Tapa cristal negro / Estructura termolacada negro microtexturado
Black glass top / Micro-textured black thermo-lacquered structure

Tapa cerámica statuario / Estructura termolacada negro microtexturado
Statuario ceramic top / Micro-textured black thermo-lacquered structure

Tapa mármol negro o blanco / Estructura termolacada negro microtexturado
Black or white marble top / Micro-textured black thermo-lacquered structure

DUO-55R

Ø55x50 cm

Tapa laca / Estructura termolacada negro microtexturado
Lacquer top / Micro-textured black thermo-lacquered structure

Tapa roble / Estructura termolacada negro microtexturado
Oak top / Micro-textured black thermo-lacquered structure

Tapa nogal / Estructura termolacada negro microtexturado
Walnut top / Micro-textured black thermo-lacquered structure

Tapa cristal negro / Estructura termolacada negro microtexturado
Black glass top / Micro-textured black thermo-lacquered structure

Tapa cerámica statuario / Estructura termolacada negro microtexturado
Statuario ceramic top / Micro-textured black thermo-lacquered structure

Tapa mármol negro o blanco / Estructura termolacada negro microtexturado
Black or white marble top / Micro-textured black thermo-lacquered structure

DUO-74R

Ø70x45 cm

Tapa laca / Estructura termolacada negro microtexturado
Lacquer top / Micro-textured black thermo-lacquered structure

Tapa roble / Estructura termolacada negro microtexturado
Oak top / Micro-textured black thermo-lacquered structure

Tapa nogal / Estructura termolacada negro microtexturado
Walnut top / Micro-textured black thermo-lacquered structure

Tapa cristal negro / Estructura termolacada negro microtexturado
Black glass top / Micro-textured black thermo-lacquered structure

Tapa cerámica statuario / Estructura termolacada negro microtexturado
Statuario ceramic top / Micro-textured black thermo-lacquered structure

Tapa mármol negro o blanco / Estructura termolacada negro microtexturado
Black or white marble top / Micro-textured black thermo-lacquered structure

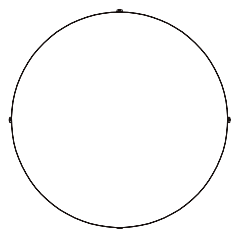
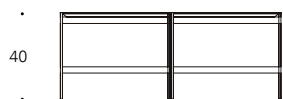

Ø100

Tablero: Ø100 cm
 Pata metálica (1): 1 cm
 Medida final: Ø102 cm
 Top: Ø100 cm
 Metal leg (1): 1 cm
 Final size: Ø102 cm

DUO-04R

Ø100x40 cm

Tapa laca / Estructura termolacada negro microtexturado
 Lacquer top / Micro-textured black thermo-lacquered structure

Tapa roble / Estructura termolacada negro microtexturado
 Oak top / Micro-textured black thermo-lacquered structure

Tapa nogal / Estructura termolacada negro microtexturado
 Walnut top / Micro-textured black thermo-lacquered structure

Tapa cristal negro / Estructura termolacada negro microtexturado
 Black glass top / Micro-textured black thermo-lacquered structure

Tapa cerámica statuario / Estructura termolacada negro microtexturado
 Statuario ceramic top / Micro-textured black thermo-lacquered structure

Tapa mármol negro o blanco / Estructura termolacada negro microtexturado
 Black or white marble top / Micro-textured black thermo-lacquered structure

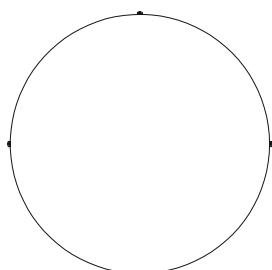
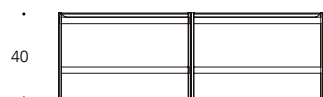

Ø120

Tablero: Ø120 cm
 Pata metálica (1): 1 cm
 Medida final: Ø122 cm
 Top: Ø120 cm
 Metal leg (1): 1 cm
 Final size: Ø122 cm

DUO-24R

Ø120x40 cm

Tapa laca / Estructura termolacada negro microtexturado
 Lacquer top / Micro-textured black thermo-lacquered structure

Tapa roble / Estructura termolacada negro microtexturado
 Oak top / Micro-textured black thermo-lacquered structure

Tapa nogal / Estructura termolacada negro microtexturado
 Walnut top / Micro-textured black thermo-lacquered structure

Tapa mármol negro o blanco / Estructura termolacada negro microtexturado
 Black or white marble top / Micro-textured black thermo-lacquered structure

IDRA

PerezOchando



The Idra collection has a simple geometry and a light base made up of multiple rods. These tables provide a very attractive and personal visual play in any environment.

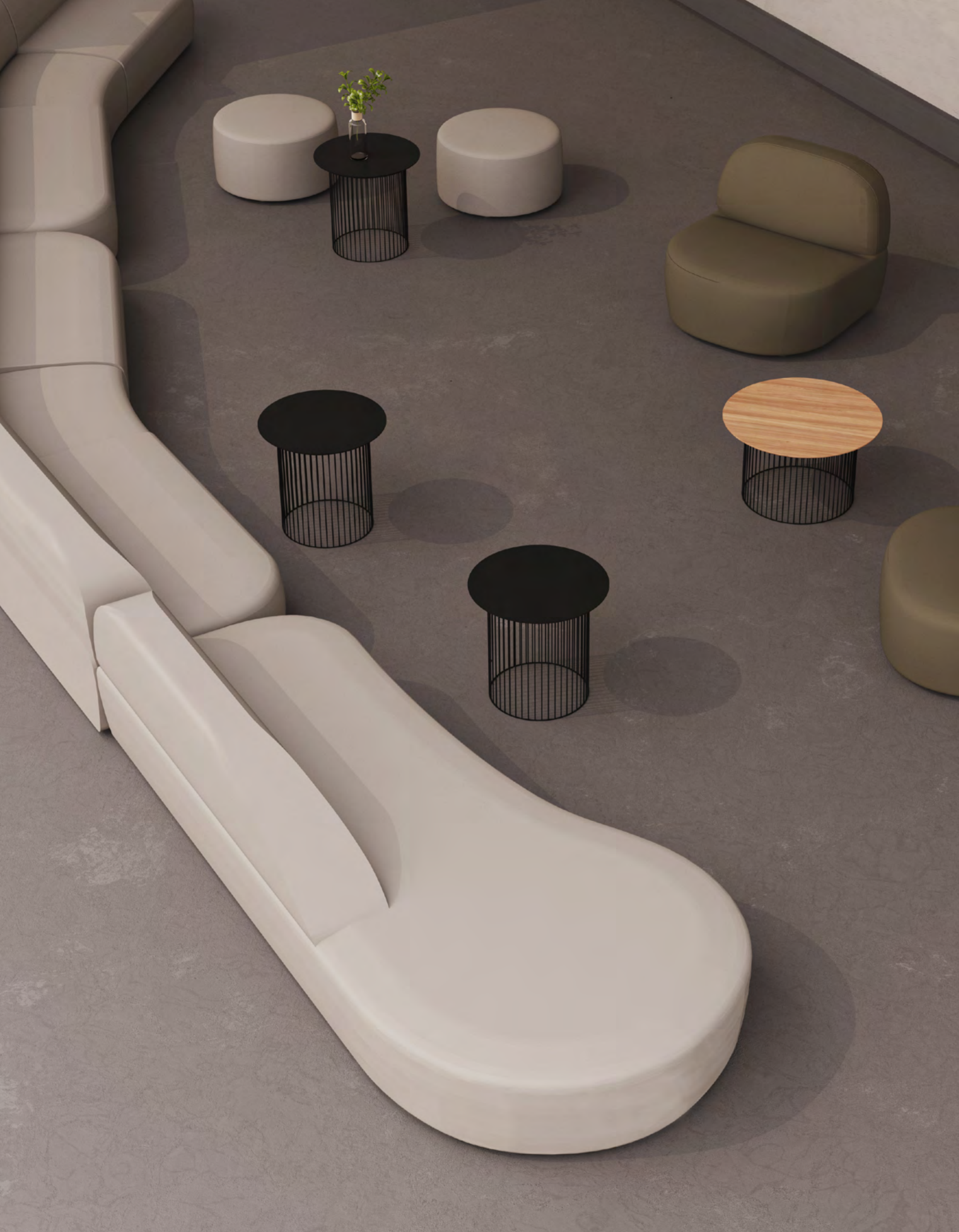





*Create your own Idra,
combine sizes and
choose finishes*

IDRA ø 55 x 52 cm
Compact slate



IDRA ø 70 x 40 cm
Sand

IDRA ø 45 x 50 cm
Olive

The Idra collection is the perfect combination of versatility and functionality. The wide range of finishes allows a whole world of possibilities to be explored, opening the door to play with different sizes and combinations. The enveloping shape of the legs, as well as the sensation of balance that they transmit, make Idra the perfect element in contract and home spaces, both as an auxiliary and as a centrepiece.



IDRA Ø 100 x 40 cm
Natural oak



IDRA Ø 70 x 40 cm
Fog



IDRA CONVEYS ITS ESSENCE

Idra offers a wide variety of materials and finishes in the top together with a metallic structure that can be in black or white thermo-lacquered lacquer. Its versatility also lies in the visual power of the table in different sizes, either to be placed as a whole or individually. Always showing an original, elegant and clean design that gives the space a touch of good taste and tranquility.



On this page, coffee table with stone lacquer finish and white microtextured thermo-lacquered structure together with side table with white lacquer finish and white microtextured thermo-lacquered structure.



*On these pages, above (left and right) Idra at Aldar Square HQ, Abu Dhabi (UAE).
Project by The Total Office.*

*Bottom right Idra at the Supreme Council for Motherhood and Childhood Office, Abu
Dhabi (UAE).
Project by The Total Office.*

Idra

Thanks to its easy blending in with its surroundings, Idra is an indispensable part of many spaces around the world.





*Idra at Aldar Square HQ, Abu Dhabi (UAE).
Project by The Total Office.*



On these pages, bedside table with mist lacquer finish and black structure (right) and also mink and ocean lacquer in different sizes with black structure.







IDRA IN INTERNATIONAL PROJECTS

Idra has become a benchmark and indispensable element for numerous national and international projects, partly because Idra's finishes provide great versatility to adapt the table to any type of installation. An example of the exclusivity that Idra can offer is the use of the top in compact slate, which helps to enhance the environment and blends in perfectly with the surroundings.

On the left page, Idra tables in the Le Loft project for Apartment 2 Lansell Road, Melbourne (Australia).

On this page (bottom), individual Idra table in the Le Loft project in Toorak, Melbourne (Australia).



Finishes

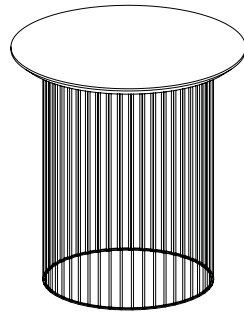

Tapa - Laca, roble, nogal, compacto pizarra, cristal negro, cerámica statuario
 Top - Lacquer, oak, walnut, slate compact, black glass, statuario ceramic

Estructura - Metal termolacado negro o blanco microtexturado
 Structure - Black or white thermo-lacquered micro-textured metal



Blanco
White



Piedra
Stone

RAL 7044



Arena
Sand

NCS S2005-Y20R



Visión
Taupe

NCS S4005-Y20R



Grafito
Graphite

RAL 7022



Pizarra
Slate

NCS S8500-N



Negro
Black



Niebla
Fog

NCS S5005-B20G



Océano
Ocean

NCS S7010 B10G



Menta
Mint

NCS S3010 G20Y



Oliva
Olive

NCS S6010 G10Y



Bosque
Forest

NCS S7010 B90G



Teja
Tile

NCS S5030 Y90R



Roble natural
Natural oak



Roble claro
Light oak



Nogal natural
Natural Walnut



Roble teñido ceniza
Ash stained oak



Roble teñido tostado
Toasted stained oak



Roble teñido wengue
Wengue stained oak



Roble negro
Black oak



Cerámica Statuario
Statuario Ceramic



Compacto pizarra
Slate compact



Cristal negro
Black glass

Idra by PerezOchando is a coffee table based on an attractive visual effect and reveals a taste for elegant and novel design, as well as contributing at the same time to generate a suitable atmosphere.

Its wide variety of finishes together with the different sizes available represents an opportunity for total customisation of a timeless and versatile design that makes it suitable for any project.



On this page Idra side tables in statuario ceramic, light oak and mint lacquer finishes.

Technical specifications

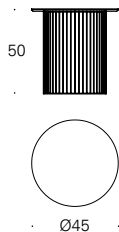

IDRA-45R Ø45x50 cm

Tapa laca / Estructura termolacada negro microtexturado
Lacquer top / Micro-textured black thermo-lacquered structure

Tapa roble / Estructura termolacada negro microtexturado
Oak top / Micro-textured black thermo-lacquered structure

Tapa nogal / Estructura termolacada negro microtexturado
Walnut top / Micro-textured black thermo-lacquered structure

Tapa compacto pizarra / Estructura termolacada negro microtexturado
Slate compact top / Micro-textured black thermo-lacquered structure

Tapa cristal negro / Estructura termolacada negro microtexturado
Black glass top / Micro-textured black thermo-lacquered structure

Tapa cerámica statuario / Estructura termolacada negro microtexturado
Statuario ceramic top / Micro-textured black thermo-lacquered structure

Opción estructura termolacada blanco microtexturado*
Micro-textured white thermo-lacquered structure option*

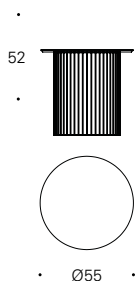

IDRA-55R Ø55x52 cm

Tapa laca / Estructura termolacada negro microtexturado
Lacquer top / Micro-textured black thermo-lacquered structure

Tapa roble / Estructura termolacada negro microtexturado
Oak top / Micro-textured black thermo-lacquered structure

Tapa nogal / Estructura termolacada negro microtexturado
Walnut top / Micro-textured black thermo-lacquered structure

Tapa compacto pizarra / Estructura termolacada negro microtexturado
Slate compact top / Micro-textured black thermo-lacquered structure

Tapa cristal negro / Estructura termolacada negro microtexturado
Black glass top / Micro-textured black thermo-lacquered structure

Tapa cerámica statuario / Estructura termolacada negro microtexturado
Statuario ceramic top / Micro-textured black thermo-lacquered structure

Opción estructura termolacada blanco microtexturado*
Micro-textured white thermo-lacquered structure option*

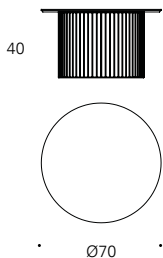
**IDRA-74R**

Ø70x40 cm

Tapa laca / Estructura termolacada negro microtexturado
Lacquer top / Micro-textured black thermo-lacquered structure

Tapa roble / Estructura termolacada negro microtexturado
Oak top / Micro-textured black thermo-lacquered structure

Tapa nogal / Estructura termolacada negro microtexturado
Walnut top / Micro-textured black thermo-lacquered structure

Tapa compacto pizarra / Estructura termolacada negro microtexturado
Slate compact top / Micro-textured black thermo-lacquered structure

Tapa cristal negro / Estructura termolacada negro microtexturado
Black glass top / Micro-textured black thermo-lacquered structure

Tapa cerámica statuario / Estructura termolacada negro microtexturado
Statuario ceramic top / Micro-textured black thermo-lacquered structure

Opción estructura termolacada blanco microtexturado*
Micro-textured white thermo-lacquered structure option*

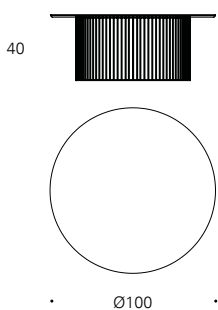
**IDRA-04R**

Ø100x40 cm

Tapa laca / Estructura termolacada negro microtexturado
Lacquer top / Micro-textured black thermo-lacquered structure

Tapa roble / Estructura termolacada negro microtexturado
Oak top / Micro-textured black thermo-lacquered structure

Tapa nogal / Estructura termolacada negro microtexturado
Walnut top / Micro-textured black thermo-lacquered structure

Tapa compacto pizarra / Estructura termolacada negro microtexturado
Slate compact top / Micro-textured black thermo-lacquered structure

Tapa cristal negro / Estructura termolacada negro microtexturado
Black glass top / Micro-textured black thermo-lacquered structure

Tapa cerámica statuario / Estructura termolacada negro microtexturado
Statuario ceramic top / Micro-textured black thermo-lacquered structure

Opción estructura termolacada blanco microtexturado*
Micro-textured white thermo-lacquered structure option*

TOTEM

Gabriel Teixidó



Totem is a TV stand with a 360° rotation. Its purist lines allow it to be placed in different spaces. It comes in several sizes with a functional and simple system for collecting cables.

It comes in several sizes to adapt easily to a home, office or hotel. In addition, it can rotate so that the television can be enjoyed comfortably in two different areas within the same space.



Wide swivel range for comfort and versatility

On these pages, Totem in the Paradores project, in the Parador de Cádiz (Spain).







Totem offers great comfort in all kinds of spaces. Its swivelling options and the wide variety of finishes it offers make it a totally indispensable piece of furniture in terms of elegance, refinement and timeless design.



On this page, profile view of Totem, and some of the finishes, forest, sand and ocean.







ELEGANCE AND DESIGN, TOTEM

In addition to the dynamism offered by the Totem swivel, it houses the cables inside so that they are not visible and can generate an undesired visual effect. Its shelf in the lower area guarantees absolute comfort as it allows all kinds of objects to be placed on it, thus facilitating connections and providing well-being.

On these pages, detail in Totem's turn.





*Totem in Hotel Neptuno in
Valencia (España).
Project by Espai Guixeres.*

On this page, a visual guide to the Totem turn in sand finish.



Balance, elegance
and versatility.



REAR SIDE

Totem incorporates a removable panel at the back that allows cables to be hidden inside so that only what is visually favourable in the space is visible.

VERSATILITY AND DISTINCTION

Totem is capable of adapting to all kinds of spaces, whether they are offices, waiting rooms, management offices, suites... Always offering the necessary versatility to create several different spaces in the same room.

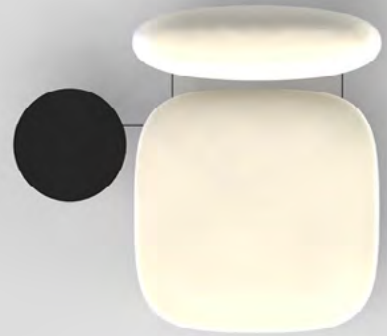

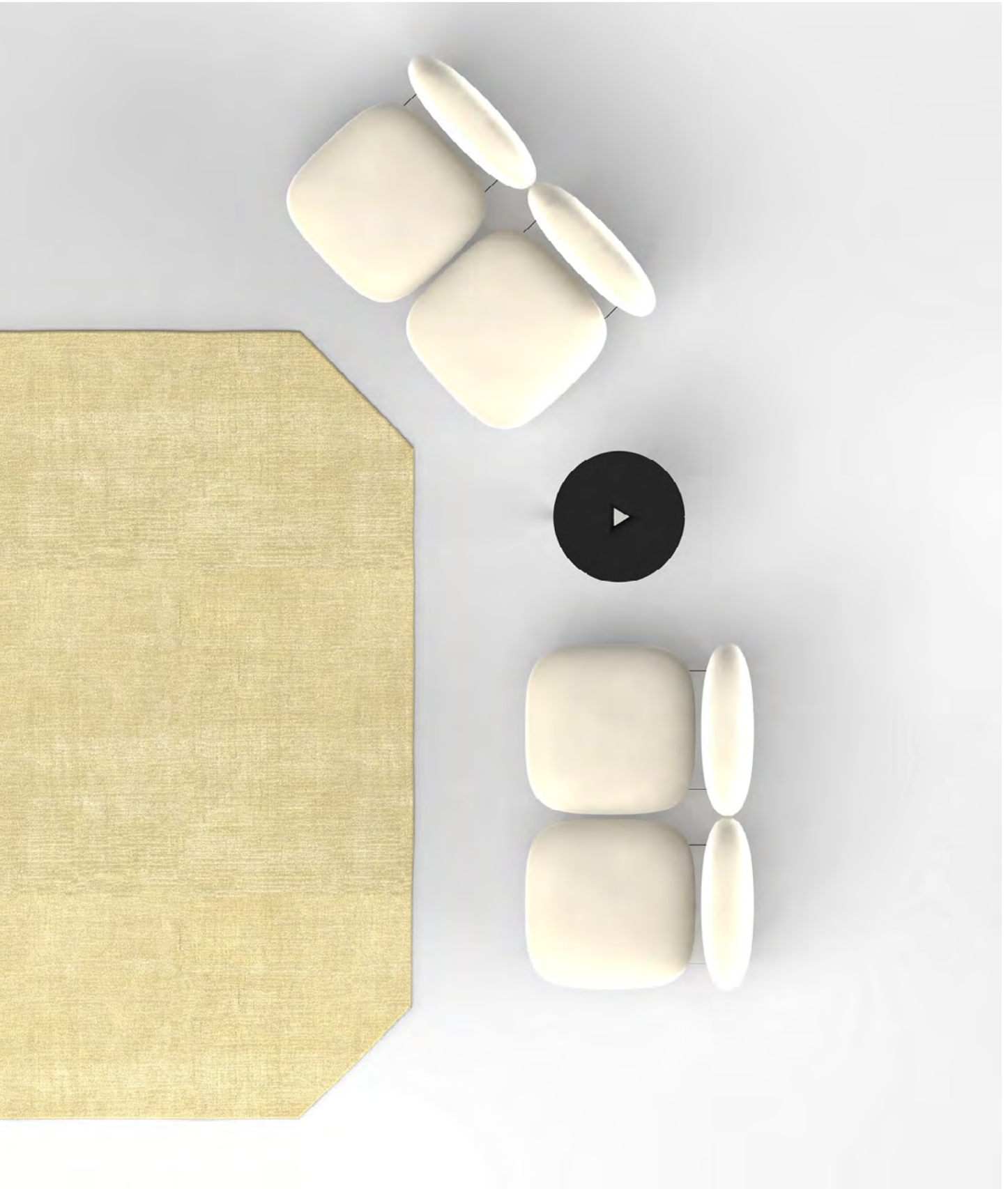

Finishes

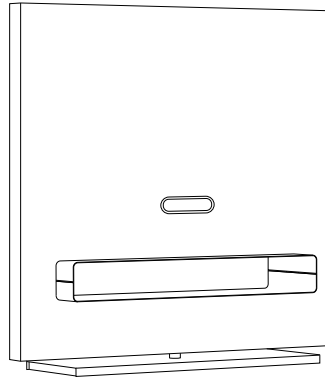

Blanco
White



Piedra
Stone
RAL 7044



Arena
Sand
NCS S2005-Y20R



Visión
Taupe
NCS S4005-Y20R



Grafito
Graphite
RAL 7022



Pizarra
Slate
NCS S8500-N



Negro
Black



Niebla
Fog
NCS S5005-B20G



Océano
Ocean
NCS S7010 B10G



Menta
Mint
NCS S3010 G20Y



Oliva
Olive
NCS S6010 G10Y



Bosque
Forest
NCS S7010 B90G



Teja
Tile
NCS S5030 Y90R

Technical specifications

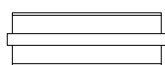
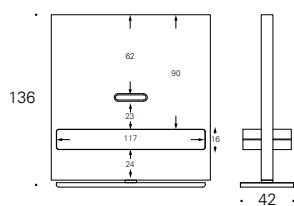

125

TV-24

125x42x136 cm

Panel laca / Estantes y base termolacados negro microtexturado
Lacquer panel / Micro-textured black thermo-lacquered structure and base

Panel laca / Estantes y base acero inoxidable
Lacquer panel / Stainless steel structure and base

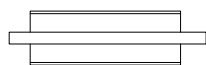
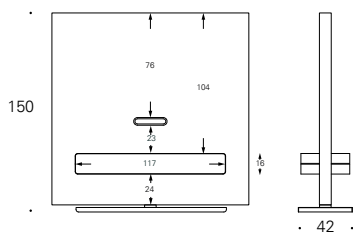

148

TV-44

148x42x150 cm

Panel laca / Estantes y base termolacados negro microtexturado
Lacquer panel / Micro-textured black thermo-lacquered structure and base

Panel laca / Estantes y base acero inoxidable
Lacquer panel / Stainless steel structure and base

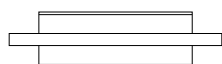
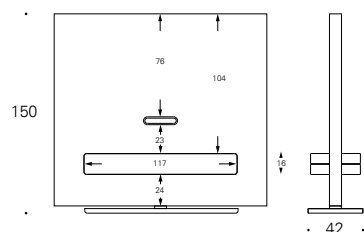

160

TV-64

160x42x150 cm

Panel laca / Estantes y base termolacados negro microtexturado
Lacquer panel / Micro-textured black thermo-lacquered structure and base

Panel laca / Estantes y base acero inoxidable
Lacquer panel / Stainless steel structure and base

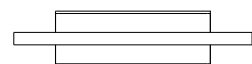
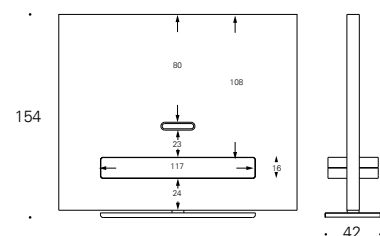

180

TV-84

180x42x154 cm

Panel laca / Estantes y base termolacados negro microtexturado
Lacquer panel / Micro-textured black thermo-lacquered structure and base

Panel laca / Estantes y base acero inoxidable
Lacquer panel / Stainless steel structure and base

RITA

Elegance

Antoni Arola

The Rita table transports us to a geometric universe of straight lines and planes that connect in a surprising way with the architectural spaces of its surroundings and reveal a wide range of possible uses. Its elegance in simplicity provides a unique design solution that blends in with many types of rooms and interiors.





*Rita at C93, Mallorca (España).
Project by Perello Mobles.*







*Residential at Puerto Andratx, Mallorca (España).
Interior design by Estudio Vidal Piñeiro.*

Its exact proportions make this table a piece that works perfectly as a whole or individually. Always giving the environment a touch of distinction and design that perfectly guarantees the timelessness of the furniture.



*Hotel Neptuno, Valencia (España).
Project by Espai Guixeres.*







*Biniatru House, Palma (España).
Project by Negre.*

DESIGN AND ELEGANCE

Thanks to its particular and elegant design, Rita is the ideal element to place in the centre of the room, as it brings together and enhances the originality of the environment, creating a perfect synthesis. It is a table with a sober, honest and timeless character that adds a unique touch to the room with the play of materials between the structure and the top.

*Rita Table in Gros, Donosti (Spain).
Project by Nuvan.*







In the Rita collection, the visual of transparency is observed together with the straightness and simplicity of flatness. With its intrinsic natural elegance and its different sizes and finishes, it becomes a unique piece of great aesthetic value.

The tables are composed of a thermo-lacquered metal structure in micro-textured black, a base and vertical sides, which can be customised in lacquer, walnut or oak, and a grey smoked glass top.



Amalgam of
geometry and elegance







Finishes

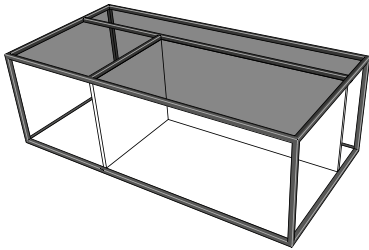

Tapa - Cristal templado fumé gris 10 mm de espesor
 Top - 10 mm-thick smoked grey tempered glass

Estructura - Metal termolacado negro microtexturado
 Opción laca*
 Structure - Micro-textured black thermo-lacquered metal
 Lacquer option*

Base y costados - Roble, nogal, laca
 Base and vertical sides - Oak, walnut, lacquer



Blanco
White



Piedra
Stone

RAL 7044



Arena
Sand

NCS S2005-Y20R



Visión
Taupe

NCS S4005-Y20R



Grafito
Graphite

RAL 7022



Pizarra
Slate

NCS S8500-N



Negro
Black



Niebla
Fog

NCS S5005-B20G



Océano
Ocean

NCS S7010 B10G



Menta
Mint

NCS S3010 G20Y



Oliva
Olive

NCS S6010 G10Y



Bosque
Forest

NCS S7010 B90G



Teja
Tile

NCS S5030 Y90R



Cristal fumé gris
Smoked grey glass



Roble natural
Natural oak



Roble claro
Light oak



Nogal natural
Natural Walnut



Roble teñido ceniza
Ash stained oak



Roble teñido tostado
Toasted stained oak



Roble teñido wengue
Wengue stained oak



Roble negro
Black oak

Technical specifications

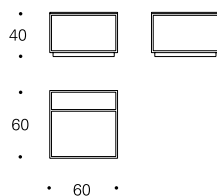

RITA-66 60x60x40 cm

Tapa cristal fumé gris / Base y costados laca
Smoked grey glass top / Lacquer base and vertical sides

Tapa cristal fumé gris / Base y costados nogal
Smoked grey glass top / Walnut base and vertical sides

Tapa cristal fumé gris / Base y costados roble
Smoked grey glass top / Oak base and vertical sides

Acabado estructura: termolacada negro microtexturado
Structure finish: Micro-textured black thermo-lacquered

Opción estructura laca*
Option lacquer structure*

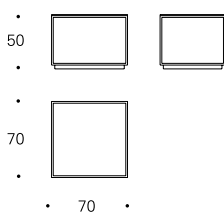

RITA-77 70x70x50 cm

Tapa cristal fumé gris / Base laca
Smoked grey glass top / Lacquer base

Tapa cristal fumé gris / Base nogal
Smoked grey glass top / Walnut base

Tapa cristal fumé gris / Base roble
Smoked grey glass top / Oak base

Acabado estructura: termolacada negro microtexturado
Structure finish: Micro-textured black thermo-lacquered

Opción estructura laca*
Option lacquer structure*

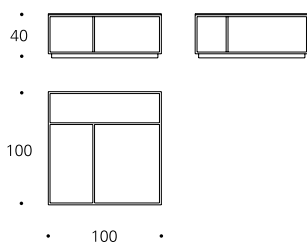

RITA-00 100x100x40 cm

Tapa cristal fumé gris / Base y costados laca
Smoked grey glass top / Lacquer base and vertical sides

Tapa cristal fumé gris / Base y costados nogal
Smoked grey glass top / Walnut base and vertical sides

Tapa cristal fumé gris / Base y costados roble
Smoked grey glass top / Oak base and vertical sides

Acabado estructura: termolacada negro microtexturado
Structure finish: Micro-textured black thermo-lacquered

Opción estructura laca*
Option lacquer structure*

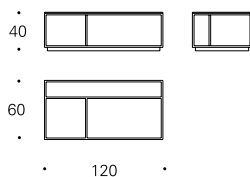
**RITA-26**

120x60x40 cm

Tapa cristal fumé gris / Base y costados laca
Smoked grey glass top / Lacquer base and vertical sides

Tapa cristal fumé gris / Base y costados nogal
Smoked grey glass top / Walnut base and vertical sides

Tapa cristal fumé gris / Base y costados roble
Smoked grey glass top / Oak base and vertical sides

Acabado estructura: termolacada negro microtexturado
Structure finish: Micro-textured black thermo-lacquered

Opción estructura laca*
Option lacquer structure*

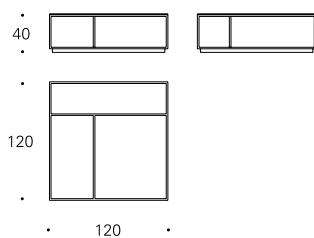
**RITA-22**

120x120x40 cm

Tapa cristal fumé gris / Base y costados laca
Smoked grey glass top / Lacquer base and vertical sides

Tapa cristal fumé gris / Base y costados nogal
Smoked grey glass top / Walnut base and vertical sides

Tapa cristal fumé gris / Base y costados roble
Smoked grey glass top / Oak base and vertical sides

Acabado estructura: termolacada negro microtexturado
Structure finish: Micro-textured black thermo-lacquered

Opción estructura laca*
Option lacquer structure*

Rita Console

The Rita console is one of the great pieces of this collection. Versatile, elegant and apparently simple, shows with its straight lines and planes that the geometry integrated in the product is one of the keys to success, always offering adaptability and good taste to spaces.







Timeless ELEGANCE

The console is an element that combines practicality and decoration in its own concept. Rita is a functional console that at the same time draws attention to its design and the quality of the materials, treated from the beginning of its processing in a handcrafted, natural, sustainable and responsible way. The wide variety of finishes of this console allows it to be incorporated into all kinds of environments and scenes where the design of a piece that transmits transparency, simplicity and balance provides a point of exquisite and timeless elegance. The Rita console is not just another element of an exclusive collection, it is a way of understanding the environment, the design, the practicality and the way of being of the furniture, it is a passion, that from the beginning of its creation has been carved to become what it is today, a classic.





It is a distinguished piece that raises the level of any environment. It is a versatile and easily adaptable proposal.

Finishes

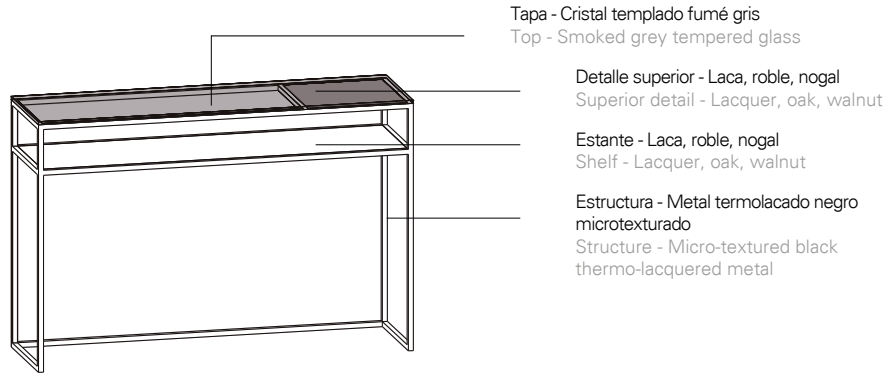

Tapa - Cristal templado fumé gris
Top - Smoked grey tempered glass

Detalle superior - Laca, roble, nogal
Superior detail - Lacquer, oak, walnut

Estante - Laca, roble, nogal
Shelf - Lacquer, oak, walnut

Estructura - Metal termolacado negro
microtexturado
Structure - Micro-textured black
thermo-lacquered metal



Blanco
White



Piedra
Stone
RAL 7044



Arena
Sand
NCS S2005-Y20R



Visión
Taupe
NCS S4005-Y20R



Grafito
Graphite
RAL 7022



Pizarra
Slate
NCS S8500-N



Negro
Black



Niebla
Fog
NCS S5005-B20G



Océano
Ocean
NCS S7010 B10G



Menta
Mint
NCS S3010 G20Y



Oliva
Olive
NCS S6010 G10Y



Bosque
Forest
NCS S7010 B90G



Teja
Tile
NCS S5030 Y90R



Cristal fumé gris
Smoked grey glass



Roble natural
Natural oak



Roble claro
Light oak



Nogal natural
Natural Walnut



Roble teñido ceniza
Ash stained oak



Roble teñido tostado
Toasted stained oak



Roble teñido wengue
Wengue stained oak



Roble negro
Black oak

Technical specifications

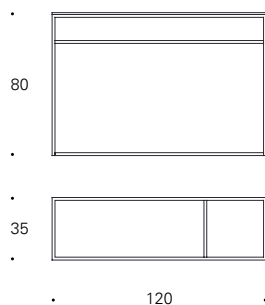

RITY-23

120x35x80 cm

Tapa cristal fumé gris / Estante laca
Smoked grey glass top / Lacquer shelf

Tapa cristal fumé gris / Estante roble
Smoked grey glass top / Oak shelf

Tapa cristal fumé gris / Estante nogal
Smoked grey glass top / Walnut shelf

Acabado detalle superior: mismo acabado del estante
Superior detail finish: same finish as the shelf

Acabado estructura: termolacada negro microtexturado
Structure finish: Micro-textured black thermo-lacquered



Rita desk

The Rita desk is one of the essential components of this product family. Its lightness, transparency and shelf make it a unique working space where organisation and comfort are the prerequisites for success.







On these pages, Rita desk with black lacquered shelf and black microtextured thermo-lacquered structure.

Rita offers the possibility, to make the environment a whole

Its conjunction with the rest of the pieces in the collection is maximum, giving the environment the sensation of being a whole, of which the different parts offer their personality, dynamism and substantial balance.





Finishes

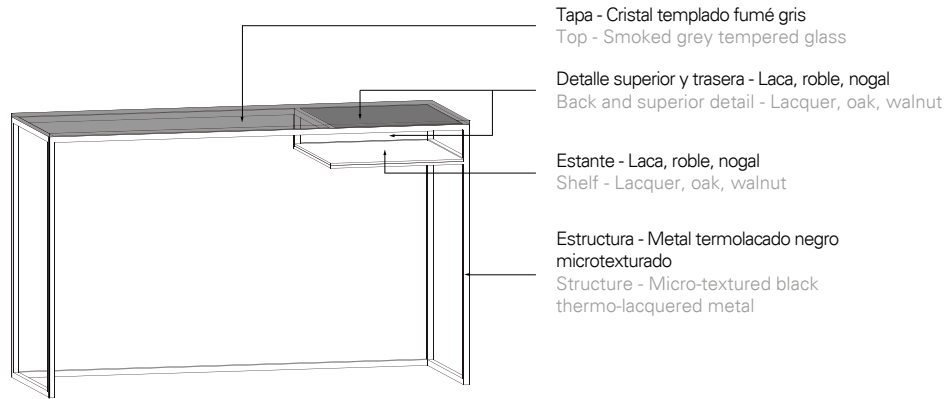

Blanco
White



Piedra
Stone
RAL 7044



Arena
Sand
NCS S2005-Y20R



Visión
Taupe
NCS S4005-Y20R



Grafito
Graphite
RAL 7022



Pizarra
Slate
NCS S8500-N



Negro
Black



Niebla
Fog
NCS S5005-B20G



Océano
Ocean
NCS S7010 B10G



Menta
Mint
NCS S3010 G20Y



Oliva
Olive
NCS S6010 G10Y



Bosque
Forest
NCS S7010 B90G



Teja
Tile
NCS S5030 Y90R



Cristal fumé gris
Smoked grey glass



Roble natural
Natural oak



Roble claro
Light oak



Nogal natural
Natural Walnut



Roble teñido ceniza
Ash stained oak



Roble teñido tostado
Toasted stained oak



Roble teñido wengue
Wengue stained oak



Roble negro
Black oak

Technical specifications

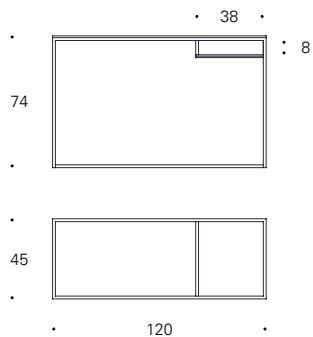

RITP-24

120x45x74 cm

Tapa cristal fumé gris / Estante laca
Smoked grey glass top / Lacquer shelf

Tapa cristal fumé gris / Estante nogal
Smoked grey glass top / Walnut shelf

Tapa cristal fumé gris / Estante roble
Smoked grey glass top / Oak shelf

Acabado detalle superior y trasera: mismo acabado del estante
Back and superior detail finish: same finish as the shelf

Acabado estructura: termolacada negro microtexturado
Structure finish: Micro-textured black thermo-lacquered



Rita Bookcase

The bookcase is design, elegance and mastery in a single piece. The finesse of its shelves together with simplicity, which is the essence of this collection, offer style and balance to one of the indispensable products in terms of organisation, exquisiteness and adaptability.



KEY IDEAS

The Rita bookcase expresses the simple elegance of timelessness in a light vision of sober furniture, which allows it to be placed in contexts and environments of all kinds.

Designed by Antoni Arola, as well as this entire collection, its lines and planes convey the poetic vision of the most original and magnificent design, always transmitting calm and tranquillity with its leading morphology. The wide variety of finishes allows absolute personalisation of an essential piece of furniture where design, craftsmanship and elegance are an indivisible whole.





*On this page Rita bookcase, walnut finish,
next to Rita desk.*



Always evoking tranquillity and good design, Rita gives us the combination of its parts to express in the environment a unique, poetic and simple whole.

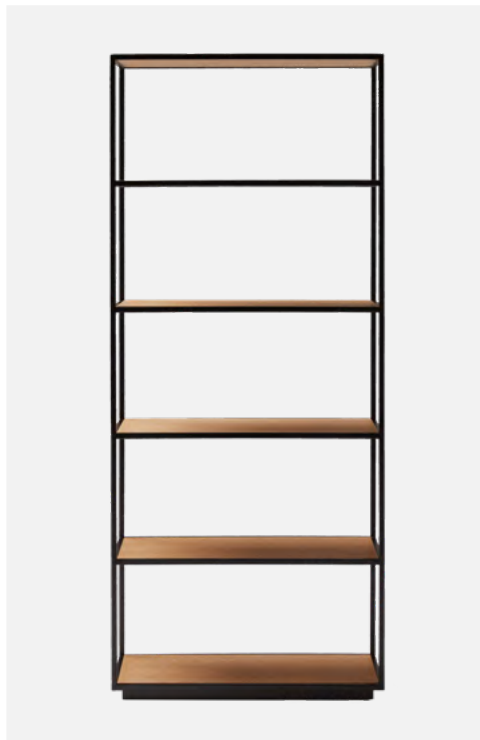

Rita, elegance in
essence

Finishes

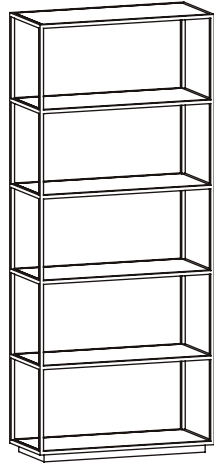

Estantes - Laca, roble, nogal
Shelves - Lacquer, oak, walnut

Estructura - Metal termolacado negro
microtexturado
Structure - Micro-textured black
thermo-lacquered metal



Blanco
White



Piedra
Stone
RAL 7044



Arena
Sand
NCS S2005-Y20R



Visión
Taupe
NCS S4005-Y20R



Grafito
Graphite
RAL 7022



Pizarra
Slate
NCS S8500-N



Negro
Black



Niebla
Fog
NCS S5005-B20G



Océano
Ocean
NCS S7010 B10G



Menta
Mint
NCS S3010 G20Y



Oliva
Olive
NCS S6010 G10Y



Bosque
Forest
NCS S7010 B90G



Teja
Tile
NCS S5030 Y90R



Cristal fumé gris
Smoked grey glass



Roble natural
Natural oak



Roble claro
Light oak



Nogal natural
Natural Walnut



Roble teñido ceniza
Ash stained oak



Roble teñido tostado
Toasted stained oak



Roble teñido wengue
Wengue stained oak



Roble negro
Black oak

Technical specifications

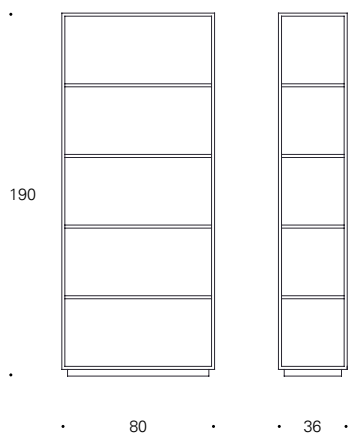

RITK-83 80x36x190 cm

Estantes laca
Lacquer shelves

Estantes roble
Oak shelves

Estantes nogal
Walnut shelves

Acabado estructura: termolacada negro microtexturado
Structure finish: Micro-textured black thermo-lacquered

RITA LITE

Antoni Arola



The Rita Lite coffee table, an extension of the Rita collection, stands out for its balance of visual lightness. Thanks to the architecture of its structure and the finishes it offers, the table brings elegance to any environment.







RITA LITE, VARIETY IN VERSATILITY

The Rita Lite collection allows an easy integration of the furniture in any interior thanks to the innumerable combination of its finishes. Therefore, offering versatility and customisation to the user's taste, always standing out for the simplicity of elegance and the integration of all the elements in one.

Coffee table with black marble finish, black lacquer and black microtextured thermo-lacquered structure.







The Rita Lite collection, characterised by its formal and elegant style, is composed of a top available in different finishes such as grey smoked tempered glass or marble, a structure in black micro-textured thermo-lacquered metal and a base in lacquer, oak or walnut finish.



Rita Lite,
design,
timelessness,
simplicity.





Finishes



Tapa - Cristal templado fumé gris, mármol negro o blanco
 Top - Smoked grey tempered glass, black or white marble

Estructura - Metal termolacado negro microtexturado, opción en laca*
 Structure - Micro-textured black thermo-lacquered metal, optionally in lacquer*

Base - Laca, nogal, roble
 Shelf - Lacquer, walnut, oak



Blanco
White



Piedra
Stone

RAL 7044



Arena
Sand

NCS S2005-Y20R



Visión
Taupe

NCS S4005-Y20R



Grafito
Graphite

RAL 7022



Pizarra
Slate

NCS S8500-N



Negro
Black



Niebla
Fog

NCS S5005-B20G



Océano
Ocean

NCS S7010 B10G



Menta
Mint

NCS S3010 G20Y



Oliva
Olive

NCS S6010 G10Y



Bosque
Forest

NCS S7010 B90G



Teja
Tile

NCS S5030 Y90R



Roble natural
Natural oak



Roble claro
Light oak



Nogal natural
Natural Walnut



Roble teñido ceniza
Ash stained oak



Roble teñido tostado
Toasted stained oak



Roble teñido wengue
Wengue stained oak



Roble negro
Black oak



Cristal fumé gris
Smoked grey glass



Mármol blanco
White marble



Mármol negro
Black marble

Technical specifications

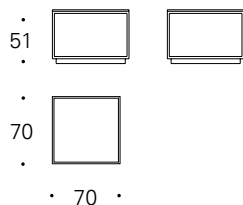

RITALITE-77 70x70x51 cm

Tapa cristal fumé gris / Base laca
Smoked grey glass top / Lacquer base

Tapa cristal fumé gris / Base nogal
Smoked grey glass top / Walnut base

Tapa cristal fumé gris / Base roble
Smoked grey glass top / Oak base

Tapa mármol negro o blanco / Base laca
Black or white marble top / Lacquer base

Tapa mármol negro o blanco / Base nogal
Black or white marble top / Walnut base

Tapa mármol negro o blanco / Base roble
Black or white marble top / Oak base

Acabado estructura: termolacada negro microtexturado
Structure finish: Micro-textured black thermo-lacquered

Opción estructura laca*
Lacquer structure option*

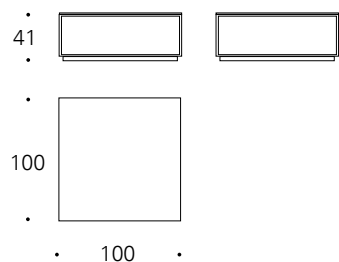

RITALITE-00 100x100x41 cm

Tapa cristal fumé gris / Base laca
Smoked grey glass top / Lacquer base

Tapa cristal fumé gris / Base nogal
Smoked grey glass top / Walnut base

Tapa cristal fumé gris / Base roble
Smoked grey glass top / Oak base

Tapa mármol negro o blanco / Base laca
Black or white marble top / Lacquer base

Tapa mármol negro o blanco / Base nogal
Black or white marble top / Walnut base

Tapa mármol negro o blanco / Base roble
Black or white marble top / Oak base

Acabado estructura: termolacada negro microtexturado
Structure finish: Micro-textured black thermo-lacquered

Opción estructura laca*
Lacquer structure option*

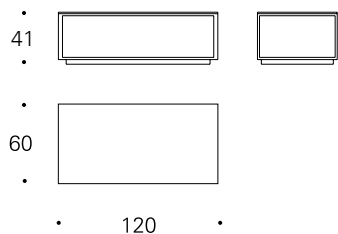
**RITALITE-26**

120x60x41 cm

Tapa cristal fumé gris / Base laca
Smoked grey glass top / Lacquer base

Tapa cristal fumé gris / Base nogal
Smoked grey glass top / Walnut base

Tapa cristal fumé gris / Base roble
Smoked grey glass top / Oak base

Tapa mármol negro o blanco / Base laca
Black or white marble top / Lacquer base

Tapa mármol negro o blanco / Base nogal
Black or white marble top / Walnut base

Tapa mármol negro o blanco / Base roble
Black or white marble top / Oak base

Acabado estructura: termolacada negro microtexturado
Structure finish: Micro-textured black thermo-lacquered

Opción estructura laca*
Lacquer structure option*

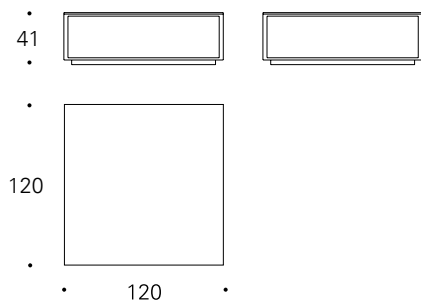
**RITALITE-22**

120x120x41 cm

Tapa cristal fumé gris / Base laca
Smoked grey glass top / Lacquer base

Tapa cristal fumé gris / Base nogal
Smoked grey glass top / Walnut base

Tapa cristal fumé gris / Base roble
Smoked grey glass top / Oak base

Acabado estructura: termolacada negro microtexturado
Structure finish: Micro-textured black thermo-lacquered

Opción estructura laca*
Lacquer structure option*



Rita lite auxiliary console

The combination of its finishes facilitates the integration of the furniture into any interior. Materials such as glass, lacquer, walnut and oak achieve a great harmony between them and, at the same time, complete the space.



*On this page, Rita Lite side console with
black glass top and black lacquer base.*







The top of the side console is available in smoked tempered glass while the base can be in oak, walnut or lacquer. The structure is available in a choice of black micro-textured thermo-lacquered finish or lacquer.



Finishes

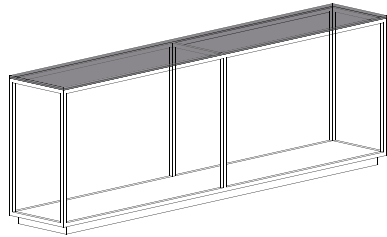

Tapa - Cristal templado fumé gris 10 mm de espesor
 Top - 10 mm-thick smoked grey tempered glass

Estructura - Metal termolacado negro microtexturado,
 opción en laca*
 Structure - Micro-textured black thermo-lacquered metal,
 optionally in lacquer*

Base - Laca, nogal, roble
 Shelf - Lacquer, walnut, oak



Blanco
White



Piedra
Stone
RAL 7044



Arena
Sand
NCS S2005-Y20R



Visión
Taupe
NCS S4005-Y20R



Grafito
Graphite
RAL 7022



Pizarra
Slate
NCS S8500-N



Negro
Black



Niebla
Fog
NCS S5005-B20G



Océano
Ocean
NCS S7010 B10G



Menta
Mint
NCS S3010 G20Y



Oliva
Olive
NCS S6010 G10Y



Bosque
Forest
NCS S7010 B90G



Teja
Tile
NCS S5030 Y90R



Cristal fumé gris
Smoked grey glass



Roble natural
Natural oak



Roble claro
Light oak



Nogal natural
Natural Walnut



Roble teñido ceniza
Ash stained oak



Roble teñido tostado
Toasted stained oak



Roble teñido wengue
Wengue stained oak



Roble negro
Black oak

Technical specifications

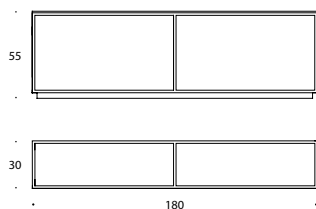

RITALY-83

180x30x55 cm

Tapa cristal fumé gris / Base roble
Smoked grey glass top / Oak base

Tapa cristal fumé gris / Base nogal
Smoked grey glass top / Walnut base

Tapa cristal fumé gris / Base laca
Smoked grey glass top / Lacquer base

Acabado estructura: termolacada negro microtexturado
Structure finish: Micro-textured black thermo-lacquered

Opción estructura laca*
Option lacquer structure*

BECO

Luis Arrivillaga



The essence of the present and the past are reflected in Beco, a desk with a warm and welcoming look, in which every detail is designed to feel the beauty of its materials. Its lift-up top reveals an interior space with a highly functional sliding tray.







● Taupe

Beco adapts perfectly to an office space or a hotel room where a homely feel is sought after. A very practical and original solution that thanks to its natural finishes brings warmth to the room. The desk is available in two different sizes,

making it very versatile for any type of room. It offers the possibility of being fixed or having an elevating top, adding a useful storage space, with a sliding tray inside to organise and store work objects.



● Graphite



On these pages Beco desk in Ash Oak finish.

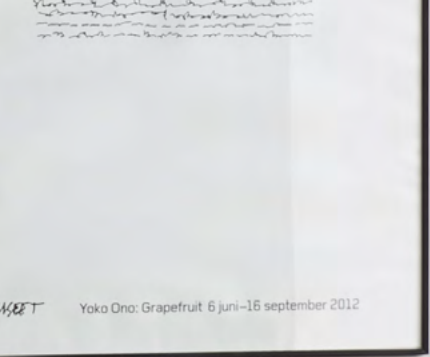



Beco,
unique,
practical and
original



FUNCTIONAL ELEGANCE

Beco is the perfect example of functionality and elegance. Its simple shape as well as its incredible practicality make this piece an indispensable element in numerous projects of all kinds, both nationally and internationally.

*Beco desk at Hotel Kongress Davos in Davos (Switzerland).
Project by Wilhelm Architektur.*

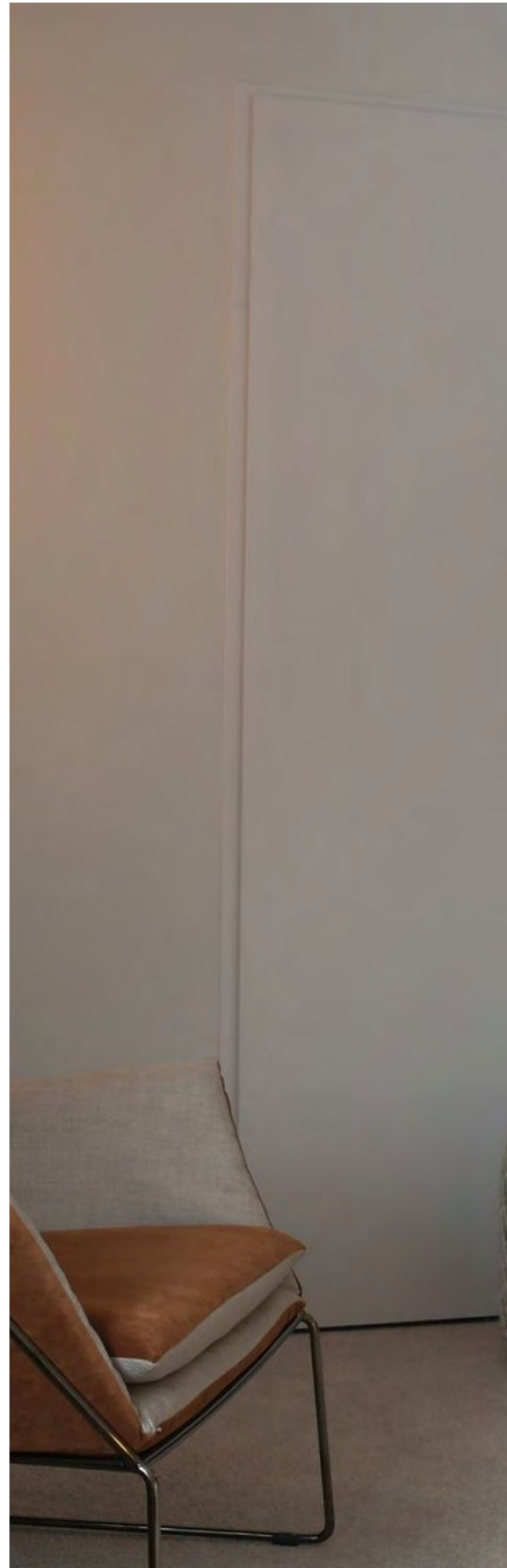





● Light oak



● Walnut



Finishes

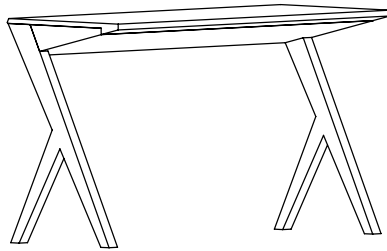

Blanco
White



Piedra
Stone
RAL 7044



Arena
Sand
NCS S2005-Y20R



Visón
Taupe
NCS S4005-Y20R



Grafito
Graphite
RAL 7022



Pizarra
Slate
NCS S8500-N



Negro
Black



Niebla
Fog
NCS S5005-B20G



Océano
Ocean
NCS S7010 B10G



Menta
Mint
NCS S3010 G20Y



Oliva
Olive
NCS S6010 G10Y



Bosque
Forest
NCS S7010 B90G



Teja
Tile
NCS S5030 Y90R



Roble natural
Natural oak



Roble claro
Light oak



Nogal natural
Natural Walnut



Roble teñido ceniza
Ash stained oak



Roble teñido tostado
Toasted stained oak



Roble teñido wengue
Wengue stained oak



Roble negro
Black oak

Technical specifications

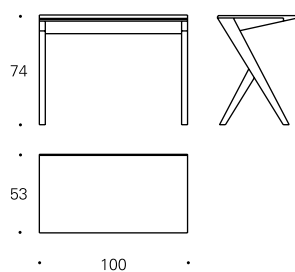

BECO-05 F Tapa fija
Fixed top 100x53x74 cm

Roble
Oak

Nogal
Walnut

Laca
Lacquer

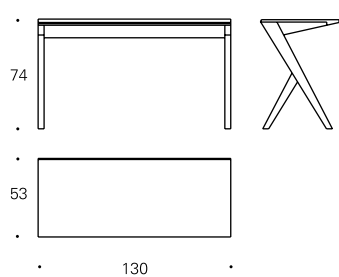

BECO-35 F Tapa fija
Fixed top 130x53x74 cm

Roble
Oak

Nogal
Walnut

Laca
Lacquer

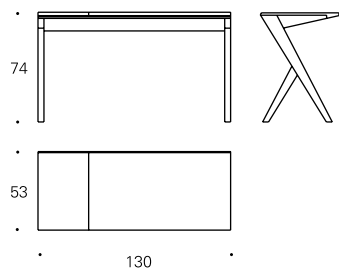

BECO-35 E Tapa elevable
Folding top 130x53x74 cm

Roble
Oak

Nogal
Walnut

EXO

PerezOchando



The EXO collection consists of tables, consoles and television furniture. It is characterised by a metal structure that forms an essential part of the design. Its perfect combination with the materials of the top and the shelf make for an elegant and unique ensemble.





EXO guarantees total customisation of your design to create exclusive, made-to-measure tables. Its different shapes, morphologies and sizes as well as the number of finishes available for shelf and top make it the versatility par excellence.



In these pages EXO coffee table in toasted oak top and stone lacquer shelf finish.



*Mallorcair Private Aviation Terminal,
Mallorca (Spain).
Project by Marga Comas Interior Design.*

EXO is fundamentally characterised by its versatility and originality. The immense number of combinations and finishes make this design a piece that blends in perfectly with all kinds of environments and settings, always adding its own particular touch.

Selected for projects all over the world, EXO guarantees quality, stability and prominence in the centre of any room thanks to its rounded tops and light legs. It stands out for the balance of its forms and raises the level of the environment.









*Mallorcair Private Aviation Terminal, Mallorca (Spain)
Project by Marga Comas Interior Design.*



EXO tables are available in different finishes such as oak, walnut or lacquer together with their structure in black micro-textured thermo-lacquered metal.







*Gran Canet Residencial, Valencia (Spain).
Project by ORSAL.*

Finishes

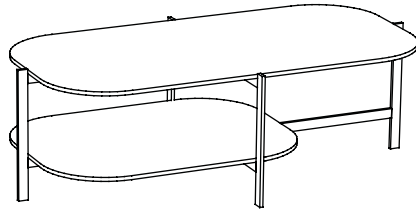

Tapa - Laca, roble, nogal
Top - Lacquer, oak, walnut

Estructura - Metal termolacado negro microtexturado, opción en laca*
Structure - Micro-textured black thermo-lacquered metal, optionally in lacquer*

Estante - Laca
Shelf - Lacquer



Blanco
White



Piedra
Stone
RAL 7044



Arena
Sand
NCS S2005-Y20R



Visión
Taupe
NCS S4005-Y20R



Grafito
Graphite
RAL 7022



Pizarra
Slate
NCS S8500-N



Negro
Black



Niebla
Fog
NCS S5005-B20G



Océano
Ocean
NCS S7010 B10G



Menta
Mint
NCS S3010 G20Y



Oliva
Olive
NCS S6010 G10Y



Bosque
Forest
NCS S7010 B90G



Teja
Tile
NCS S5030 Y90R



Roble natural
Natural oak



Roble claro
Light oak



Nogal natural
Natural Walnut



Roble teñido ceniza
Ash stained oak



Roble teñido tostado
Toasted stained oak



Roble teñido wengue
Wengue stained oak



Roble negro
Black oak





Finishes

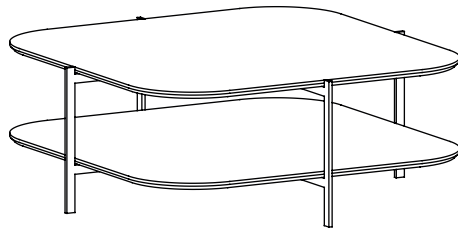

Tapa - Laca, roble
Top - Lacquer, oak

Estructura - Metal termolacado negro microtexturado, opción en laca*
Structure - Micro-textured black thermo-lacquered metal, optionally in lacquer*

Estante - Laca
Shelf - Lacquer

Finishes for sizes 60x60, and 100x100 cm



Blanco
White



Piedra
Stone

RAL 7044



Arena
Sand

NCS S2005-Y20R



Visión
Taupe

NCS S4005-Y20R



Grafito
Graphite

RAL 7022



Pizarra
Slate

NCS S8500-N



Negro
Black



Niebla
Fog

NCS S5005-B20G



Océano
Ocean

NCS S7010 B10G



Menta
Mint

NCS S3010 G20Y



Oliva
Olive

NCS S6010 G10Y



Bosque
Forest

NCS S7010 B90G



Teja
Tile

NCS S5030 Y90R



Roble natural
Natural oak



Roble claro
Light oak



Roble teñido ceniza
Ash stained oak



Roble teñido tostado
Toasted stained oak



Roble teñido wengue
Wengue stained oak



Roble negro
Black oak

Technical specifications

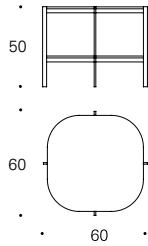

Tablero: 60x60 cm
 Pata metálica (1): 2,5 cm
 Medida final: 65x65 cm

Top: 60x60 cm
 Metal leg (1): 2,5 cm
 Final size: 65x65 cm

EXO-66 60x60x50 cm

Tapa laca / Estructura termolacada negro microtexturado
 Lacquer top / Micro-textured black thermo-lacquered structure

Tapa roble / Estructura termolacada negro microtexturado
 Oak top / Micro-textured black thermo-lacquered structure

Acabado estante: Laca
 Shelf finish: Lacquer

Opción estructura laca*
 Lacquer structure option*

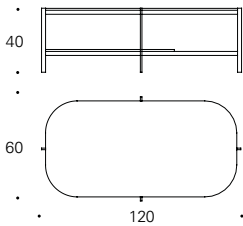

Tablero: 120x60 cm
 Pata metálica (1): 2,5 cm
 Medida final: 125x65 cm

Top: 120x60 cm
 Metal leg (1): 2,5 cm
 Final size: 125x65 cm

EXO-26 120x60x40 cm

Tapa laca / Estructura termolacada negro microtexturado
 Lacquer top / Micro-textured black thermo-lacquered structure

Tapa roble / Estructura termolacada negro microtexturado
 Oak top / Micro-textured black thermo-lacquered structure

Tapa nogal / Estructura termolacada negro microtexturado
 Walnut top / Micro-textured black thermo-lacquered structure

Acabado estante: Laca
 Shelf finish: Lacquer

Opción estructura laca*
 Lacquer structure option*

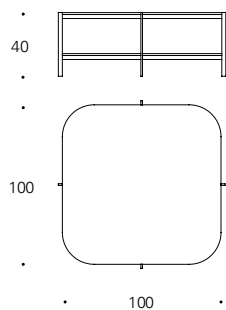

Tablero: 100x100 cm
 Pata metálica (1): 2,5 cm
 Medida final: 105x105 cm

Top: 100x100 cm
 Metal leg (1): 2,5 cm
 Final size: 105x105 cm

EXO-00

100x100x40 cm

Tapa laca / Estructura termolacada negro microtexturado
 Lacquer top / Micro-textured black thermo-lacquered structure

Tapa roble / Estructura termolacada negro microtexturado
 Oak top / Micro-textured black thermo-lacquered structure

Acabado estante: Laca
 Shelf finish: Lacquer

Opción estructura laca*
 Lacquer structure option*

EXO TV furniture

The EXO collection includes the television unit whose measurements and finishes make it easy to adapt to both the home and installations. It is a solution that forms part of a very versatile collection.





It is available in four different sizes that allow it to adapt to the needs of each room. Due to the wide variety of colours it offers, it can be easily integrated into any interior.



Finishes

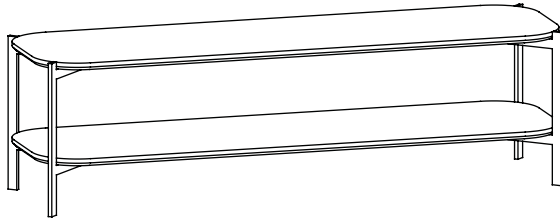

Tapa - Laca
Top - Lacquer

Estructura - Metal termolacado negro microtexturado, opción en laca*
Structure - Micro-textured black thermo-lacquered metal, optionally in lacquer*

Estante - Laca
Shelf - Lacquer



Blanco
White



Piedra
Stone
RAL 7044



Arena
Sand
NCS S2005-Y20R



Visión
Taupe
NCS S4005-Y20R



Grafito
Graphite
RAL 7022



Pizarra
Slate
NCS S8500-N



Negro
Black



Niebla
Fog
NCS S5005-B20G



Océano
Ocean
NCS S7010 B10G



Menta
Mint
NCS S3010 G20Y



Oliva
Olive
NCS S6010 G10Y



Bosque
Forest
NCS S7010 B90G



Teja
Tile
NCS S5030 Y90R

Technical specifications

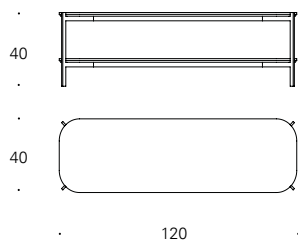

EXOV-24 120x40x40 cm

Tapa Laca / Estructura termolacada negro microtexturado
Lacquer top / Micro-textured black thermo-lacquered structure

Acabado estante: Laca
Shelf finish: Lacquer

Opción estructura laca*
Lacquer structure option*

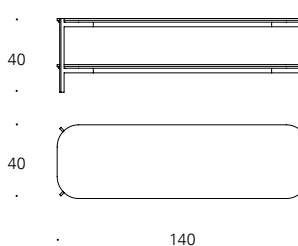

EXOV-44 140x40x40 cm

Tapa Laca / Estructura termolacada negro microtexturado
Lacquer top / Micro-textured black thermo-lacquered structure

Acabado estante: Laca
Shelf finish: Lacquer

Opción estructura laca*
Lacquer structure option*

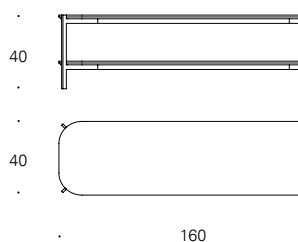

EXOV-64 160x40x40 cm

Tapa Laca / Estructura termolacada negro microtexturado
Lacquer top / Micro-textured black thermo-lacquered structure

Acabado estante: Laca
Shelf finish: Lacquer

Opción estructura laca*
Lacquer structure option*

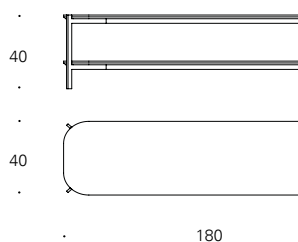

EXOV-84 180x40x40 cm

Tapa Laca / Estructura termolacada negro microtexturado
Lacquer top / Micro-textured black thermo-lacquered structure

Acabado estante: Laca
Shelf finish: Lacquer

Opción estructura laca*
Lacquer structure option*

EXO console

The EXO console is a unique piece that stands out as a functional and visually light solution, capable of adapting to any space.

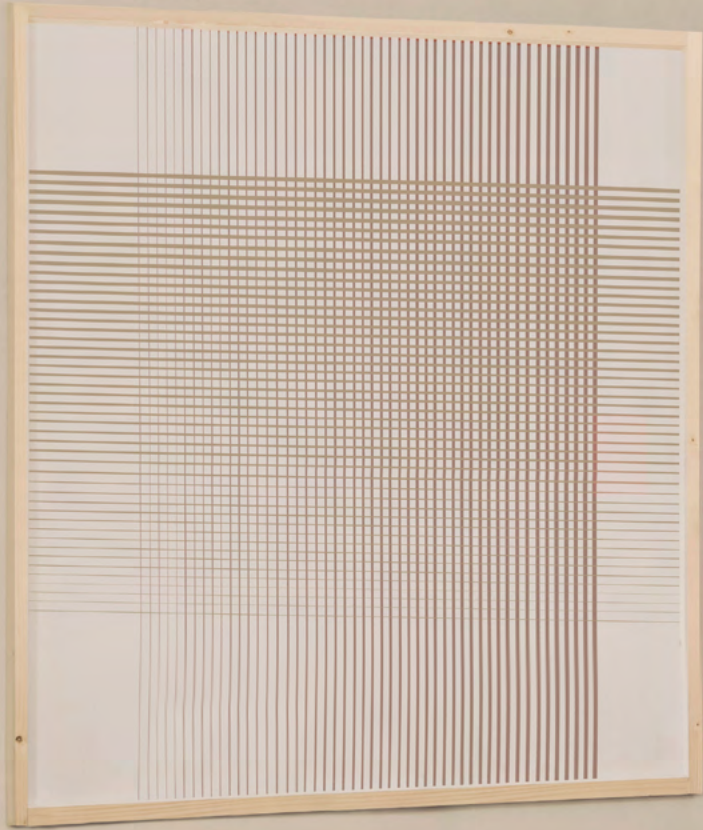





A versatile proposal and in various finishes

*On the left, console table in mink finish, on
the right console table in graphite and stone
finishes.*

EXO console with top in ash oak finish, black lacquered shelf and black microtextured structure.





Finishes

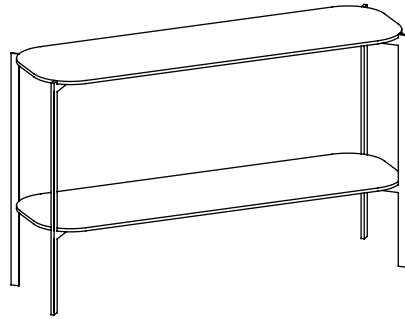

Tapa - Laca, roble
Top - Lacquer, oak

Estructura - Metal termolacado negro microtexturado, opción en laca*
Structure - Micro-textured black thermo-lacquered metal, optionally in lacquer*

Estante - Laca
Shelf - Lacquer



Blanco
White



Piedra
Stone
RAL 7044



Arena
Sand
NCS S2005-Y20R



Visión
Taupe
NCS S4005-Y20R



Grafito
Graphite
RAL 7022



Pizarra
Slate
NCS S8500-N



Negro
Black



Niebla
Fog
NCS S5005-B20G



Océano
Ocean
NCS S7010 B10G



Menta
Mint
NCS S3010 G20Y



Oliva
Olive
NCS S6010 G10Y



Bosque
Forest
NCS S7010 B90G



Teja
Tile
NCS S5030 Y90R



Roble natural
Natural oak



Roble claro
Light oak



Roble teñido ceniza
Ash stained oak



Roble teñido tostado
Toasted stained oak



Roble teñido wengue
Wengue stained oak



Roble negro
Black oak

Technical specifications

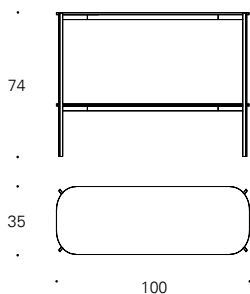

EXOY-03

100x35x74 cm

Tapa laca / Estructura termolacada negro microtexturado
Lacquer top / Micro-textured black thermo-lacquered structure

Tapa roble / Estructura termolacada negro microtexturado
Oak top / Micro-textured black thermo-lacquered structure

Acabado estante: Laca
Shelf finish: Lacquer

Opción estructura laca*
Lacquer structure option*

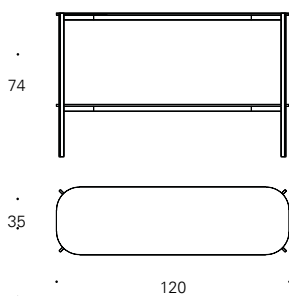

EXOY-23

120x35x74 cm

Tapa laca / Estructura termolacada negro microtexturado
Lacquer top / Micro-textured black thermo-lacquered structure

Tapa roble / Estructura termolacada negro microtexturado
Oak top / Micro-textured black thermo-lacquered structure

Acabado estante: Laca
Shelf finish: Lacquer

Opción estructura laca*
Lacquer structure option*

EXO auxiliary console

The finishes of the top and the shelf make it easy to adapt EXO both in the home and in installations. A very original and practical solution that creates the personality of the room.





Side console with ash oak finish, black lacquered shelf and black thermo-lacquered structure.



INTEGRATION AND PRACTICALITY

Its perfect mimicry with the sofa and the environment make this console table the perfect element to separate spaces within the same room and bring elegance and a touch of good taste to the whole environment thanks to its simple shapes and its appearance of light and original furniture.





Side console with light oak finish, light oak shelf and taupe thermo-lacquered structure.





Unique SPACES

The console is an example of the variety and possibilities offered by a great design such as EXO, taken to other types of product such as auxiliary consoles. With its practicality, elegance and design, the EXO auxiliary console is an indispensable piece of furniture. The wide variety of finishes of this console table allows it to blend in with all types of environments and spaces where the design perfectly conveys the distinction of spaces. Its dimensions make it the ideal complement to be placed behind the sofa, offering comfort and practicality in total harmony with the originality of the collection.

Finishes

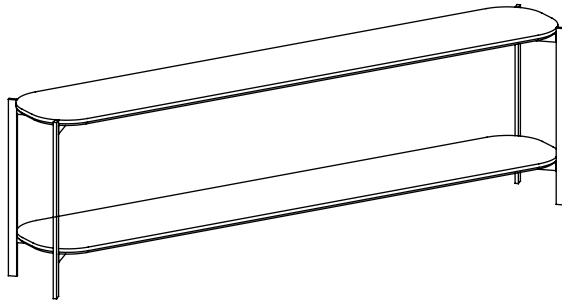

Tapa - Laca, roble
Top - Lacquer, oak

Estante - Laca, roble
Shelf - Lacquer, oak

Estructura - Metal termolacado negro microtexturado, opción en laca*
Structure - Micro-textured black thermo-lacquered metal, optionally in lacquer*



Blanco
White



Piedra
Stone
RAL 7044



Arena
Sand
NCS S2005-Y20R



Visión
Taupe
NCS S4005-Y20R



Grafito
Graphite
RAL 7022



Pizarra
Slate
NCS S8500-N



Negro
Black



Niebla
Fog
NCS S5005-B20G



Océano
Ocean
NCS S7010 B10G



Menta
Mint
NCS S3010 G20Y



Oliva
Olive
NCS S6010 G10Y



Bosque
Forest
NCS S7010 B90G



Teja
Tile
NCS S5030 Y90R



Roble natural
Natural oak



Roble claro
Light oak



Roble teñido ceniza
Ash stained oak



Roble teñido tostado
Toasted stained oak



Roble teñido wengue
Wengue stained oak



Roble negro
Black oak

Technical specifications

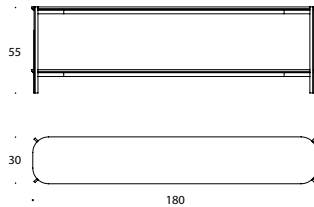

EXOY-83

180x30x55 cm

Tapa laca / Estructura termolacada negro microtexturado
Lacquer top / Micro-textured black thermo-lacquered structure

Tapa roble / Estructura termolacada negro microtexturado
Oak top / Micro-textured black thermo-lacquered structure

Acabado estante: Laca o roble
Shelf finish: Lacquer or oak

Opción estructura laca*
Option lacquer structure*

EXO ROUND

PerezOchando



The EXO Round coffee table collection is characterised by its simple elegance and functionality. Its perfect combination with noble materials creates an elegant and distinguished ensemble.







Side table with white marble and tile lacquer finish.





IDEAL FOR ALL TYPES OF SPACES

The EXO Round table offers customisation possibilities that make it a unique and timeless model. The wide variety of finishes and sizes makes this table adaptable to all kinds of spaces.



On this page, EXO Round table in white marble and ash oak finish (top). EXO Round table in ash oak and graphite finish (below).





IN DETAIL

In our origins, our intention has always been to create tables that can bring great personality to the space where they are placed, tables that can totally blend in with their surroundings, not only with the rest of the furniture, but also with small details such as carpets, lamps, decorative elements, etc. That is why we are proud of our EXO Round table, which meets these requirements to perfection while guaranteeing quality and elegance in all its finishes and sizes.

*On these pages, EXO Round in the Aldar Square project in Abu Dhabi (UAE).
Project by The Total Office.*





*Residential Home in front of the Turia Gardens in Valencia (Spain).
Project by Laura Yerpes.*

ROUND your EXO

EXO ROUND: ENLARGEMENT

The EXO Round collection is the extension of the EXO collection. The incorporation of finishes such as walnut and marble in all sizes makes it easy to adapt to different spaces.



On the right page, side table with white marble finish, sand lacquer and sand lacquer structure.





Finishes

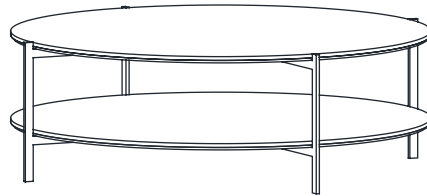

Tapa - Laca, roble, nogal, cristal negro, mármol negro o blanco, cerámica statuario
 Top - Lacquer, oak, walnut, black mirror, black or white marble, statuario ceramic
 Estructura - Metal termolacado negro microtexturado, opción en laca*
 Structure - Micro-textured black thermo-lacquered metal, optionally in lacquer*
 Estante - Laca, opción roble o nogal*
 Shelf - Lacquer, optionally in oak or walnut*



Blanco
White



Piedra
Stone

RAL 7044



Arena
Sand

NCS S2005-Y20R



Visión
Taupe

NCS S4005-Y20R



Grafito
Graphite

RAL 7022



Pizarra
Slate

NCS S8500-N



Negro
Black



Niebla
Fog

NCS S5005-B20G



Océano
Ocean

NCS S7010 B10G



Menta
Mint

NCS S3010 G20Y



Oliva
Olive

NCS S6010 G10Y



Bosque
Forest

NCS S7010 B90G



Teja
Tile

NCS S5030 Y90R



Roble natural
Natural oak



Roble claro
Light oak



Nogal natural
Natural Walnut



Roble teñido ceniza
Ash stained oak



Roble teñido tostado
Toasted stained oak



Roble teñido wengue
Wengue stained oak



Roble negro
Black oak



Cerámica Statuario
Statuario Ceramic



Mármol blanco
White marble



Mármol negro
Black marble



Cristal negro
Black glass

Technical specifications



55



• Ø55 •

Tablero: Ø55 cm
Pata metálica (1): 2,5 cm
Medida final: Ø60 cm

Top: Ø55 cm
Metal leg (1): 2,5 cm
Final size: Ø60 cm

EXO-55R

Ø55x55 cm

Tapa laca / Estructura termolacada negro microtexturado
Lacquer top / Micro-textured black thermo-lacquered structure

Tapa roble / Estructura termolacada negro microtexturado
Oak top / Micro-textured black thermo-lacquered structure

Tapa nogal / Estructura termolacada negro microtexturado
Walnut top / Micro-textured black thermo-lacquered structure

Tapa cristal negro / Estructura termolacada negro microtexturado
Black glass top / Micro-textured black thermo-lacquered structure

Tapa cerámica statuario / Estructura termolacada negro microtexturado
Statuario ceramic top / Micro-textured black thermo-lacquered structure

Tapa mármol negro o blanco / Estructura termolacada negro microtexturado
Black or white marble top / Micro-textured black thermo-lacquered structure

Acabado estante: Laca
Shelf finish: Lacquer

Opción acabado estante: Roble*
Option shelf finish: Oak*

Opción acabado estante: Nogal*
Option shelf finish: Walnut*

Opción estructura laca*
Lacquer structure option*

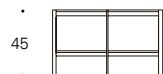

45

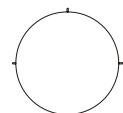

• Ø70 •

Tablero: Ø70 cm
Pata metálica (1): 2,5 cm
Medida final: Ø75 cm

Top: Ø70 cm
Metal leg (1): 2,5 cm
Final size: Ø75 cm

EXO-74R

Ø70x45 cm

Tapa laca / Estructura termolacada negro microtexturado
Lacquer top / Micro-textured black thermo-lacquered structure

Tapa roble / Estructura termolacada negro microtexturado
Oak top / Micro-textured black thermo-lacquered structure

Tapa nogal / Estructura termolacada negro microtexturado
Walnut top / Micro-textured black thermo-lacquered structure

Tapa cristal negro / Estructura termolacada negro microtexturado
Black glass top / Micro-textured black thermo-lacquered structure

Tapa cerámica statuario / Estructura termolacada negro microtexturado
Statuario ceramic top / Micro-textured black thermo-lacquered structure

Tapa mármol negro o blanco / Estructura termolacada negro microtexturado
Black or white marble top / Micro-textured black thermo-lacquered structure

Opción acabado estante: Roble*
Option shelf finish: Oak*

Opción acabado estante: Nogal*
Option shelf finish: Walnut*

Opción estructura laca*
Lacquer structure option*

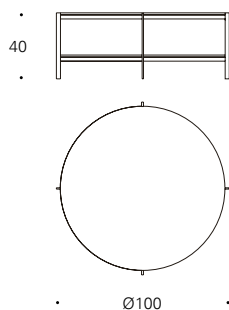

Tablero: Ø100 cm
Pata metálica (1): 2,5 cm
Medida final: Ø105 cm

Top: Ø100 cm
Metal leg (1): 2,5 cm
Final size: Ø105 cm

EXO-04R

Ø100x40 cm

Tapa laca / Estructura termolacada negro microtexturado
Lacquer top / Micro-textured black thermo-lacquered structure

Tapa roble / Estructura termolacada negro microtexturado
Oak top / Micro-textured black thermo-lacquered structure

Tapa nogal / Estructura termolacada negro microtexturado
Walnut top / Micro-textured black thermo-lacquered structure

Tapa cristal negro / Estructura termolacada negro microtexturado
Black glass top / Micro-textured black thermo-lacquered structure

Tapa cerámica statuario / Estructura termolacada negro microtexturado
Statuario ceramic top / Micro-textured black thermo-lacquered structure

Tapa mármol negro o blanco / Estructura termolacada negro microtexturado
Black or white marble top / Micro-textured black thermo-lacquered structure

Acabado estante: Laca
Shelf finish: Lacquer

Opción acabado estante: Roble*
Option shelf finish: Oak*

Opción acabado estante: Nogal*
Option shelf finish: Walnut*

Opción estructura laca*
Lacquer structure option*

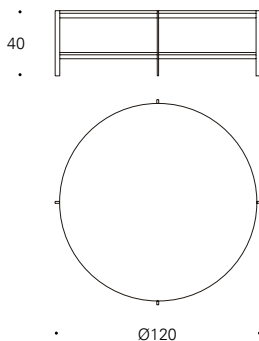

Tablero: Ø120 cm
Pata metálica (1): 2,5 cm
Medida final: Ø125 cm

Top: Ø120 cm
Metal leg (1): 2,5 cm
Final size: Ø125 cm

EXO-24R

Ø120x40 cm

Tapa laca / Estructura termolacada negro microtexturado
Lacquer top / Micro-textured black thermo-lacquered structure

Tapa roble / Estructura termolacada negro microtexturado
Oak top / Micro-textured black thermo-lacquered structure

Tapa nogal / Estructura termolacada negro microtexturado
Walnut top / Micro-textured black thermo-lacquered structure

Tapa mármol negro o blanco / Estructura termolacada negro microtexturado
Black or white marble top / Micro-textured black thermo-lacquered structure

Acabado estante: Laca
Shelf finish: Lacquer

Opción acabado estante: Roble*
Option shelf finish: Oak*

Opción acabado estante: Nogal*
Option shelf finish: Walnut*

Opción estructura laca*
Lacquer structure option*

NARUK

Vicente Gallega



Naruk is a collection of consoles whose apparently simple lines reveal a highly suggestive play of inclined planes. The console has two swivel trays concealed in the lower part of the top.



KENDO

NARUK

The presence of Naruk in entrances and corridors makes the difference, it stands out for its easy integration in both residential and installations, always providing its exclusive touch of particular elegance without claiming excessive prominence. It is a unique, simple and practical solution.





KEY IDEAS

The Naruk console is a design based on simplicity, geometry and a play of planes, providing a unique visual effect that combines perfectly with the opening of the drawers it incorporates.

This formulation by Vicente Gallega is a unique piece that presents the simple and technical vision of a console with a lot of personality, simple and sober. Its classic formality, as well as technical innovation and a wide variety of finishes make Naruk the perfect example of the versatility of elegant furniture.







Finishes

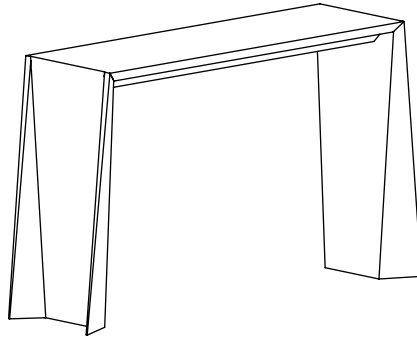

Blanco
White



Piedra
Stone
RAL 7044



Arena
Sand
NCS S2005-Y20R



Visón
Taupe
NCS S4005-Y20R



Grafito
Graphite
RAL 7022



Pizarra
Slate
NCS S8500-N



Negro
Black



Niebla
Fog
NCS S5005-B20G



Océano
Ocean
NCS S7010 B10G



Menta
Mint
NCS S3010 G20Y



Oliva
Olive
NCS S6010 G10Y



Bosque
Forest
NCS S7010 B90G



Teja
Tile
NCS S5030 Y90R



Roble natural
Natural oak



Roble claro
Light oak



Nogal natural
Natural Walnut



Roble teñido ceniza
Ash stained oak



Roble teñido tostado
Toasted stained oak



Roble teñido wengue
Wengue stained oak



Roble negro
Black oak

Technical specifications

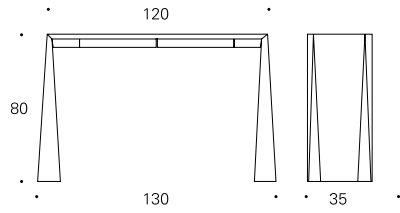

NY-33	Con bandejas With trays	130x35x80 cm
Nogal Walnut		
Roble Oak		
Laca Lacquer		

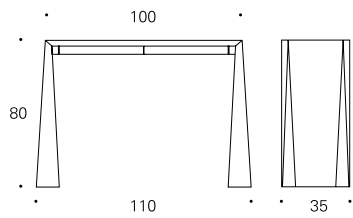

NY-13	Con bandejas With trays	110x35x80 cm
Nogal Walnut		
Roble Oak		
Laca Lacquer		

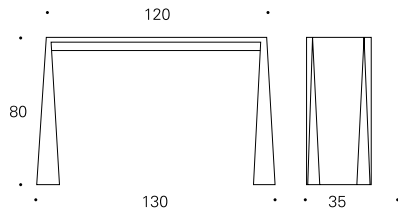

NY-33 SB Sin bandejas Without trays 130x35x80 cm

Nogal
Walnut

Roble
Oak

Laca
Lacquer

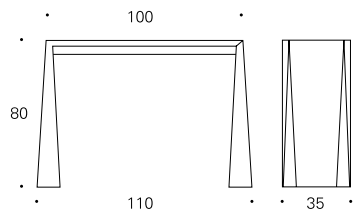

NY-13 SB Sin bandejas Without trays 110x35x80 cm

Nogal
Walnut

Roble
Oak

Laca
Lacquer

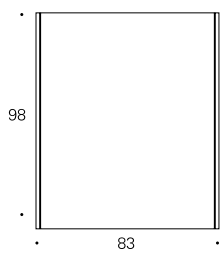

NX-03 Espejo Mirror 83x98 cm

Nogal
Walnut

Roble
Oak

Laca
Lacquer

Naruk desk

The Naruk desk has a perfectly studied arrangement of the angles and folds that make this piece not only cover the practical function but also make it an object of easy coexistence in different environments at the same time that it is an aesthetic icon.





Naruk has has a wide variety of finishes

The desk integrates perfectly in its minimalist set a pull-out drawer, with a useful hollow of 65x32x4cm.



Through its original combination of planes, Naruk provides the perfect visual play that conveys elegance, tranquillity and calm in all its finishes.



Functional
drawer to
facilitate work

On the right page, Naruk desk in walnut finish.



Finishes

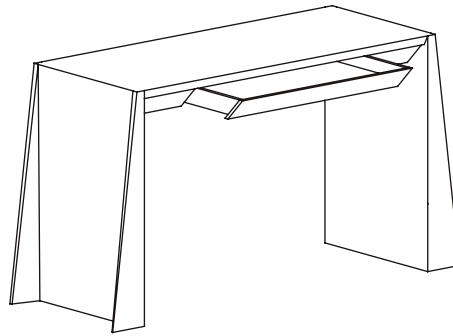

Laca, roble, nogal
Lacquer, oak, walnut

El cajón tiene un hueco útil de 65x32x4 cm
The drawer has space of 65x32x4 cm



Blanco
White



Piedra
Stone
RAL 7044



Arena
Sand
NCS S2005-Y20R



Visión
Taupe
NCS S4005-Y20R



Grafito
Graphite
RAL 7022



Pizarra
Slate
NCS S8500-N



Negro
Black



Niebla
Fog
NCS S5005-B20G



Océano
Ocean
NCS S7010 B10G



Menta
Mint
NCS S3010 G20Y



Oliva
Olive
NCS S6010 G10Y



Bosque
Forest
NCS S7010 B90G



Teja
Tile
NCS S5030 Y90R



Roble natural
Natural oak



Roble claro
Light oak



Nogal natural
Natural Walnut



Roble teñido ceniza
Ash stained oak



Roble teñido tostado
Toasted stained oak



Roble teñido wengue
Wengue stained oak



Roble negro
Black oak

Technical specifications

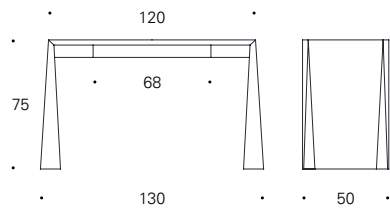

NP-35	130x50x75 cm
Nogal Walnut	
Roble Oak	
Laca Lacquer	



Naruk table

The Naruk table takes us to a different concept, creating a balance that evokes subtlety, character and simplicity. Its seemingly light set of inclined planes makes it blend in perfectly with its surroundings.







KEY IDEAS

The Naruk table, designed by Vicente Gallega, combines all the characteristics of the collection, offering a simple and minimalist solution for all types of environments.

This table perfectly synthesises the magnificent collection developed by the industrial designer Vicente Gallega. The Naruk table is the perfect summary of the play of inclinations and planes that can be glimpsed throughout the entire collection, giving it that unique touch of timeless, elegant and classic furniture that is a constant feature of this family.

Naruk table: Functionality, beauty and style.

NARUK OFFERS ELEGANCE IN ALL ITS SHAPES, SIZES AND FINISHES.





The coffee table features noble materials such as walnut, oak or lacquer to bring warmth to the space.

In this page, Naruk table in different finishes.

Finishes

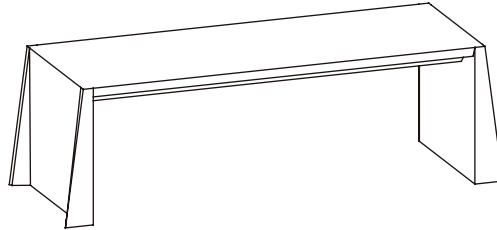

Laca, roble, nogal
Lacquer, oak, walnut



Blanco
White



Piedra
Stone
RAL 7044



Arena
Sand
NCS S2005-Y20R



Visión
Taupe
NCS S4005-Y20R



Grafito
Graphite
RAL 7022



Pizarra
Slate
NCS S8500-N



Negro
Black



Niebla
Fog
NCS S5005-B20G



Océano
Ocean
NCS S7010 B10G



Menta
Mint
NCS S3010 G20Y



Oliva
Olive
NCS S6010 G10Y



Bosque
Forest
NCS S7010 B90G



Teja
Tile
NCS S5030 Y90R



Roble natural
Natural oak



Roble claro
Light oak



Nogal natural
Natural Walnut



Roble teñido ceniza
Ash stained oak



Roble teñido tostado
Toasted stained oak



Roble teñido wengue
Wengue stained oak



Roble negro
Black oak

Technical specifications

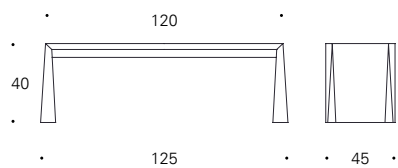

NZ-24

125x45x40 cm

Nogal
Walnut

Roble
Oak

Laca
Lacquer



LOTTA

Antoni Arola

The nobility of its materials and the purity of its design are the essence of the Lotta, a collection of tables capable of raising the level of any room. Its elegance and its formal structure allow the table to adapt to any environment.









*Lotta in residential ZODIAC in Illetes, Mallorca (Spain).
Project by Negre.*

*On these pages, Lotta on projects by Marga Comas
Interior Design in residential homes in Palma de
Mallorca (Spain).*









On this page, Lotta at Mallorcair, a project by Marga Comas at Mallorca Airport (Spain).

The design experience at a glance



*On this page, coffee table with black marble finish and
walnut legs.*



Le Touquet Golf Resort project in Le Touquet. Paris, Plage, (France).







LOTTA, SIMPLICITY AND VERSATILITY

Lotta is elegance transformed into design, its wide range of finishes and sizes allows it to be placed in all kinds of spaces, either as a coffee table or providing a subtle touch as a side table.



*On these pages, Lotta in the Hotel ME
Barcelona (Spain).
Project by Mur Arquitectura.*





On this page, bedside table with mink lacquer finish and structure in ash beech.



Finishes

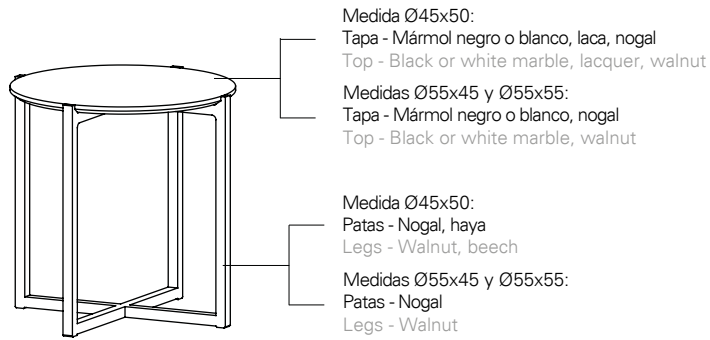

Blanco
White



Piedra
Stone

RAL 7044



Arena
Sand

NCS S2005-Y20R



Visión
Taupe

NCS S4005-Y20R



Grafito
Graphite

RAL 7022



Pizarra
Slate

NCS S8500-N



Negro
Black



Niebla
Fog

NCS S5005-B20G



Océano
Ocean

NCS S7010 B10G



Menta
Mint

NCS S3010 G20Y



Oliva
Olive

NCS S6010 G10Y



Bosque
Forest

NCS S7010 B90G



Teja
Tile

NCS S5030 Y90R



Haya natural
Natural beech



Nogal natural
Natural Walnut



Haya teñido ceniza
Ash stained beech



Haya teñido tostado
Toasted stained beech



Haya teñido wengue
Wengue stained beech



Haya negro
Black oak



Mármol blanco
White marble



Mármol negro
Black marble

LOTTA TIMELESSNESS AND SOPHISTICATION

Its unique design, created by Antoni Arola, together with the extreme quality of the materials and its handcrafted process give this collection the unique exclusivity of sophistication and the visual and aesthetic aspect of timelessness, offering the environment the perfect element to create a setting in which design in its purest state achieves the appropriate visual effect with its most integral presence.

On these pages, Lotta in white marble top and natural walnut legs.





Finishes

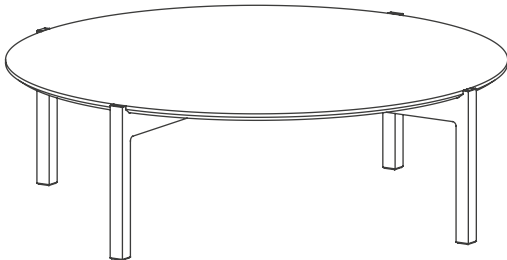

Tapa - Mármol negro o blanco
Top - Black or white marble

Estructura - Nogal
Structure - Walnut



Nogal natural
Natural Walnut



Mármol blanco
White marble



Mármol negro
Black marble



Technical specifications

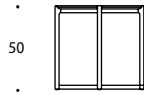

50



• ø 45 •

LOTTA-45R

Ø45x50 cm

Tapa mármol negro o blanco / Patas nogal

Black or white marble top / Walnut legs

Tapa nogal / Patas nogal

Walnut top / Walnut legs

Tapa laca / Patas nogal

Lacquered top / Walnut legs

Tapa mármol negro o blanco / Patas haya

Black or white marble top / Beech legs

Tapa laca / Patas haya

Lacquered top / Beech legs

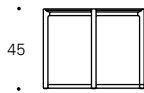

45

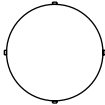

• ø 55 •

LOTTA-54R

Ø55x45 cm

Tapa mármol negro o blanco / Patas nogal

Black or white marble top / Walnut legs

Tapa nogal / Patas nogal

Walnut top / Walnut legs

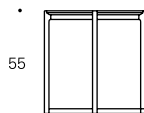

55



• ø 55 •

LOTTA-55R

Ø55x55 cm

Tapa mármol negro o blanco / Patas nogal

Black or white marble top / Walnut legs

Tapa nogal / Patas nogal

Walnut top / Walnut legs

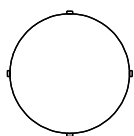
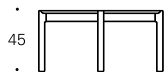

• ø 70 •

LOTTA-77R Ø70x45 cm

Tapa mármol negro o blanco / Patas nogal
Black or white marble top / Walnut legs

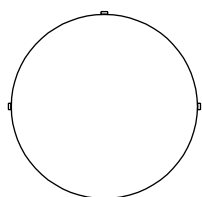
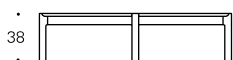

• ø 100 •

LOTTA-00R Ø100x38 cm

Tapa mármol negro o blanco / Patas nogal
Black or white marble top / Walnut legs

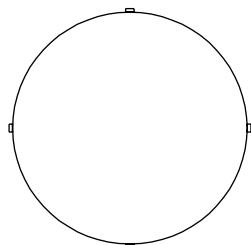
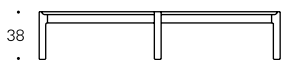

• ø 120 •

LOTTA-22R Ø120x38 cm

Tapa mármol negro o blanco / Patas nogal
Black or white marble top / Walnut legs

MIKA

Functionality

Yembarastudio



Collection of tables that stands out for its combination of materials and finishes on the tops to achieve unique pieces. The Mika table is a perfect balance between functionality and uniqueness, allowing it to adapt to numerous environments and architectural design spaces.





On this page, coffee table with tops in walnut and olive lacquer finish, black microtextured thermo-lacquered structure.



The option of creating customised sets with noble materials makes it possible to easily adapt to the needs of any project.

FUNCTIONALITY AND ADAPTABILITY

The side table is based on the design of its tubular metal structure, generating two heights and a visual play from different perspectives.









On this page, coffee table in mist lacquer and light oak and side table in ocean lacquer and light oak.





It offers a wide variety of materials and finishes on the tops such as walnut, oak and lacquer, which provides a great versatility to adapt the table to homes, hotels and offices.



Finishes

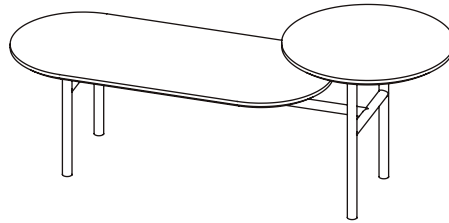

Tapa superior - Laca, roble, nogal
Superior top - Lacquer, oak, walnut

Tapa inferior - Laca, roble, nogal
Inferior top - Lacquer, oak, walnut

Estructura - Metal termolacado negro microtexturado
Structure - Micro-textured black thermo-lacquered metal



Blanco
White



Piedra
Stone
RAL 7044



Arena
Sand
NCS S2005-Y20R



Visión
Taupe
NCS S4005-Y20R



Grafito
Graphite
RAL 7022



Pizarra
Slate
NCS S8500-N



Negro
Black



Niebla
Fog
NCS S5005-B20G



Océano
Ocean
NCS S7010 B10G



Menta
Mint
NCS S3010 G20Y



Oliva
Olive
NCS S6010 G10Y



Bosque
Forest
NCS S7010 B90G



Teja
Tile
NCS S5030 Y90R



Roble natural
Natural oak



Roble claro
Light oak



Nogal natural
Natural Walnut



Roble teñido ceniza
Ash stained oak



Roble teñido tostado
Toasted stained oak



Roble teñido wengue
Wengue stained oak



Roble negro
Black oak









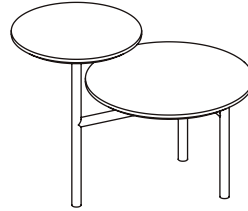









Finishes

Tapa superior - Laca, roble
 Superior top - Lacquer, oak

Tapa inferior - Laca, roble, nogal
 Inferior top - Lacquer, oak, walnut

Estructura - Metal termolacado negro microtexturado
 Structure - Micro-textured black thermo-lacquered metal



						
Blanco White	Piedra Stone RAL 7044	Arena Sand NCS S2005-Y20R	Visión Taupe NCS S4005-Y20R	Grafito Graphite RAL 7022	Pizarra Slate NCS S8500-N	Negro Black
						
Niebla Fog NCS S5005-B20G	Océano Ocean NCS S7010 B10G	Menta Mint NCS S3010 G20Y	Oliva Olive NCS S6010 G10Y	Bosque Forest NCS S7010 B90G	Teja Tile NCS S5030 Y90R	
						
Roble natural Natural oak	Roble claro Light oak	Nogal natural Natural Walnut	Roble teñido ceniza Ash stained oak	Roble teñido tostado Toasted stained oak	Roble teñido wengue Wengue stained oak	

Technical specifications

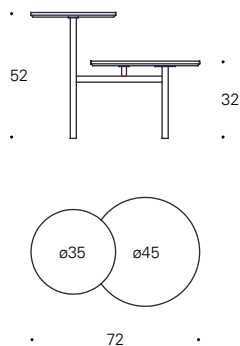

MIK-74

72x45x52 cm

Tapa inferior laca / Estructura termolacada negro microtexturado
Lacquer inferior top / Micro-textured black thermo-lacquered structure

Tapa inferior roble / Estructura termolacada negro microtexturado
Oak inferior top / Micro-textured black thermo-lacquered structure

Tapa inferior nogal / Estructura termolacada negro microtexturado
Walnut inferior top / Micro-textured black thermo-lacquered structure

Acabado tapa superior: Laca / Roble
Superior top finish: Lacquer / Oak

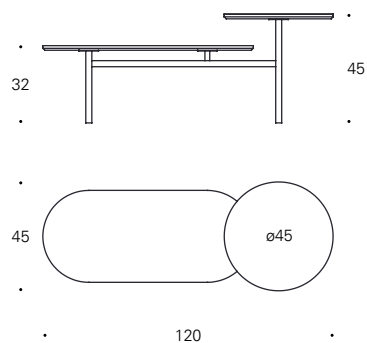

MIK-24

120x45x45 cm

Tapa inferior laca / Estructura termolacada negro microtexturado
Lacquer inferior top / Micro-textured black thermo-lacquered structure

Tapa inferior roble / Estructura termolacada negro microtexturado
Oak inferior top / Micro-textured black thermo-lacquered structure

Tapa inferior nogal / Estructura termolacada negro microtexturado
Walnut inferior top / Micro-textured black thermo-lacquered structure

Acabado tapa superior: Laca / Roble / Nogal
Superior top finish: Lacquer / Oak / Walnut

ANT

Francesc Rifé



Its elegance and uniqueness together with the nobility of its materials place this collection at the highest level of our products. Due to its versatility, it fits both in the living room and in large rooms of the contract sector.



*On these pages, Ant at Dubai Internet City HQ, Dubai (UAE).
Project by The Total Office.*



ANT, BALANCE.

Ant is a versatile table, suitable for numerous contexts and environments, always providing the distinction and elegance that characterise it, blending in with its surroundings while offering personality, design and balance.



Ant, distinction and elegance

The interplay of the marble with the structure of the table and the metal profile creates an unforgettable aesthetic appeal that expresses the quality and sobriety of a unique design. In addition, the flying effect of the top gives it the sensation of lightness and harmony that is exclusive to a work that is destined to play a leading role in any environment.



Metal profile in brass finish.



Variety of finishes on the structure.



Fully customisable.

On these pages, Ant with white marble top.









On this page, ANT table, in a project by Rubio & Ros, for a residential building in Valencia (Spain).

VARIETY IN COMPOSITIONS

It has a wide variety of finishes that allow it to be customised to the user's taste. Its marble tops together with the metal profile finished in brass and the immense variety of lacquers for the structure offer numerous options for all areas.



Finishes

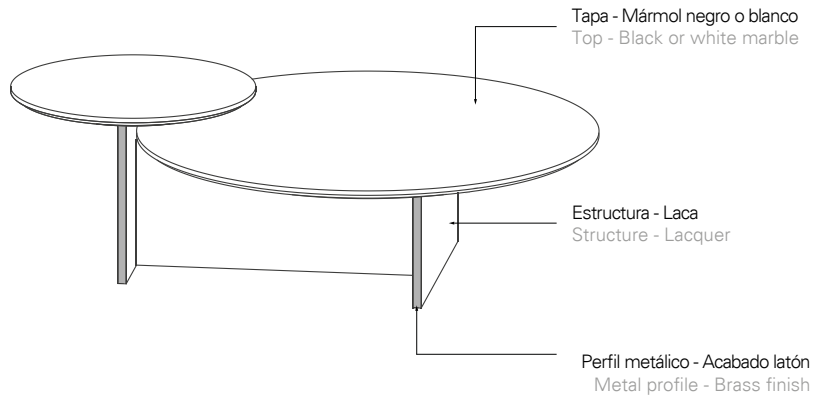

Blanco
White



Piedra
Stone

RAL 7044



Arena
Sand

NCS S2005-Y20R



Visión
Taupe

NCS S4005-Y20R



Grafito
Graphite

RAL 7022



Pizarra
Slate

NCS S8500-N



Negro
Black



Niebla
Fog

NCS S5005-B20G



Océano
Ocean

NCS S7010 B10G



Menta
Mint

NCS S3010 G20Y



Oliva
Olive

NCS S6010 G10Y



Bosque
Forest

NCS S7010 B90G



Teja
Tile

NCS S5030 Y90R



Mármol blanco
White marble



Mármol negro
Black marble

Technical specifications

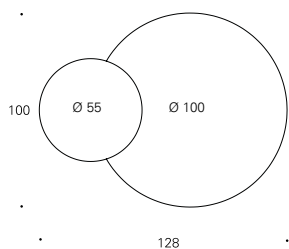

ANT-20

128x100x40 cm

Tapa mármol blanco o negro / Estructura laca / Perfil metálico acabado latón
 Black o white marble top / Lacquer structure / Brass finish metal profile

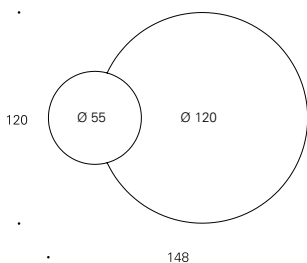

ANT-42

148x120x40 cm

Tapa mármol blanco o negro / Estructura laca / Perfil metálico acabado latón
 Black o white marble top / Lacquer structure / Brass finish metal profile

ANT LITE

Francesc Rifé

The Ant Lite coffee table, an extension of the Ant collection, stands out for its balance between delicacy and uniqueness. Thanks to the architecture of its base and the refinement of the marble top, it is a table that brings elegance to the room.











Ant Lite,
sobriety,
elegance,
delicacy.



Ant Lite is a coffee table with a circular top in white or black marble. A practical and distinguished solution for a special interior design.

Ant and Ant Lite,
elegance in essence.

Ant Lite Ø 100 cm

Top: White marble

Structure: Ocean



Ant Ø 100 cm

Top: White marble

Structure: Taupe



Ant Lite Ø 120 cm

Top: Black marble

Structure: Graphite

The Ant and Ant Lite collections are the perfect example of a unique, elegant and timeless table. The wide variety of finishes offers endless possibilities to fully customise the design and adjust it to the surroundings. The metal profile of the structure perfectly marks the distinction and good taste in a table that raises the level of the environment with its mere presence. Whether in the original Ant format or in the classic and sober simplicity of Ant Lite, these collections are destined to add unique value and make the environment a unique and exclusive setting.

Ant Ø 100 cm

Top: Black marble

Structure: Forest



Ant Lite Ø 100 cm

Top: White marble

Structure: Stone

On this page Ant and Ant Lite in some of their finishes and sizes.

Finishes

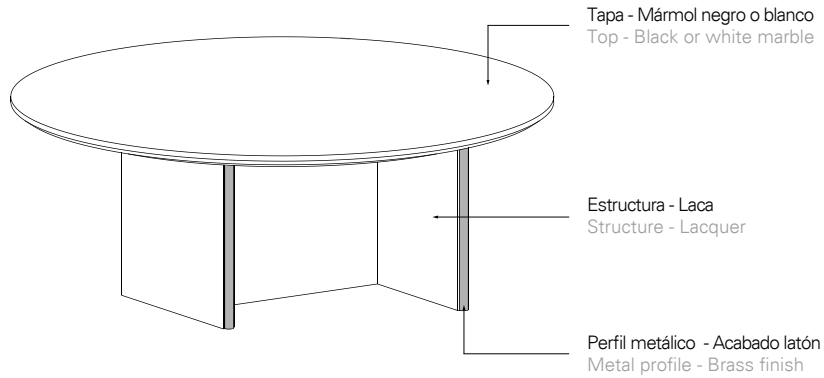

Blanco
White



Piedra
Stone

RAL 7044



Arena
Sand

NCS S2005-Y20R



Visión
Taupe

NCS S4005-Y20R



Grafito
Graphite

RAL 7022



Pizarra
Slate

NCS S8500-N



Negro
Black



Niebla
Fog

NCS S5005-B20G



Océano
Ocean

NCS S7010 B10G



Menta
Mint

NCS S3010 G20Y



Oliva
Olive

NCS S6010 G10Y



Bosque
Forest

NCS S7010 B90G



Teja
Tile

NCS S5030 Y90R



Mármol blanco
White marble



Mármol negro
Black marble

Technical specifications

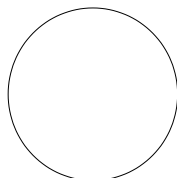

• Ø100 •

ANT-03

Ø100x38 cm

Tapa mármol negro o blanco / Estructura laca / Perfil metálico acabado latón
Black or white marble top / Lacquer structure / Brass finish metal profile

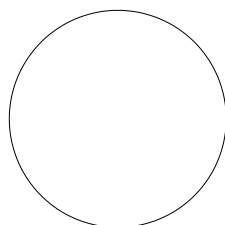

• Ø120 •

ANT-23

Ø120x38 cm

Tapa mármol negro o blanco / Estructura laca / Perfil metálico acabado latón
Black or white marble top / Lacquer structure / Brass finish metal profile

VILLA

Envelope

OrtegaGuijarro



The Villa collection generates a different visual play transmitting an elegance that raises the level of any space. Villa is born with an aesthetic balance through shapes, achieving a particular beauty.

The enveloping shape of its legs and its poetic transparency make it a design that generates a unique visual effect that fills any room with originality and good taste.



On this page, coffee table with top in transparent glass finish and structure in microtextured black thermo-lacquered metal.





The essence of the Villa coffee table is its metallic structure in black thermo-lacquered lacquer, stripes that intertwine between its legs giving the sensation of wanting to embrace each one of them.

The Villa collection is elegance and aesthetic balance. It offers a wide variety of finishes so you can personalise it to your taste.





On this page, coffee table with top in glass finish and side table with top in grey smoked glass finish, structure in black thermo-lacquered metal microtextured on both.

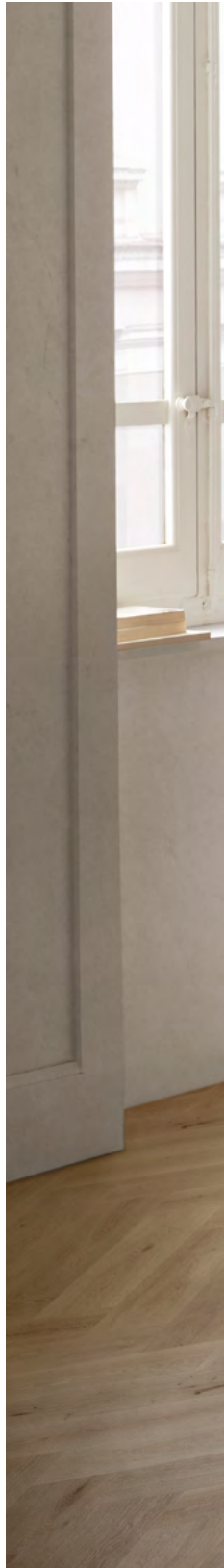









Finishes

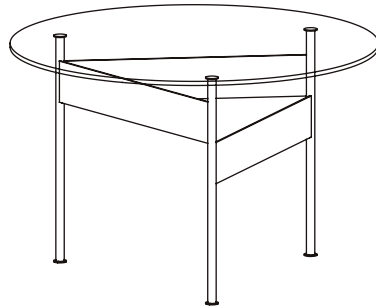

Tapa - Cristal transparente, cristal fumé gris templado
Top - Transparent glass, smoked grey tempered glass

Estructura - Metal termolacado negro microtexturado
Structure - Micro-textured black thermo-lacquered metal



Cristal fumé gris
Smoked grey glass



Cristal Transparente
Transparent glass



Technical specifications

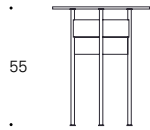

VIL-45

Ø45x55 cm

Tapa cristal transparente / Estructura termolacada negro microtexturado
Transparent glass top / Micro-textured black thermo-lacquered structure

Tapa cristal fumé gris / Estructura termolacada negro microtexturado
Smoked grey glass top / Micro-textured black thermo-lacquered structure

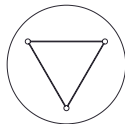
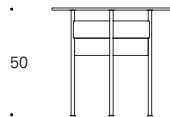

VIL-55

Ø55x50 cm

Tapa cristal transparente / Estructura termolacada negro microtexturado
Transparent glass top / Micro-textured black thermo-lacquered structure

Tapa cristal fumé gris / Estructura termolacada negro microtexturado
Smoked grey glass top / Micro-textured black thermo-lacquered structure

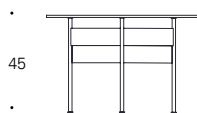

45

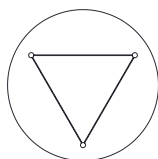

Ø70

VIL-74

Ø70x45 cm

Tapa cristal transparente / Estructura termolacada negro microtexturado
 Transparent glass top / Micro-textured black thermo-lacquered structure

Tapa cristal fumé gris / Estructura termolacada negro microtexturado
 Smoked grey glass top / Micro-textured black thermo-lacquered structure

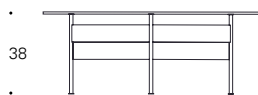

38

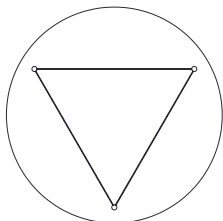

Ø100

VIL-03

Ø100x38 cm

Tapa cristal transparente / Estructura termolacada negro microtexturado
 Transparent glass top / Micro-textured black thermo-lacquered structure

Tapa cristal fumé gris / Estructura termolacada negro microtexturado
 Smoked grey glass top / Micro-textured black thermo-lacquered structure

PLAT

Antoni Arola

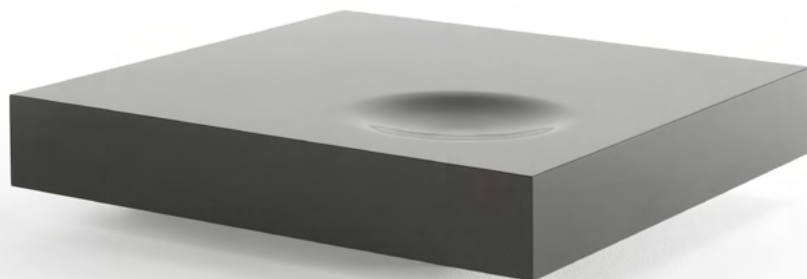

It is a collection of tables in which a subtle circular imprint on the top acts as a counterpoint between its predominantly straight lines. It has an extractable drawer in one of its laterals and castors in its bottom part.





*Locke At Broken Wharf, Londres (Reino Unido)
Project by Clippings.*





Plat coffee table in graphite lacquer finish.

INTEGRATION AND PRACTICALITY

The table is made of lacquered MDF and includes a side pull-out drawer and castors, which can optionally be replaced by a plinth. The height of the table can be modified. The Plat coffee table brings a note of sympathy and coherence to any space. It is a piece that integrates easily in homes, offices and hotels.

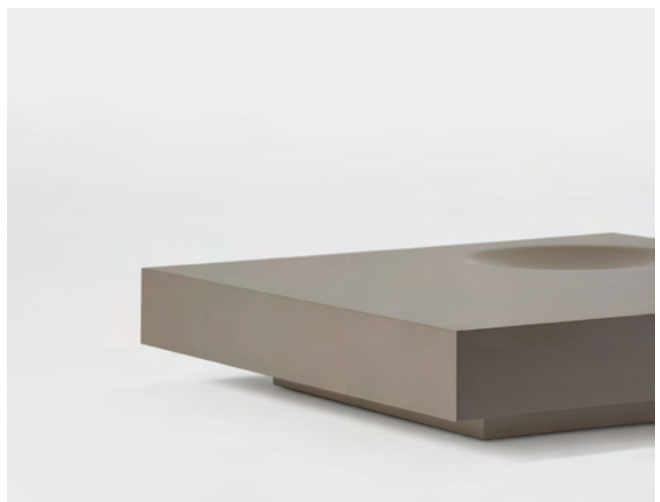

PLAT

On the right page, Plat coffee table in graphite finish in Costa de la Calma, Mallorca (Spain), project by Marga Comas Interior Design.

INDIVIDUALLY OR IN COMBINATION

Plat offers the possibility of displaying all its elegance individually as well as in combination playing with the different finishes available as well as the different sizes presented. Plat is the perfect coffee table, individually or in combination.

*En this page, coffee table and side table Plat in mink and white lacquer finish at CASA_DCOLORES in Marratxi, Mallorca (Spain).
Project by rimirim design.*





Finishes

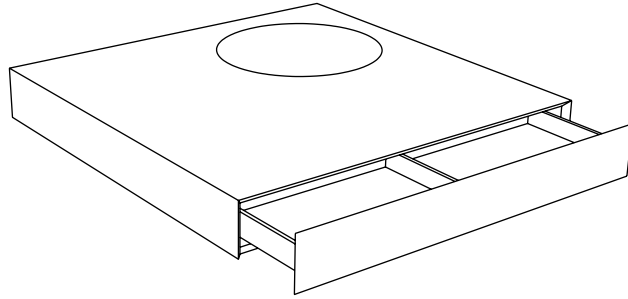

Cajón
Drawer



Blanco
White



Piedra
Stone

RAL 7044



Arena
Sand

NCS S2005-Y20R



Visión
Taupe

NCS S4005-Y20R



Grafito
Graphite

RAL 7022



Pizarra
Slate

NCS S8500-N



Negro
Black



Niebla
Fog

NCS S5005-B20G



Océano
Ocean

NCS S7010 B10G



Menta
Mint

NCS S3010 G20Y



Oliva
Olive

NCS S6010 G10Y



Bosque
Forest

NCS S7010 B90G



Teja
Tile

NCS S5030 Y90R

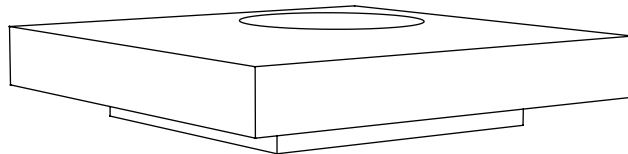

Opción zócalo*
Base option*

Technical specifications

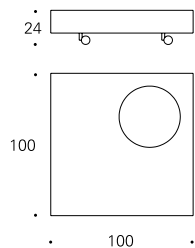

PLAT-00 100x100x24 cm

Laca
Lacquer

Opción zócalo*
Base option*

Opción altura 29 cm con ruedas más altas o zócalo*
29 cm height option with higher castors or base*

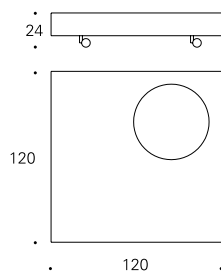

PLAT-22 120x120x24 cm

Laca
Lacquer

Opción zócalo*
Base option*

Opción altura 29 cm con ruedas más altas o zócalo*
29 cm height option with higher castors or base*

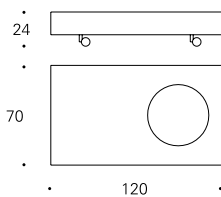

PLAT-27 120x70x24 cm

Laca
Lacquer

Opción zócalo*
Base option*

Opción altura 29 cm con ruedas más altas o zócalo*
29 cm height option with higher castors or base*

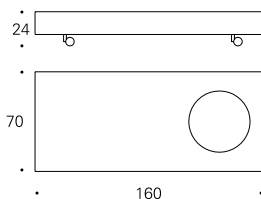

PLAT-67 160x70x24 cm

Laca
Lacquer

Opción zócalo*
Base option*

Opción altura 29 cm con ruedas más altas o zócalo*
29 cm height option with higher castors or base*

YOHSI

Discoh Design



It stands out for its enormous versatility, capable of adapting to any space and lifestyle. The multiple combinations of materials make it possible to create a table for every type of environment.







*Ecole 42 School, Abu Dhabi (United Arab Emirates).
Project by The Total Office.*



YOSHI: THE VERSATILITY SOLUTION

The Yoshi collection is undoubtedly one of the most versatile and functional collections as it adapts perfectly to all types of environments, blending in with its surroundings and adding a personal and elegant touch. Selected in numerous projects all over the world, Yoshi has become an essential for interior designers with different styles who have discovered the essential value of this table in their spaces.

*On the left, Yoshi at the Hotel Meliá Jardines del Teide in Tenerife (Spain)
Project by GPY Arquitectos.
On the right, Yoshi at the Hotel Tigotan Lovers & Friends Playa de las
Americas in Tenerife (Spain).*



*Coffee table with milk lacquer finish and black
microtextured structure.*





Different sizes,
same design.

FINISHES AND MEASUREMENTS

The tables can be customised in lacquer, walnut, oak, grey smoked mirror, bronze smoked mirror, black glass or statuary ceramic and the metal legs can be in thermo-lacquered black lacquer, lacquer in other colours, chrome or brass. Yohsi provides all kinds of options, with its finishes and different sizes that make it a versatile and original piece. The customisation of this design is total, thus giving a touch of good taste that gives the extreme functionality an aesthetic and elegant formality.



*Yohsi in Casa Öttel in Barrika, (Spain)
Project by IN56.*



YOHSI, CUSTOMISABLE AND ADAPTABLE

The unique legs of the Yohsi table, as well as the effect of its finishes are the perfect combination in terms of product customisation and total adaptation to projects. Yohsi is a unique design, spread all over the world in numerous rooms of all kinds, always providing an aesthetic point wherever it makes its presence felt.

*Yohsi at UBS ICD Office, Dubai (UAE).
Project by The Total Office.*







*On the right, Yohsi at LinkedIn's office in Madrid (Spain).
On the left, Yohsi at the National Bank of Bahrain. Human Space project.*



Finishes

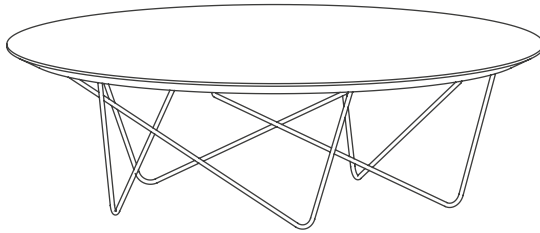

Tapa - Laca, espejo gris o bronce, nogal, roble, cristal negro, cerámica statuario
 Top - Lacquer, grey or bronze mirror, walnut, oak, black glass, statuario ceramic

Patas - Metal termolacado negro microtexturado, Opción en cromo, acabado latón, laca*
 Legs - Micro-textured black thermo-lacquered metal. Option in chrome, brass finish, lacquer*



Blanco
White



Piedra
Stone

RAL 7044



Arena
Sand

NCS S2005-Y20R



Visión
Taupe

NCS S4005-Y20R



Grafito
Graphite

RAL 7022



Pizarra
Slate

NCS S8500-N



Negro
Black



Niebla
Fog

NCS S5005-B20G



Océano
Ocean

NCS S7010 B10G



Menta
Mint

NCS S3010 G20Y



Oliva
Olive

NCS S6010 G10Y



Bosque
Forest

NCS S7010 B90G



Teja
Tile

NCS S5030 Y90R



Roble natural
Natural oak



Roble claro
Light oak



Nogal natural
Natural Walnut



Roble teñido ceniza
Ash stained oak



Roble teñido tostado
Toasted stained oak



Roble teñido wengue
Wengue stained oak



Roble negro
Black oak



Cerámica Statuario
Statuario Ceramic



Espejo fumé gris
Smoked grey mirror



Espejo fumé bronce
Smoked bronze mirror



Cristal negro
Black glass



Technical specifications

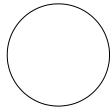

• Ø55 •

YOSH-55

Ø55x52 cm

Tapa laca / Patas termolacadas negro microtexturado
Lacquer top / Micro-textured black thermo-lacquered legs

Tapa nogal / Patas termolacadas negro microtexturado
Walnut top / Micro-textured black thermo-lacquered legs

Tapa roble / Patas termolacadas negro microtexturado
Oak top / Micro-textured black thermo-lacquered legs

Tapa cristal negro / Patas termolacadas negro microtexturado
Black glass top / Micro-textured black thermo-lacquered legs

Tapa espejo fumé gris o bronce / Patas termolacadas negro microtexturado
Smoked grey or bronze mirror top / Micro-textured black thermo-lacquered legs

Tapa cerámica statuario / Patas termolacadas negro microtexturado
Statuario ceramic top / Micro-textured black thermo-lacquered legs

Opción patas lacadas*
Lacquer legs option*

Opción patas cromadas*
Chromed legs option*

Opción patas acabado latón*
Brass finish legs option*

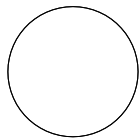

• Ø70 •

YOSH-74

Ø70x45 cm

Tapa laca / Patas termolacadas negro microtexturado
Lacquer top / Micro-textured black thermo-lacquered legs

Tapa nogal / Patas termolacadas negro microtexturado
Walnut top / Micro-textured black thermo-lacquered legs

Tapa roble / Patas termolacadas negro microtexturado
Oak top / Micro-textured black thermo-lacquered legs

Tapa cristal negro / Patas termolacadas negro microtexturado
Black glass top / Micro-textured black thermo-lacquered legs

Tapa espejo fumé gris o bronce / Patas termolacadas negro microtexturado
Smoked grey or bronze mirror top / Micro-textured black thermo-lacquered legs

Tapa cerámica statuario / Patas termolacadas negro microtexturado
Statuario ceramic top / Micro-textured black thermo-lacquered legs

Opción patas lacadas*
Lacquer legs option*

Opción patas cromadas*
Chromed legs option*

Opción patas acabado latón*
Brass finish legs option*

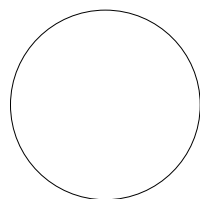
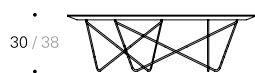

• Ø100 •

YOSH-03

Ø100x30 / 38 cm

Tapa laca / Patas termolacadas negro microtexturado
Lacquer top / Micro-textured black thermo-lacquered legs

Tapa nogal / Patas termolacadas negro microtexturado
Walnut top / Micro-textured black thermo-lacquered legs

Tapa roble / Patas termolacadas negro microtexturado
Oak top / Micro-textured black thermo-lacquered legs

Tapa cristal negro / Patas termolacadas negro microtexturado
Black glass top / Micro-textured black thermo-lacquered legs

Tapa espejo fumé gris o bronce / Patas termolacadas negro microtexturado
Smoked grey or bronze mirror top / Micro-textured black thermo-lacquered legs

Tapa cerámica statuario / Patas termolacadas negro microtexturado
Statuario ceramic top / Micro-textured black thermo-lacquered legs

Opción patas lacadas*
Lacquer legs option*

Opción patas cromadas*
Chromed legs option*

Opción patas acabado latón*
Brass finish legs option*

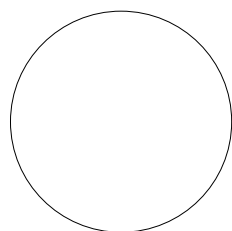

• Ø120 •

YOSH-23

Ø120x30 / 38 cm

Tapa laca / Patas termolacadas negro microtexturado
Lacquer top / Micro-textured black thermo-lacquered legs

Tapa nogal / Patas termolacadas negro microtexturado
Walnut top / Micro-textured black thermo-lacquered legs

Tapa roble / Patas termolacadas negro microtexturado
Oak top / Micro-textured black thermo-lacquered legs

Opción patas lacadas*
Lacquer legs option*

Opción patas cromadas*
Chromed legs option*

Opción patas acabado latón*
Brass finish legs option*

YOHSI ELLIPTICAL

Discoh Design



Yohsi Elliptical is a collection of coffee tables, composed of an elliptical top supported by a lattice of curved metal rods that are the essence of the piece.



*Coffee table with graphite lacquer finish
and black microtextured structure.*



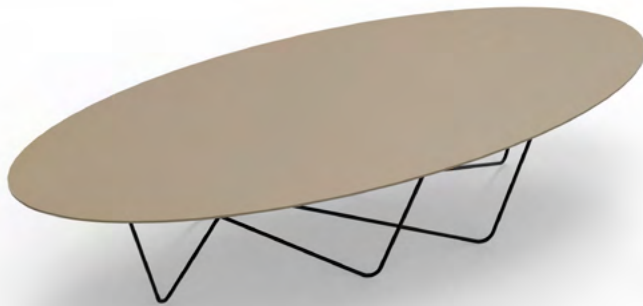

● Taupe

Yohsi elliptical is an extension of the Yohsi collection, with the same set of legs and the same adaptability and versatility in terms of finishes. Its original elliptical shape gives it the ability to be placed in central spaces providing dynamism as well as balance to the environment.

Available in two sizes, Yohsi elliptical is the perfect example of customisable design furniture that takes the environment to another level. Its shape, its legs, make Yohsi elliptical the perfect piece for all types of contract spaces, from hotels and offices to residential and restaurants.

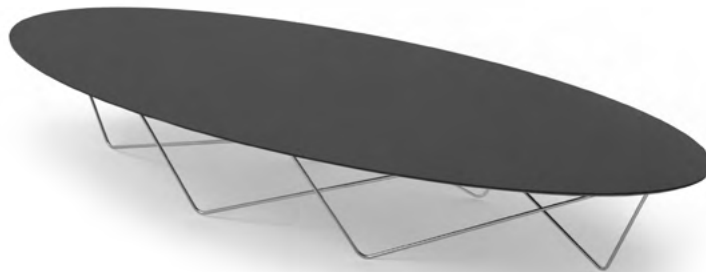

● Black

Yohsi and Yohsi elliptical,
versatility in essence.

Yohsi Ø 120 cm

Top: Ash oak.
Structure: Microtextured black.



Yohsi Ø 55 cm

Top: White Lacquer
Structure: White micro-textured white



YOHSI AND YOHSI ELLIPTICAL

Yohsi and Yohsi elliptical are two expressions of the same design concept. The slenderness of the legs generates a unique visual effect of lightness and dynamism that at the same time maintains an intrinsic authentic touch of elegance and originality, transmitting the same essence in all its versions.

Its different sizes, as well as the immense variety in terms of finishes, make Yohsi the ideal collection for both combination and individual use. That is why our Yohsi collection is an indispensable part of numerous projects of all kinds both nationally and internationally.

Yohsi elliptical 180 x 60 cm

Top: Light oak

Structure: Black microtextured black



Yohsi Ø 100 cm

Top: Black lacquer

Structure: Black microtextured black



On this page Yohsi and Yohsi elliptical in some of its finishes and sizes.

Finishes

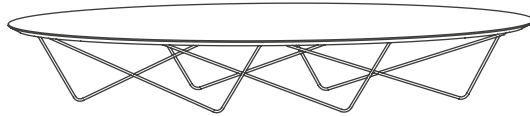

Tapa - Laca, espejo gris, nogal, roble
 Top - Lacquer, grey mirror, walnut, oak

Patas - Metal termolacado negro microtexturado
 Opción cromo, latón, laca*
 Legs - Black thermo-lacquered micro-textured metal
 Option in chrome, brass, lacquer*



Blanco
White



Piedra
Stone

RAL 7044



Arena
Sand

NCS S2005-Y20R



Visión
Taupe

NCS S4005-Y20R



Grafito
Graphite

RAL 7022



Pizarra
Slate

NCS S8500-N



Negro
Black



Niebla
Fog

NCS S5005-B20G



Océano
Ocean

NCS S7010 B10G



Menta
Mint

NCS S3010 G20Y



Oliva
Olive

NCS S6010 G10Y



Bosque
Forest

NCS S7010 B90G



Teja
Tile

NCS S5030 Y90R



Roble natural
Natural oak



Roble claro
Light oak



Nogal natural
Natural Walnut



Roble teñido ceniza
Ash stained oak



Roble teñido tostado
Toasted stained oak



Roble teñido wengue
Wengue stained oak



Roble negro
Black oak



Espejo fumé gris
Smoked grey mirror



Cristal negro
Black glass

Technical specifications

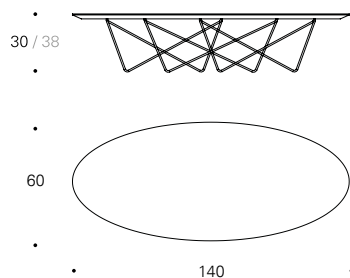

YOSH-46

140x60x30 / 38 cm

Tapa laca / Patas termolacadas negro microtexturado
Lacquer top / Micro-textured black thermo-lacquered legs

Tapa roble / Patas termolacadas negro microtexturado
Oak top / Micro-textured black thermo-lacquered legs

Tapa nogal / Patas termolacadas negro microtexturado
Walnut top / Micro-textured black thermo-lacquered legs

Tapa espejo fumé gris o bronce / Patas termolacadas negro microtexturado
Smoked grey or bronze mirror top / Micro-textured black thermo-lacquered legs

Opción patas lacadas*
Lacquer legs option*

Opción patas cromadas*
Chromed legs option*

Opción patas acabado latón*
Brass finish legs option*

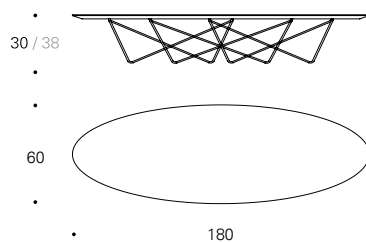

YOSH-86

180x60x30 / 38 cm

Tapa laca / Patas termolacadas negro microtexturado
Lacquer top / Micro-textured black thermo-lacquered legs

Tapa espejo fumé gris o bronce / Patas termolacadas negro microtexturado
Smoked grey or bronze mirror top / Micro-textured black thermo-lacquered legs

Opción patas lacadas*
Lacquer legs option*

Opción patas cromadas*
Chromed legs option*

Opción patas acabado latón*
Brass finish legs option*

TEMPS

Vicente Gallega



The Temps collection stands out for its soft, continuous and insinuating shapes that create an elegant, timeless piece with personality. It has been worked with noble materials such as solid beech wood and marble, providing craftsmanship in the elaboration of the piece.









On this page, coffee table with black marble finish and ash stained beech structure.





The table is composed of a marble top and a structure in beech wood. A very functional solution that brings great warmth to projects.

SOPHISTICATION AND WARMTH

Due to its characteristics in terms of design, variety of finishes and sizes, it is a very versatile piece. Its rectangular top version is ideal to be placed in central spaces where it can provide all its warmth and sophistication, offering a different touch with its reminiscence to the past within the design.



On this page, Temps coffee table with white marble top and natural beech structure.







- Black marble
- Natural beech

Temps combines different materials and finishes to offer different design solutions. Creating unique spaces that allow the table to take on a special, stylish and essential role.

It is a reminiscence of the past within design. Its characteristics in terms of design and measurements create a very versatile piece.



- White marble
- Toasted stained beech

Finishes

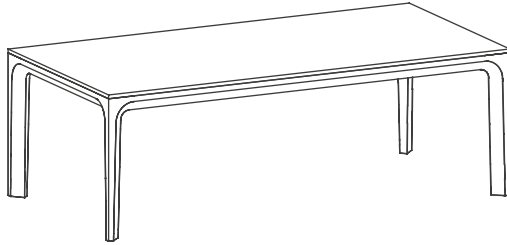

Tapa - Mármol negro o blanco
Top - Black or white marble

Patas - Haya
Legs - Beech



Haya natural
Natural beech



Haya teñido ceniza
Ash stained beech



Haya teñido tostado
Toasted stained beech



Haya teñido wengue
Wengue stained beech



Haya negro
Black oak



Mármol blanco
White marble



Mármol negro
Black marble

Technical specifications

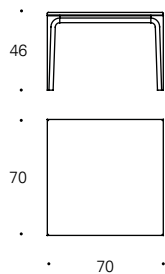

TEMPS-77

70x70x46 cm

Tapa mármol negro o blanco / Estructura haya
Black or white marble top / Beech structure

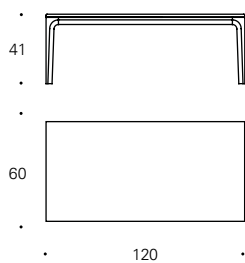

TEMPS-26

120x60x41 cm

Tapa mármol negro o blanco / Estructura haya
Black or white marble top / Beech structure



REFLEX

Discoh Design



The Reflex collection proposes a visual play between two geometries. Its volumes and planes allow perfect adaptation and mimicry with a wide range of environments.





On this page, Reflex with top in light oak finish and structure in white thermo-lacquered metal.





*On this page, Reflex in Photographic Studio in Valencia, (Spain).
Project by Rubio & Ros.*

Materials such as lacquer, walnut, compact slate, statuario ceramic and oak achieve great harmony with each other and, at the same time, raise the level of the space. The structure is available in white or micro-textured black.







*Reflex table in Safagrell Ibiza, in Sant Lorenç,
Mallorca (Spain).
Project by Espai 31.*





*Versatility, elegance and variety
in all sizes.*



Finishes

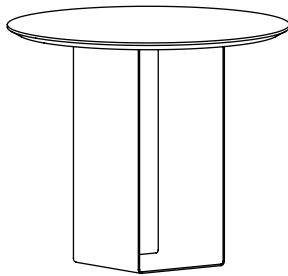

Tapa - Laca, roble, nogal, compacto pizarra, cerámica statuario
 Top - Lacquer, oak, walnut, slate compact, statuario ceramic

Estructura - Metal termolacado blanco o negro microtexturado
 Structure - Micro-textured black or white thermo-lacquered metal



Blanco
White



Piedra
Stone

RAL 7044



Arena
Sand

NCS S2005-Y20R



Visión
Taupe

NCS S4005-Y20R



Grafito
Graphite

RAL 7022



Pizarra
Slate

NCS S8500-N



Negro
Black



Niebla
Fog

NCS S5005-B20G



Océano
Ocean

NCS S7010 B10G



Menta
Mint

NCS S3010 G20Y



Oliva
Olive

NCS S6010 G10Y



Bosque
Forest

NCS S7010 B90G



Teja
Tile

NCS S5030 Y90R



Roble natural
Natural oak



Roble claro
Light oak



Nogal natural
Natural Walnut



Roble teñido ceniza
Ash stained oak



Roble teñido tostado
Toasted stained oak



Roble teñido wengue
Wengue stained oak



Roble negro
Black oak



Cerámica Statuario
Statuario Ceramic



Compacto pizarra
Slate compact

Technical specifications

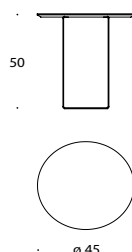

REFLEX-45R

Ø45x50 cm

Tapa laca / Estructura termolacada blanco o negro microtexturado
Lacquer top / Micro-textured black or white thermo-lacquered structure

Tapa roble / Estructura termolacada blanco o negro microtexturado
Oak top / Micro-textured black or white thermo-lacquered structure

Tapa nogal / Estructura termolacada blanco o negro microtexturado
Walnut top / Micro-textured black or white thermo-lacquered structure

Tapa compacto pizarra / Estructura termolacada blanco o negro microtexturado
Slate compact top / Micro-textured black or white thermo-lacquered structure

Tapa cerámica statuario / Estructura termolacada blanco o negro microtexturado
Statuario ceramic top / Micro-textured black or white thermo-lacquered structure

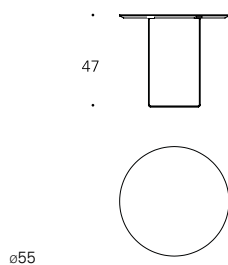

REFLEX-54R

Ø55x47 cm

Tapa laca / Estructura termolacada blanco o negro microtexturado
Lacquer top / Micro-textured black or white thermo-lacquered structure

Tapa roble / Estructura termolacada blanco o negro microtexturado
Oak top / Micro-textured black or white thermo-lacquered structure

Tapa nogal / Estructura termolacada blanco o negro microtexturado
Walnut top / Micro-textured black or white thermo-lacquered structure

Tapa compacto pizarra / Estructura termolacada blanco o negro microtexturado
Slate compact top / Micro-textured black or white thermo-lacquered structure

Tapa cerámica statuario / Estructura termolacada blanco o negro microtexturado
Statuario ceramic top / Micro-textured black or white thermo-lacquered structure

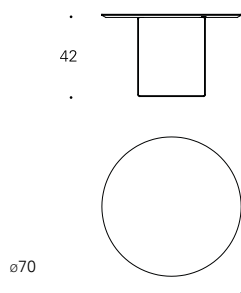

REFLEX-74R

Ø70x42 cm

Tapa laca / Estructura termolacada blanco o negro microtexturado
Lacquer top / Micro-textured black or white thermo-lacquered structure

Tapa roble / Estructura termolacada blanco o negro microtexturado
Oak top / Micro-textured black or white thermo-lacquered structure

Tapa nogal / Estructura termolacada blanco o negro microtexturado
Walnut top / Micro-textured black or white thermo-lacquered structure

Tapa compacto pizarra / Estructura termolacada blanco o negro microtexturado
Slate compact top / Micro-textured black or white thermo-lacquered structure

Tapa cerámica statuario / Estructura termolacada blanco o negro microtexturado
Statuario ceramic top / Micro-textured black or white thermo-lacquered structure

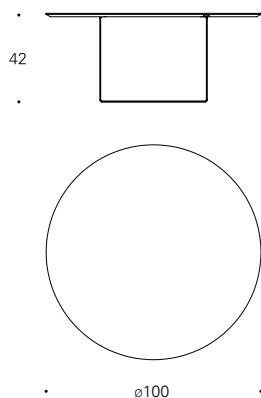
**REFLEX-04R**

Ø100x42 cm

Tapa laca / Estructura termolacada blanco o negro microtexturado

Lacquer top / Micro-textured black or white thermo-lacquered structure

Tapa roble / Estructura termolacada blanco o negro microtexturado

Oak top / Micro-textured black or white thermo-lacquered structure

Tapa nogal / Estructura termolacada blanco o negro microtexturado

Walnut top / Micro-textured black or white thermo-lacquered structure

Tapa compacto pizarra / Estructura termolacada blanco o negro microtexturado

Slate compact top / Micro-textured black or white thermo-lacquered structure

Tapa cerámica statuario / Estructura termolacada blanco o negro microtexturado

Statuario ceramic top / Micro-textured black or white thermo-lacquered structure



VAN

Francesc Rifé



The Van collection stands out for its great woodwork. The solid wood structure gives it the necessary solidity and transmits the warmth of its materials. Easily accepted both in the home and in contract installations.





In these pages, Van side table with black ceramic top and walnut legs. Van side table with black ceramic top and walnut legs.





*Van in Ricard Camarena Restaurant in Valencia (Spain).
Project by Francesc Rifé.*

Elegance and design

It is a collection that, thanks to its size, provides numerous possibilities to create different and unique spaces.

Thanks to the combinations of colours and materials, it is a piece that fits perfectly with decorative environments.



ORIGINALITY AND VERSATILITY.

Van is the perfect combination of classicism and originality, being able to adapt perfectly to spaces of different styles and tastes. It can be combined thanks to its different sizes and also works individually. This collection provides numerous possible options to make any type of space a dynamic and pleasant place.

*Van at LinkedIn's offices in Dubai (UAE).
Jalapeno project.*







*On this page Van at the Saddle Club,
Melbourne (Australia)
Sweedesign project.*



With extreme care in the treatment of materials, the solid structure brings simplicity and solidity to an adaptable table.

KENDO

Van en Can Rafalet, Ibiza (España).



The variety of sizes and its own versatility make Van a table that works together and on its own.



Finishes

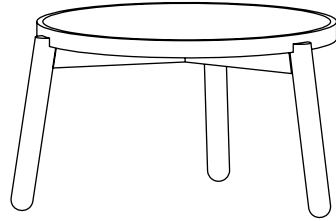

Tapa - Cerámica / Nogal / Haya
Top - Ceramic / Walnut / Beech

Estructura - Nogal / Haya
Structure - Walnut / Beech



Haya natural
Natural beech



Nogal natural
Natural Walnut



Haya teñido ceniza
Ash stained beech



Haya teñido tostado
Toasted stained beech



Haya teñido wengue
Wengue stained beech



Haya negro
Black oak



Cerámica negro
Black Ceramic

Technical specifications

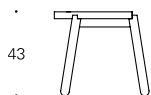

43

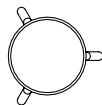

ø40

VAN-40R

Ø40x43 cm

Tapa cerámica negra / Patas haya
Black ceramic top / Beech legs

Tapa cerámica negra / Patas nogal
Black ceramic top / Walnut legs

Tapa haya / Patas haya
Beech top / Beech legs

Tapa nogal / Patas nogal
Walnut top / Walnut legs

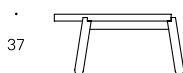

37

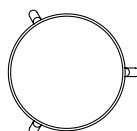

ø60

VAN-60R

Ø60x 37 cm

Tapa cerámica negra / Patas haya
Black ceramic top / Beech legs

Tapa cerámica negra / Patas nogal
Black ceramic top / Walnut legs

Tapa haya / Patas haya
Beech top / Beech legs

Tapa nogal / Patas nogal
Walnut top / Walnut legs

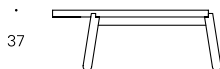

37

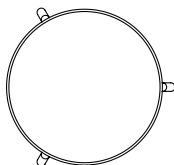

ø80

VAN-80R

Ø80x37 cm

Tapa cerámica negra / Patas haya
Black ceramic top / Beech legs

Tapa cerámica negra / Patas nogal
Black ceramic top / Walnut legs

TRAZO

PerezOchando



Visual lightness, personality and strength are the characteristics of the Trazo table, a perfect table that brings freshness and modernity to home or contract spaces, adapting through its neutrality to any decorative style of its surroundings.











Trazo is a table with apparently simple lines that reveal a very suggestive game through the encounters between the top and its legs.



MÉS QUE DISSENY STUDIO



Trazo is a versatile proposal that offers a game of elegance and simplicity in any room.

Finishes

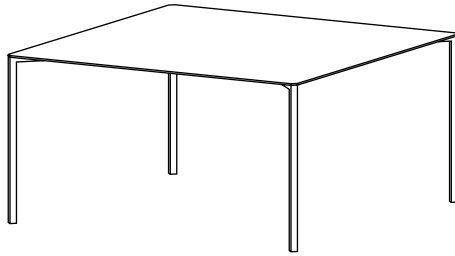

Blanco
White



Piedra
Stone
RAL 7044



Arena
Sand
NCS S2005-Y20R



Visión
Taupe
NCS S4005-Y20R



Grafito
Graphite
RAL 7022



Pizarra
Slate
NCS S8500-N



Negro
Black



Niebla
Fog
NCS S5005-B20G



Océano
Ocean
NCS S7010 B10G



Menta
Mint
NCS S3010 G20Y



Oliva
Olive
NCS S6010 G10Y



Bosque
Forest
NCS S7010 B90G



Teja
Tile
NCS S5030 Y90R

Technical specifications

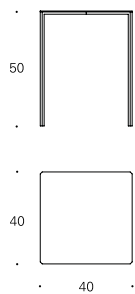

TRAZO-44

40x40x50 cm

Termolacado negro microtexturado
Micro-textured black thermo-lacquered

Laca
Lacquer

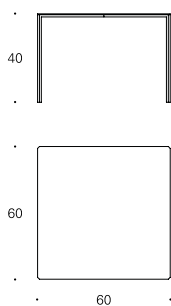

TRAZO-66

60x60x40 cm

Termolacado negro microtexturado
Micro-textured black thermo-lacquered

Laca
Lacquer



VERA

Serafín Redondo



Vera is a coffee table with a characteristic volume, where it is possible to combine the lacquer of its exterior finish with different finishes in the interior recesses.







*Vera at the Mirador de Valencia, Valencia
(Spain).
Project by Vicente Navarro.*



The Vera coffee table brings elegance and coherence to any space. It is a piece that integrates easily both at home and in offices and hotels.







**VERA, MIMICRY.**

Vera is the perfect example of adaptable furniture that blends in with its surroundings. Perfect for large spaces where you can develop all your faculties to the maximum, this coffee table occupies a necessary volume to give meaning to the environment that surrounds it. In addition to its elegance and sobriety, it adds a touch of functionality with its interior openings.

*Vera in residential project Palma de Mallorca (Spain).
Project by Negre.*

Finishes

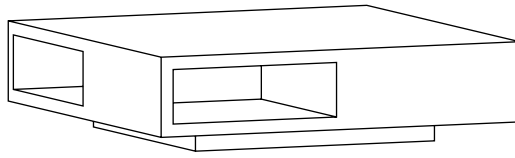

Huecos interiores - Roble, nogal, laca
Interior holes - Oak, walnut, lacquer

Cuerpo y zócalo - Laca
Body and base - Lacquer



Blanco
White



Piedra
Stone
RAL 7044



Arena
Sand
NCS S2005-Y20R



Visón
Taupe
NCS S4005-Y20R



Grafito
Graphite
RAL 7022



Pizarra
Slate
NCS S8500-N



Negro
Black



Niebla
Fog
NCS S5005-B20G



Océano
Ocean
NCS S7010 B10G



Menta
Mint
NCS S3010 G20Y



Oliva
Olive
NCS S6010 G10Y



Bosque
Forest
NCS S7010 B90G



Teja
Tile
NCS S5030 Y90R



Roble natural
Natural oak



Roble claro
Light oak



Nogal natural
Natural Walnut



Roble teñido ceniza
Ash stained oak



Roble teñido wengue
Wengue stained oak



Roble negro
Black oak

Technical specifications

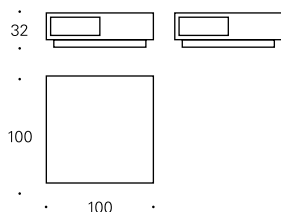

VZ-00 100x100x32 cm

Cuerpo y zócalo laca / Huecos interiores roble
Lacquer body and base / Oak interior holes

Cuerpo y zócalo laca / Huecos interiores nogal
Lacquer body and base / Walnut interior holes

Cuerpo y zócalo laca / Huecos interiores laca
Lacquer body and base / Lacquer interior holes

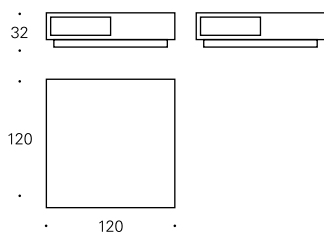

VZ-22 120x120x32 cm

Cuerpo y zócalo laca / Huecos interiores roble
Lacquer body and base / Oak interior holes

Cuerpo y zócalo laca / Huecos interiores nogal
Lacquer body and base / Walnut interior holes

Cuerpo y zócalo laca / Huecos interiores laca
Lacquer body and base / Lacquer interior holes

MARÍA

Transparency

Miguel Milá



The work in every detail represents the stamp of its author, excellence and timelessness. Miguel Milá, a pioneer of 1950s design in Spain, has collaborated with Kendo in the re-edition of María.

The table is characterised by its lightness and transparency. Not only does it allow a full view of what is underneath, but it is also capable of highlighting and framing it.





On these pages, Maria, with her enveloping play of transparencies.

Lightness
Transparency
Design.





ELEGANCE AND TIMELESSNESS

María gives style in her concept. Miguel Milá's design produces a visual effect that transforms the environment and mimics the piece with its surroundings.





Finishes

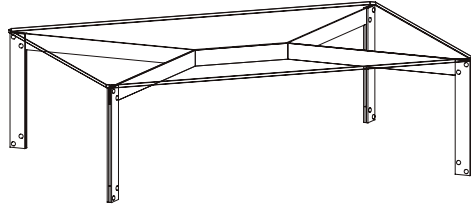

Estructura - Metal termolacado negro microtexturado
Structure - Micro-textured black thermo-lacquered metal

Tapa - Cristal transparente
Top - Transparent glass

Patas - Metal cromado
Legs - Chromed metal



Cristal templado transparente
Transparent tempered glass



Technical specifications

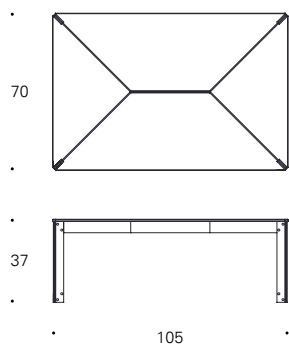

MAR-07 105x70x37 cm

Tapa cristal transparente / Patas metálicas cromadas
Transparent glass top / Chromed metal legs

Acabado estructura: termolacada negro microtexturado
Structure finish: Micro-textured black thermo-lacquered

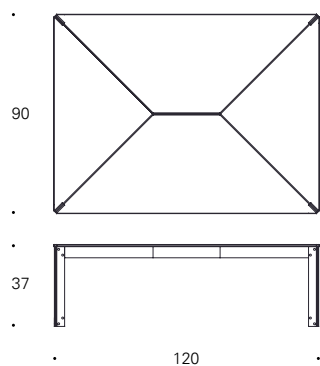

MAR-29 120x90x37 cm

Tapa cristal transparente / Patas metálicas cromadas
Transparent glass top / Chromed metal legs

Acabado estructura: termolacada negro microtexturado
Structure finish: Micro-textured black thermo-lacquered

GREY

Francesc Rifé



A collection of consoles whose grey or smoked bronze mirror gives them a distinguished and elegant air that brings spaciousness and dynamism to any room, always offering practicality and good taste.











FUNCTIONAL MINIMALISM

Grey is a minimalist, practical console mirror that makes a difference. It offers the possibility of integrating an indirect light led luminaire in the lower base of its drawer, adding warmth and functionality to the design. The Grey console is available in two versions depending on the size of the back panel and the position of the drawer, to adapt to all types of interiors. Its play of straight planes as well as the reflection of the mirror give it unique characteristics that make it an original piece that is at the same time simply elegant. Grey follows the line of technical, original and customisable design that allows it to adapt to numerous environments and spaces.

Among the many possibilities offered by Grey, there is the option of integrating LED lights in the bottom base of the drawer.





Finishes

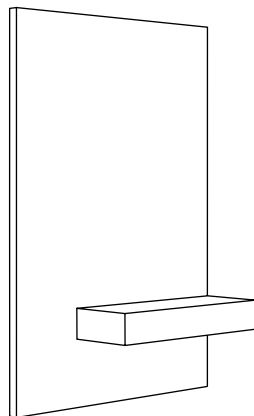

Blanco
White



Piedra
Stone

RAL 7044



Arena
Sand

NCS S2005-Y20R



Visión
Taupe

NCS S4005-Y20R



Grafito
Graphite

RAL 7022



Pizarra
Slate

NCS S8500-N



Negro
Black



Niebla
Fog

NCS S5005-B20G



Océano
Ocean

NCS S7010 B10G



Menta
Mint

NCS S3010 G20Y



Oliva
Olive

NCS S6010 G10Y



Bosque
Forest

NCS S7010 B90G



Teja
Tile

NCS S5030 Y90R



Espejo fumé gris
Smoked grey mirror



Espejo fumé bronce
Smoked bronze mirror

Technical specifications

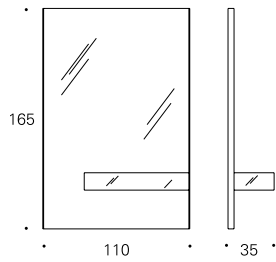

GREY-13 110x35x165 cm

Laca y espejo fumé gris o bronce
Lacquer and smoked grey or bronze mirror

Opción luz cajón*
Drawer light option*

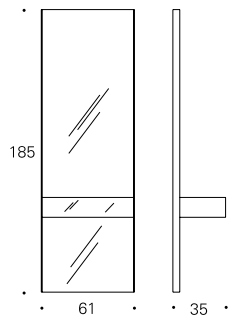

GREY-638 61x35x185 cm

Laca y espejo fumé gris o bronce
Lacquer and smoked grey or bronze mirror

Opción luz cajón*
Drawer light option*

CLIK

Mario Ruiz



Clik is a collection of coffee and side tables for use in contract and residential spaces. The collection stands out for having a metal structure that acts as a link between the base and the top, achieving an original and balanced solution.









CLIK, a Universe

CLIK: POSSIBILITIES

The Clik collection is the perfect example of the variety of good design. Its elegant design allows the finishes of the top, base of the top, structure and base to be fully customised, allowing the user to perfectly adjust the table so that it blends in perfectly with its surroundings. Clik is a veritable universe of design possibilities.

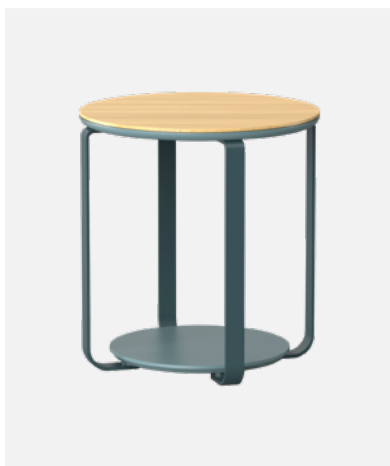

On the left page, Clik table in black glass finish on the top and black lacquer on the base of the top, structure and tops.

CLIK LITE Ø 50 cm

Top: Sand
Base of the top structure: Ocean



CLIK Ø 70 x 40 cm

Top: Natural oak
Base of the top and structure: Stone
Base: Graphite

A COLLECTION, A FAMILY

Clik is a family of tables composed of different models, the essence of this collection is the interplay between the top and the base of the top that permits creating all types of variations and compositions to suit the user's taste, generating immense possibilities. Its slender legs house a magazine rack that brings greater aesthetics and practicality to the collection, which finds its extension in the Clik Lite, a lighter version that reveals the perfect union of the structure in the centre, creating a magnificent visual effect that brings elegance to the environment.

***CLIK Ø 100***

Top: ash oak
Base of the top, structure and base:
Taupe

***CLIK Ø 50 cm***

Top: Light oak
Base of the top and base: Forest
Structure: Olive

Finishes

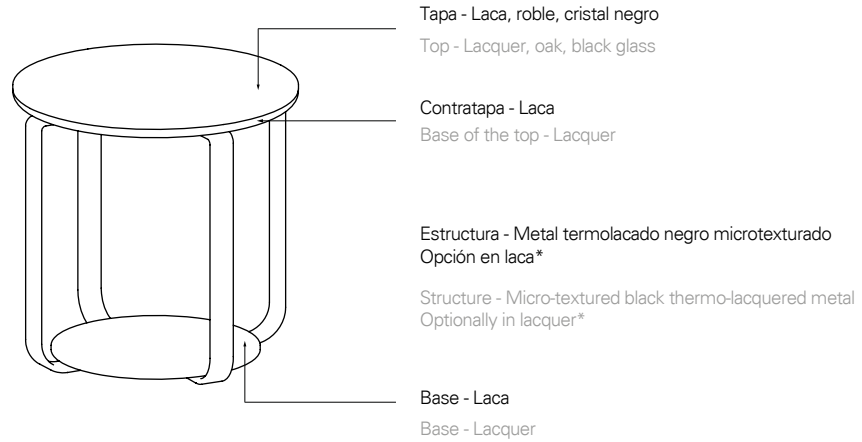

Blanco
White



Piedra
Stone
RAL 7044



Arena
Sand
NCS S2005-Y20R



Visión
Taupe
NCS S4005-Y20R



Grafito
Graphite
RAL 7022



Pizarra
Slate
NCS S8500-N



Negro
Black



Niebla
Fog
NCS S5005-B20G



Océano
Ocean
NCS S7010 B10G



Menta
Mint
NCS S3010 G20Y



Oliva
Olive
NCS S6010 G10Y



Bosque
Forest
NCS S7010 B90G



Teja
Tile
NCS S5030 Y90R



Roble natural
Natural oak



Roble claro
Light oak



Roble teñido ceniza
Ash stained oak



Roble teñido tostado
Toasted stained oak



Roble teñido wengue
Wengue stained oak



Roble negro
Black oak



Cristal negro
Black glass

Technical specifications

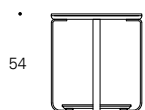

54

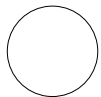

• Ø50 •

CLIK-55RB

Ø50x54 cm

Tapa laca / Estructura termolacada negro microtexturado
Lacquer top / Micro-textured black thermo-lacquered structure

Tapa roble / Estructura termolacada negro microtexturado
Oak top / Micro-textured black thermo-lacquered structure

Acabado base: Laca
Base finish: Lacquer

Opción estructura laca* La base tapa se lacará en el mismo color de la estructura.
Lacquer structure option* Lacquer top base is in the same colour as the structure.

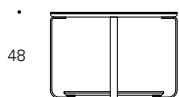

48

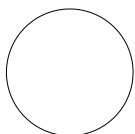

• Ø70 •

CLIK-77RB

Ø70x48 cm

Tapa laca / Estructura termolacada negro microtexturado
Lacquer top / Micro-textured black thermo-lacquered structure

Tapa roble / Estructura termolacada negro microtexturado
Oak top / Micro-textured black thermo-lacquered structure

Tapa cristal negro / Estructura termolacada negro microtexturado
Black glass top / Micro-textured black thermo-lacquered structure

Acabado base: Laca
Base finish: Lacquer

Opción estructura laca* La base tapa se lacará en el mismo color de la estructura.
Lacquer structure option* Lacquer top base is in the same colour as the structure.

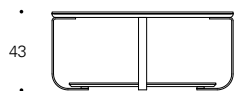

43

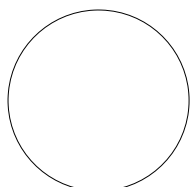

• Ø100 •

CLIK-00RB

Ø100x43 cm

Tapa laca / Estructura termolacada negro microtexturado
Lacquer top / Micro-textured black thermo-lacquered structure

Tapa roble / Estructura termolacada negro microtexturado
Oak top / Micro-textured black thermo-lacquered structure

Tapa cristal negro / Estructura termolacada negro microtexturado
Black glass top / Micro-textured black thermo-lacquered structure

Acabado base: Laca
Base finish: Lacquer

Opción estructura laca* La base tapa se lacará en el mismo color de la estructura.
Lacquer structure option* Lacquer top base is in the same colour as the structure.

CLIK LITE

Mario Ruiz



Clik Lite is a collection of coffee and side tables for use in contract and residential spaces. The collection stands out for its original and balanced structure that allows it to adapt easily to any environment.











The Klik Lite collection is subtle in every detail. The top is available in different materials such as oak veneer, black glass and MDF lacquered in all colours. The metal structure with four legs connected in a cross shape marks its identity together with the different pieces that compose it.





CLIK LITE, DESIGN AND MIMICRY

Clik Lite is the perfect choice when it comes to transmitting the purest values of design, as its adaptation to the environment makes it a unique and indispensable element that undoubtedly gives a feeling of harmony, tranquillity and calm. The wide variety of finishes allows total personalisation of the table to the designed space. The shape of its legs as well as the subtle support of the top generate a unique effect of simplicity, elegance and lightness that allows to play with other constituent elements of the environment to give a timeless touch to the room.

On these pages, Clik Lite in black glass top, black lacquered base of the top and black microtextured thermo-lacquered structure.

Finishes

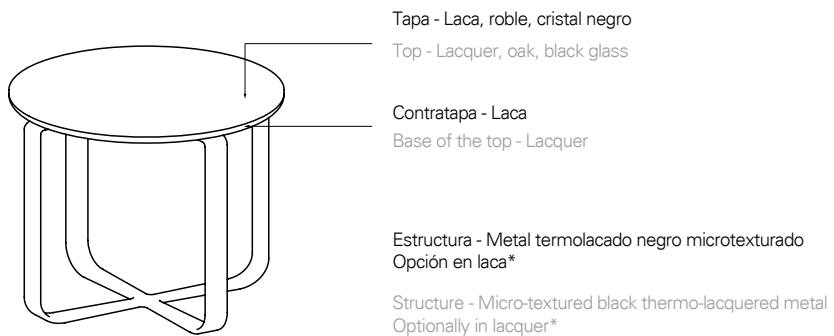

Blanco
White



Piedra
Stone
RAL 7044



Arena
Sand
NCS S2005-Y20R



Visión
Taupe
NCS S4005-Y20R



Grafito
Graphite
RAL 7022



Pizarra
Slate
NCS S8500-N



Negro
Black



Niebla
Fog
NCS S5005-B20G



Océano
Ocean
NCS S7010 B10G



Menta
Mint
NCS S3010 G20Y



Oliva
Olive
NCS S6010 G10Y



Bosque
Forest
NCS S7010 B90G



Teja
Tile
NCS S5030 Y90R



Roble natural
Natural oak



Roble claro
Light oak



Roble teñido ceniza
Ash stained oak



Roble teñido tostado
Toasted stained oak



Roble teñido wengue
Wengue stained oak



Roble negro
Black oak



Cristal negro
Black glass

Technical specifications

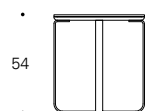

54



• Ø50 •

CLIK-55RC

Ø50x54 cm

Tapa laca / Estructura termolacada negro microtexturado
Lacquer top / Micro-textured black thermo-lacquered structure

Tapa roble / Estructura termolacada negro microtexturado
Oak top / Micro-textured black thermo-lacquered structure

Opción estructura laca* La base tapa se lacará en el mismo color de la estructura.
Lacquer structure option* Lacquer top base is in the same colour as the structure.

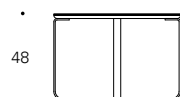

48

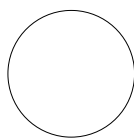

• Ø70 •

CLIK-77RC

Ø70x48 cm

Tapa laca / Estructura termolacada negro microtexturado
Lacquer top / Micro-textured black thermo-lacquered structure

Tapa roble / Estructura termolacada negro microtexturado
Oak top / Micro-textured black thermo-lacquered structure

Tapa cristal negro / Estructura termolacada negro microtexturado
Black glass top / Micro-textured black thermo-lacquered structure

Opción estructura laca* La base tapa se lacará en el mismo color de la estructura.
Lacquer structure option* Lacquer top base is in the same colour as the structure.

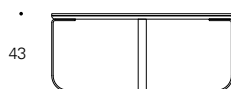

43

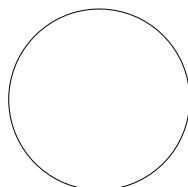

• Ø100 •

CLIK-00RC

Ø100x43 cm

Tapa laca / Estructura termolacada negro microtexturado
Lacquer top / Micro-textured black thermo-lacquered structure

Tapa roble / Estructura termolacada negro microtexturado
Oak top / Micro-textured black thermo-lacquered structure

Tapa cristal negro / Estructura termolacada negro microtexturado
Black glass top / Micro-textured black thermo-lacquered structure

Opción estructura laca* La base tapa se lacará en el mismo color de la estructura.
Lacquer structure option* Lacquer top base is in the same colour as the structure.

AXIL

Serafín Redondo



Axil has become a reference piece in our trajectory. It surprises by its marked volume and the exquisite craftsmanship of the details in its construction. With its variety of finishes and elegant design, it is an indispensable piece for any space.





● Natural oak

Axil is a very practical and original solution, with a drawer integrated in the lower part of the unit to facilitate the storage of elements inside. Thanks to the naturalness of its finishes, it brings warmth to the room.



*On this page Axil console in ash
oak finish*



Finishes

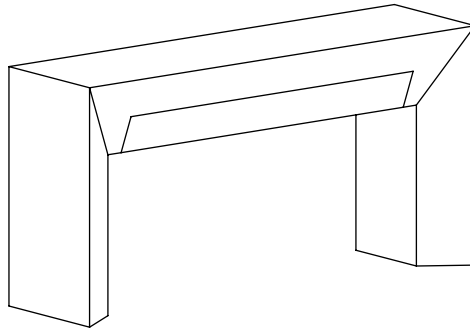

Blanco
White



Piedra
Stone
RAL 7044



Arena
Sand
NCS S2005-Y20R



Visión
Taupe
NCS S4005-Y20R



Grafito
Graphite
RAL 7022



Pizarra
Slate
NCS S8500-N



Negro
Black



Niebla
Fog
NCS S5005-B20G



Océano
Ocean
NCS S7010 B10G



Menta
Mint
NCS S3010 G20Y



Oliva
Olive
NCS S6010 G10Y



Bosque
Forest
NCS S7010 B90G



Teja
Tile
NCS S5030 Y90R



Roble natural
Natural oak



Roble claro
Light oak



Roble teñido ceniza
Ash stained oak



Roble teñido tostado
Toasted stained oak



Roble teñido wengue
Wengue stained oak



Roble negro
Black oak

Technical specifications

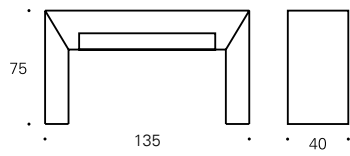

XY-34 135x40x75 cm

Roble
Oak

Laca
Lacquer

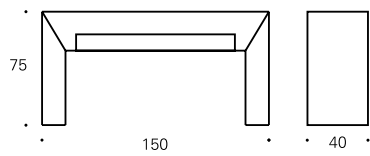

XY-54 150x40x75 cm

Roble
Oak

Laca
Lacquer



TRIA

PerezOchando



Because of its uniqueness, the Tria table has become an iconic piece in our collection. Its careful design together with the wide range of colours of its finish make the table a unique object that will make us fall in love with its freshness and style.





Tria, the simplicity of good design.

Tria is a table with apparently simple lines, but with a very interesting visual play thanks to the cavity formed by joining the three metal plates creating an original triangular silhouette that gives shape to the table.



*Lightweight,
original
different*

Its original design generates the visual effect of the legs being an extension of the table top itself, turning its silhouette into a unique piece that also offers numerous possibilities thanks to its large number of finishes and the combination with other tables, both the same and different.

On the next page Tria in tile lacquer finish.



Finishes

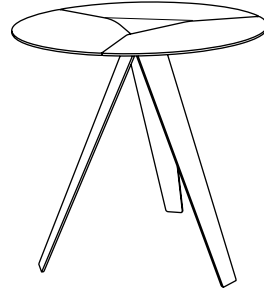

Blanco
White



Piedra
Stone
RAL 7044



Arena
Sand
NCS S2005-Y20R



Visión
Taupe
NCS S4005-Y20R



Grafito
Graphite
RAL 7022



Pizarra
Slate
NCS S8500-N



Negro
Black



Niebla
Fog
NCS S5005-B20G



Océano
Ocean
NCS S7010 B10G



Menta
Mint
NCS S3010 G20Y



Oliva
Olive
NCS S6010 G10Y



Bosque
Forest
NCS S7010 B90G



Teja
Tile
NCS S5030 Y90R

Technical specifications

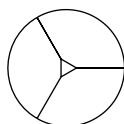
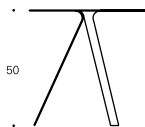

• Ø 50 •

TRIA-55R

Ø50x50 cm

Termolacado negro o blanco microtexturado
Micro-textured black or white thermo-lacquered

Laca
Lacquer

MADERA | WOOD



Haya natural
Natural beech



Haya teñido ceniza
Ash stained beech



Haya teñido tostado
Tosted stained beech



Haya teñido wengue
Wengue stained beech



Haya negro
Black haya



Roble natural
Natural oak



Roble claro
Light oak



Roble negro
Black oak

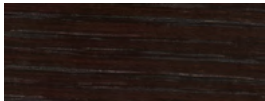

Roble teñido wengue
Wengue stained oak

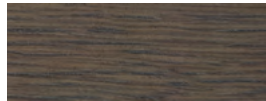

Roble teñido ceniza
Ash stained oak

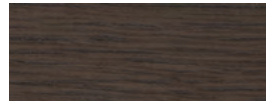

Roble teñido tostado
Toasted stained oak



Nogal natural
Natural walnut

CRISTAL | GLASS



Cristal negro
Black glass

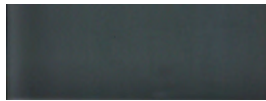

Cristal fumé gris
Smoked grey glass



Cristal transparente
Transparent glass

ESPEJO | MIRROR



Espejo fumé gris
Smoked grey mirror



Espejo fumé bronce
Smoked bronze mirror

MÁRMOL | MARBLE



Mármol blanco
White marble



Mármol negro
Black marble

CERÁMICA STATUARIO | STATUARIO CERAMIC



Cerámica statuario
Statuario ceramic

COMPACTO | COMPACT

Compacto pizarra
Slate compact

CERÁMICA (Colección VAN) | CERAMIC (VAN collection)

Negro
Black

LACA MATE | MATT LACQUER

Piedra
Stone
—
RAL 7044



Arena
Sand
—
NCS S2005-Y20R



Visón
Taupe
—
NCS S4005-Y20R



Grafito
Graphite
—
RAL 7022



Niebla
Fog
—
NCS S5005-B20G



Océano
Ocean
—
NCS S7010 B10G



Pizarra
Slate
—
NCS S8500-N



Negro
Black
—



Menta
Mint
—
NCS S3010 G20Y



Oliva
Olive
—
NCS S6010 G10Y



Bosque
Forest
—
NCS S7010-B90G

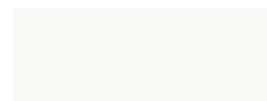

Blanco
White
—



Teja
Tile
—
NCS S5030 Y90R

Opcionalmente se pueden solicitar otros colores de laca referenciados según la carta RAL o carta NCS.

Alternatively you can request other colours of lacquer referenced according to RAL or NCS card.

Los colores de nuestras muestras de acabados son indicativos, por lo que pueden existir ligeras diferencias entre las muestras y la mercancía entregada.

The sample colours finishes are indicative, so there may be slight differences between the samples and the goods delivered.

kendo

Kendo mobiliario, s.l.

Gibraltar, 8
46930 Quart de Poblet
Valencia (Spain)
(T) +34 96 153 03 30

comercial@kendomobiliario.com
export@kendomobiliario.com
www.kendomobiliario.com



