

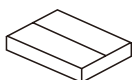

20 min



x1



x1



x1



A x 2

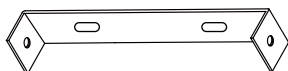

B x 1



D x 1



C x 2



E x 2

OFF

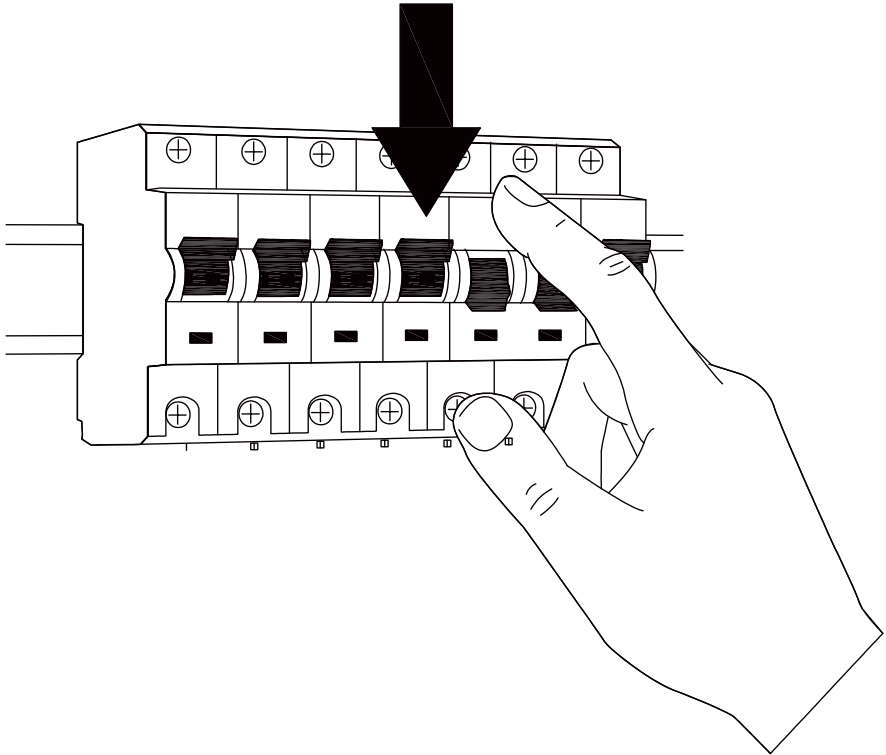

1

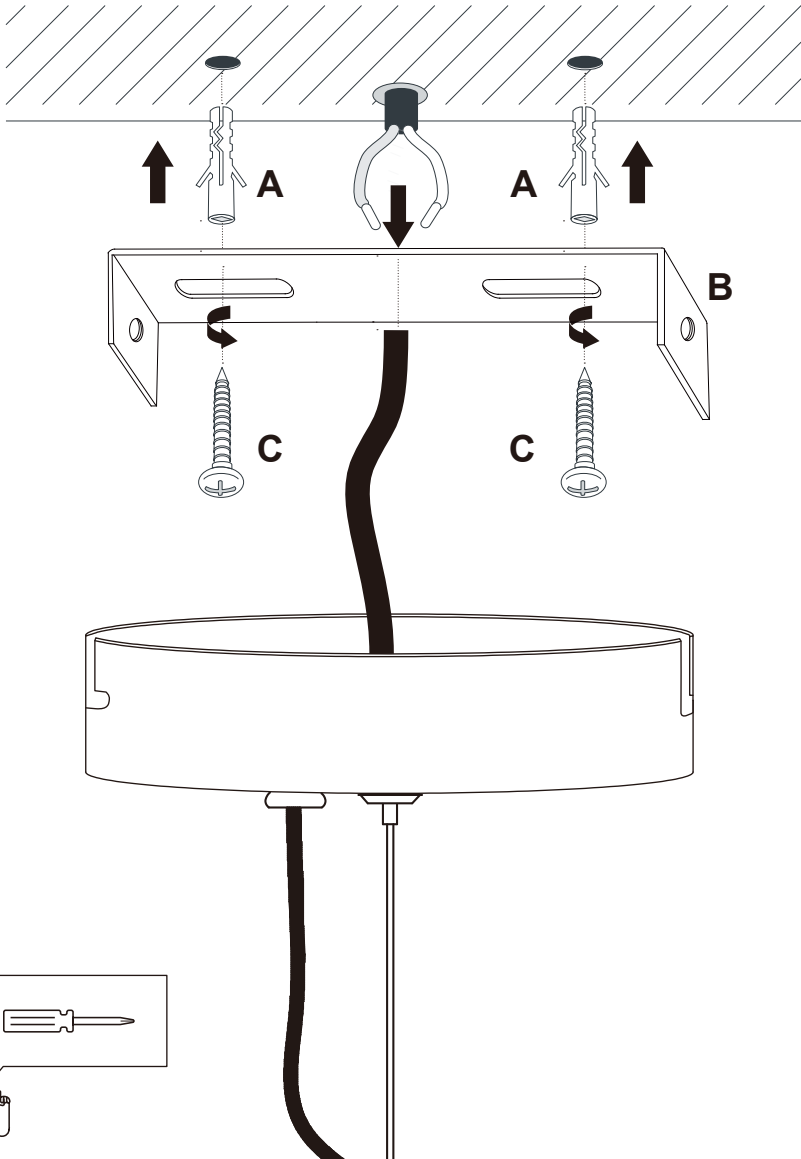

2

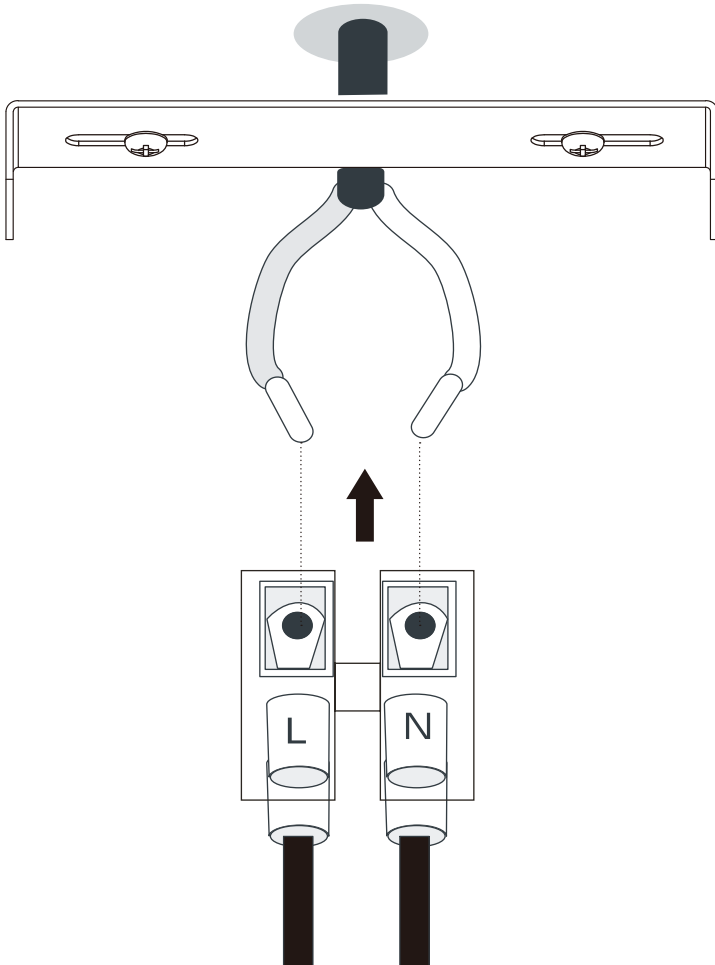

3

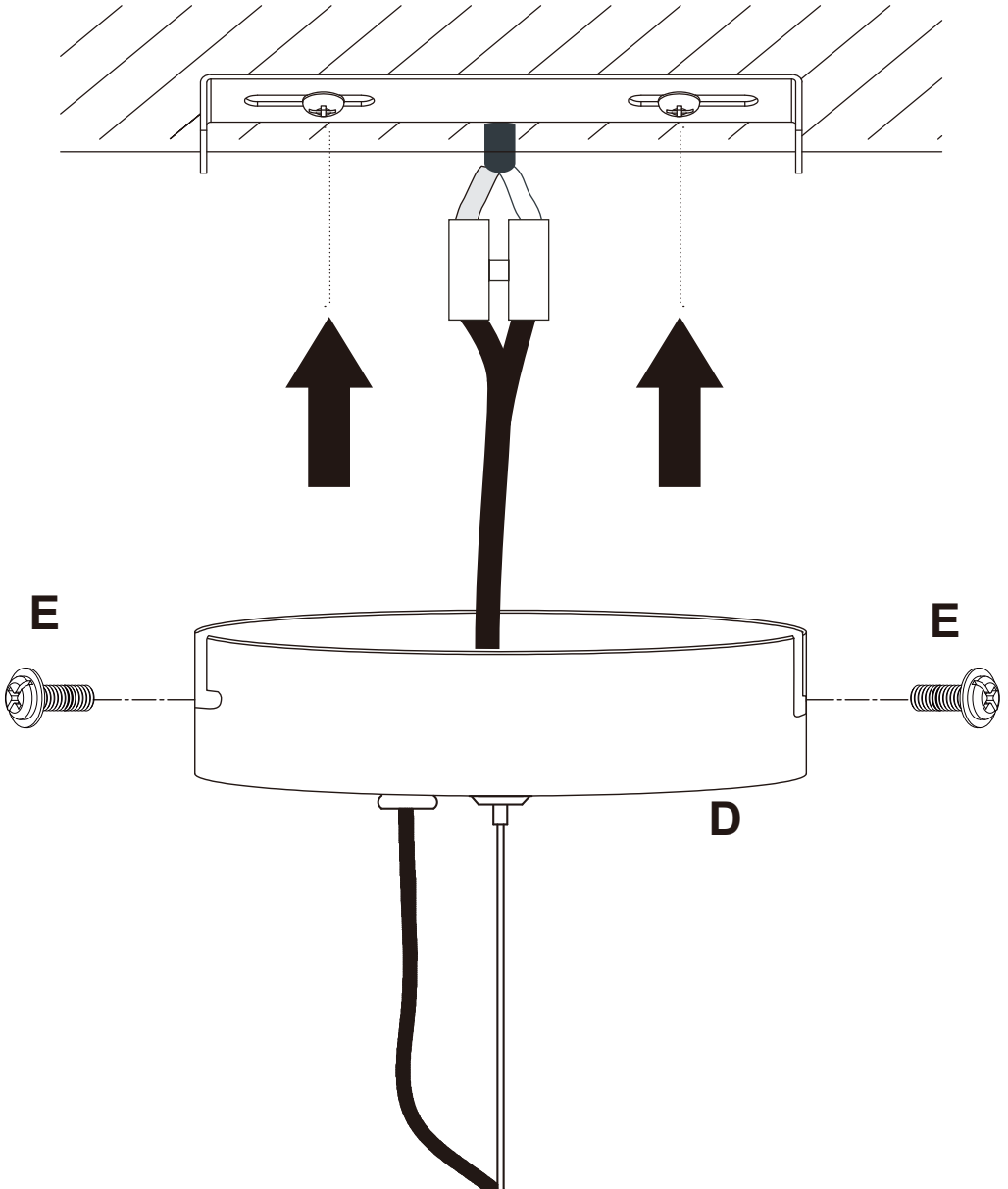

4













**THAT'S ALL FOLKS!**

Share your style!

**#KaveHome**

