

BRIDGES CABINETS
PILLOW SOFA
MASHEB SOFA

BATON COLLECTION
STEDELIJK CHAIR
MULTILEG COLLECTION

Novelties



Novelties

P. 3	BRIDGES CABINETS
P. 11	PILLOW SOFA
P. 17	MASHEB SOFA
P. 23	BATON COLLECTION
P. 29	STEDELIJK CHAIR
P. 35	MULTILEG COLLECTION



Bridges is a collection of cabinets designed by Muller Van Severen. MVS developed the cabinets from their series of 'Wave' vases. The vase silhouettes were brought into handmade cabinets with unique cutout bases that transcend function. Their refined colours and glossy finishes emphasise structure, standing out with a sculptural beauty. Alone or as a whole, the Bridges cabinets create a colourful architecture that is vibrant and spacious and, of course, full of personality.

Bridges cabinets





FINISHES

Cabinet collection with three different heights (900, 1400, 1800).
 Designed in four different colors; NCS 3060-B90G (Green), NCS 3560-Y80R (Red),
 NCS 7020-R80B (Blue), NCS 8010-R10B (Aubergine).

MEASUREMENTS (CM)

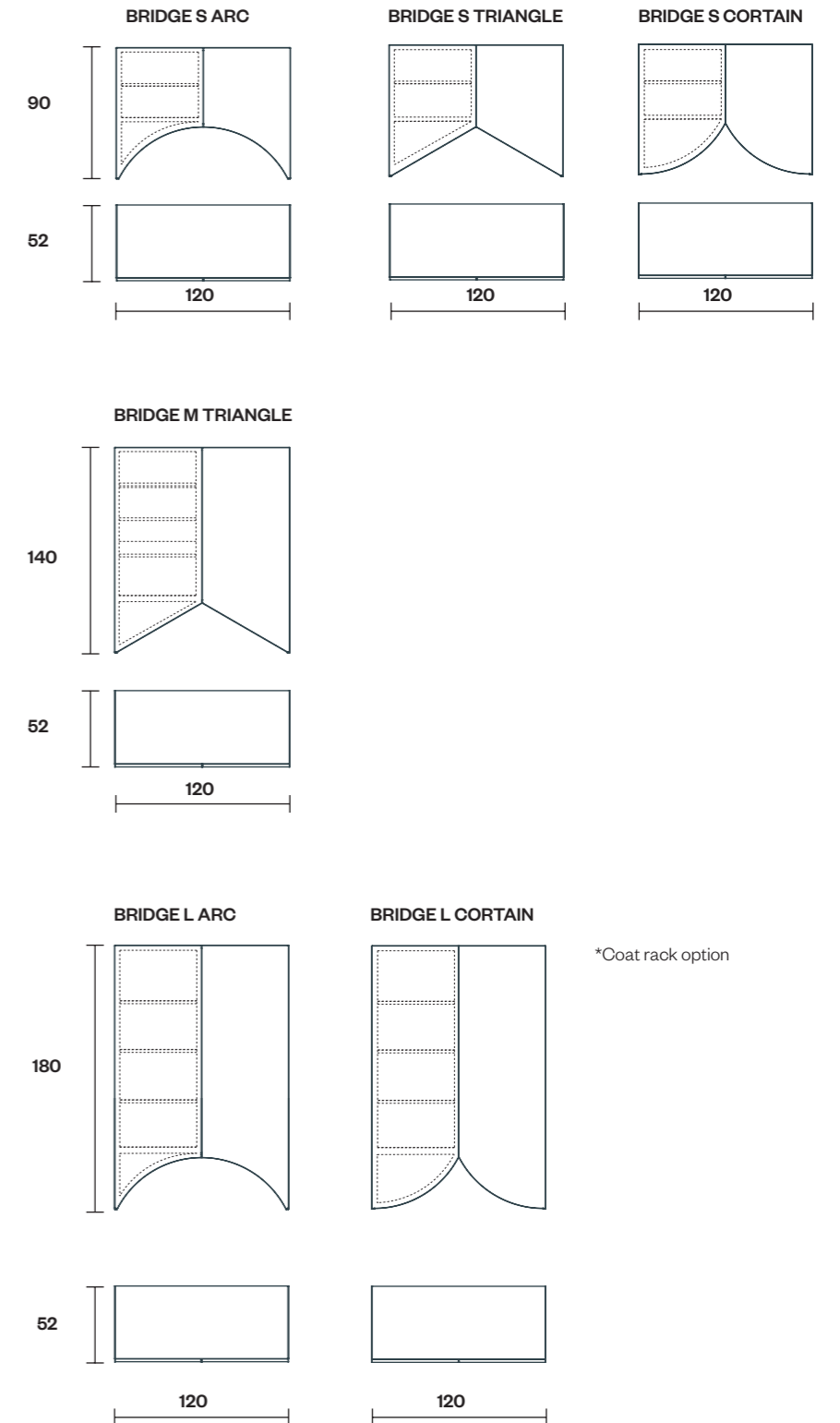

DESIGNER



MULLER VAN SEVEREN



Muller Van Severen's Pillow sofa modular arrives at BD. Initially designed by MVS for KASSL Editions, the Pillow sofa has been improved into a new playful and modular system for BD. The independent pillows are crisp and richly hued, perfect for puzzling together to create a fusion of comfortable seating arrangements. Edges curve smoothly and combine into an array of environments where style and grace meet a plush expression of form. One where cushions mix, match, adapt, and grow, wherever they are.

Pillow sofa





FINISHES

Modular seating system. Detachable pillows with removable covers. Cushions in polyether foam + polyester wadding upholstered in leather and BD fabrics TBC. Tubular steel structure powdercoated in anthracite color. Soft or hard flooring glides included.

MEASUREMENTS

CENTRAL MODULE

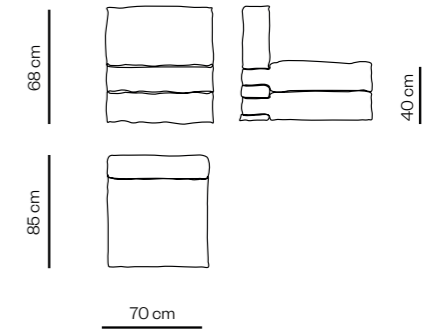

CORNER MODULE

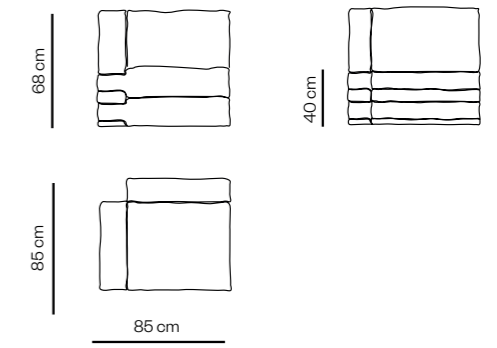

ARMCHAIR MODULE

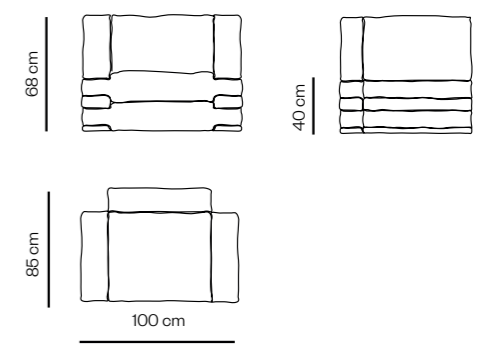

DESIGNER



MULLER VAN SEVEREN

MODULARITY EXAMPLES

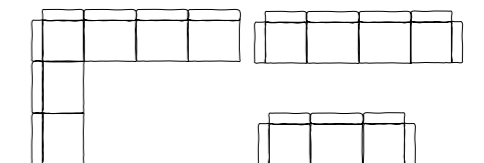



The unique personality of the architectural office is held in a playful sofa with a striking visual presence. Arquitectura - G plays with the concept of solidity through extremely simple bodies. Its prismatic square and triangular cushions sit on prismatic blocks that rise above solid-turned aluminium legs. Available in three sizes, the Masheb works as an individual module or can intertwine with multiple elements to adapt to both casual situations and formal environments. It is a rectilinear system with the softness of Alcantara and the versatile and carefree pleasure of a refined geometry.

Masheb sofa





FINISHES

The structure is made of white painted steel. There is also a wooden structure made of pine and white laminated MDF. The legs are made of solid brushed aluminum with a wax finish. At the end of them there are adjustable feet made of rubber. The seats have different density polyester foams. The cushions have a mdf and steel base and different density polyester foams. The upholstery of the whole product is tight and not removable. The fabric options are: Alcantara pannel C/4978 and Combo (Fiberguard) 10 premium. For more BD fabric options, please contact us. The modules can be grouped in such a way that different sizes and forms of sofas can be obtained. The cushions can also be positioned to the consumer's taste.

MEASUREMENTS

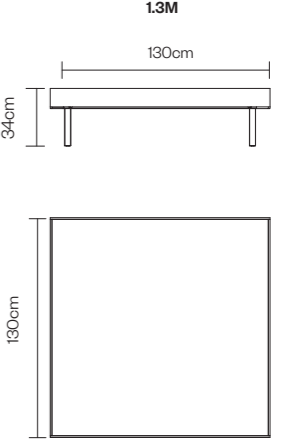
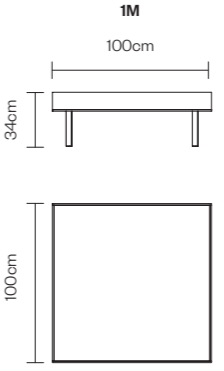

DESIGNER



ARQUITECTURA-G

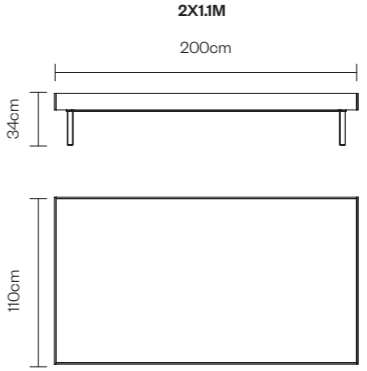

CUSHIONS

TRIANGULAR

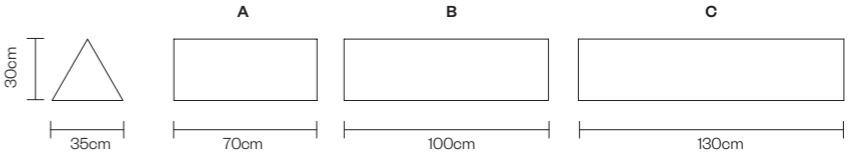

SQUARE

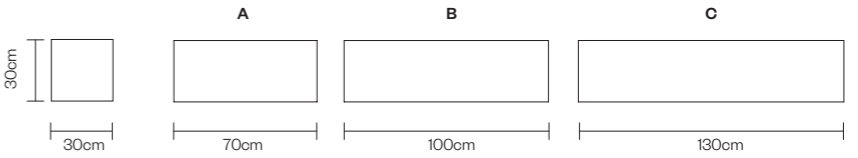



The Baton Collection is an example of Ronan Bouroullec's design aesthetic. His creative mind stands strong in the Baton's slim and tall frame, in all its variations. As a standalone or group, the Baton collection has a sublime simplicity that transforms its surroundings into a unique and personal space. It carves around the shape of a cane, generating subtle harmonies in the home or a shared space. It is a minimal frame with multiple uses.

Baton collection





FINISHES

Base in gravity die casting steel, polished and powder coated in textured black. Inox steel polished curved tube used as a handle. Steel rod fixed to the base, powder coated in black matt. Inox steel polished curved tube to fix the candle holder.

MEASUREMENTS (CM)

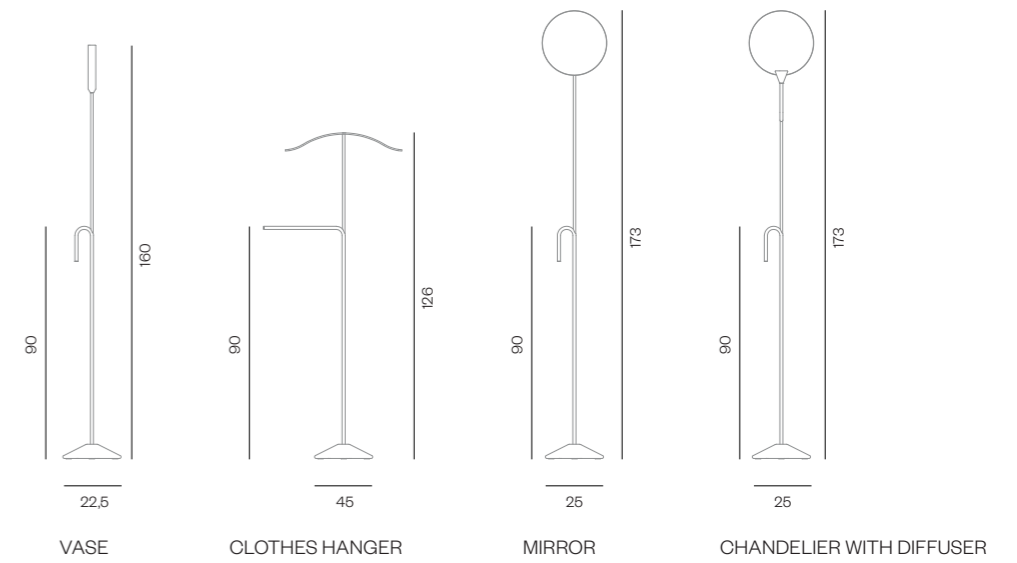

DESIGNER



RONAN BOURULLEC

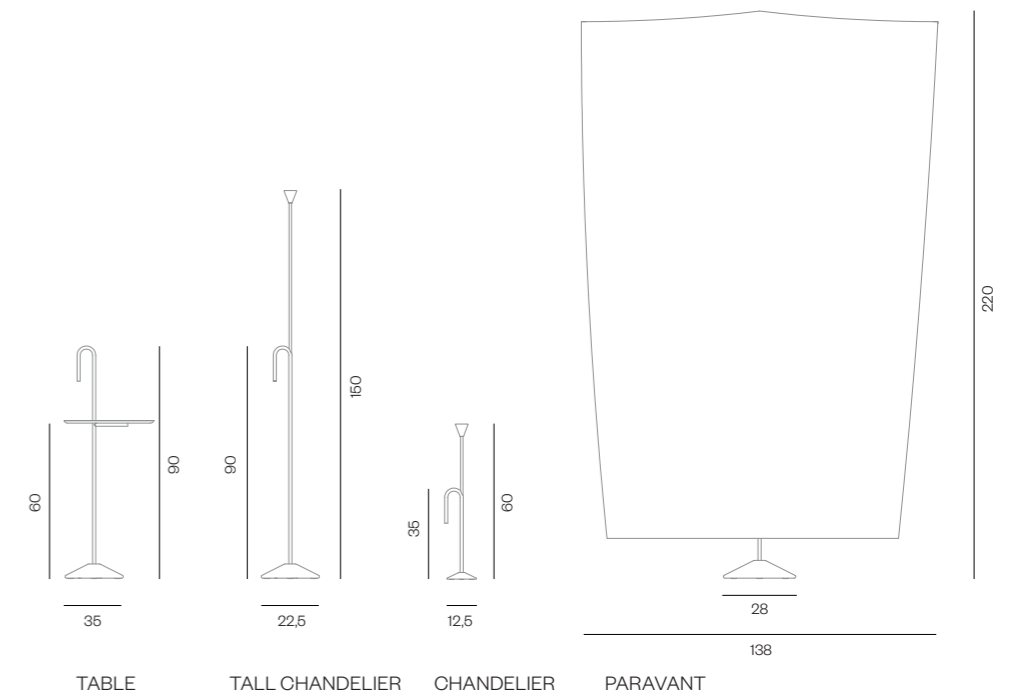



The The Stedelijk Chair is the first chair by Dutch designer Sabine Marcelis. Commissioned by the Stedelijk Museum Amsterdam, renowned for its design collection, the Stedelijk Chair has a strong character that exemplifies Sabine Marcelis' design style. Handmade and brimming with visual appetite, aluminium flows from legs to backrest with a smooth cohesion that accentuates its materiality. Its flowing silhouette compliments the smooth white form of the Stedelijk Museums exterior. Sabine Marcelis merges timeless design and sculpture in a chair that is stackable, lightweight and made of a 100% aluminium body.

Stedelijk chair





FINISHES

The whole chair is made of welded aluminum, it has a brushed finish with teflon varnish coverage. Polypropylene glides included.

MEASUREMENTS (CM)

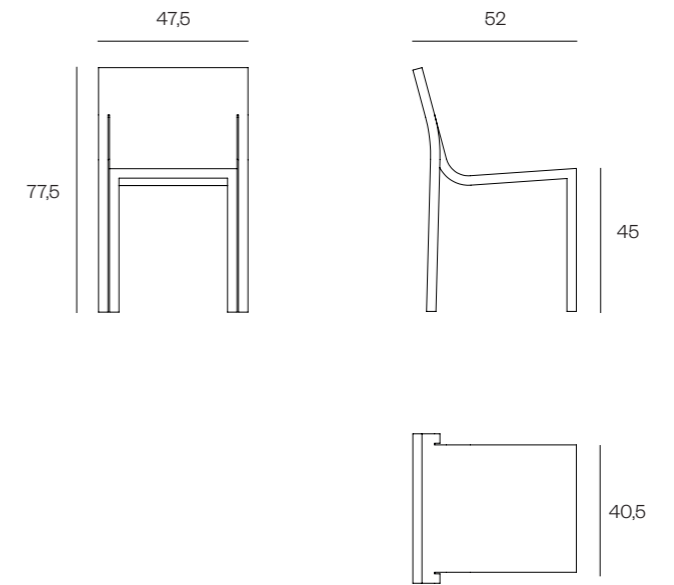

DESIGNER



SABINE MARCELIS



Jaime Hayon designed the Multileg collection in 2006, and it has cast a playful light on the BD catalogue ever since. Its new finish and colours stimulate feeling over unique and gestural legs. The Multileg collection is approachable and impressive, a perfect example of a Hayon. Its modularity couples with a simple design and a dozen leg options, accompanying a space with a creative flair and a selection of vibrant finishes. It's a contemporary classic.

Multileg collection





FINISHES

Base and top in MDF with a gloss lacquer and 1cm-thick glass top or in natural ash MDF open-pore and painted with an additional ash top.

Gloss lacquer body available in off-white, black, electric blue and dark blue. Open-pore body available in hazy blue, egg yolk, black, olive green and berry red.

Optional marble top.

Legs in solid turned alder wood lacquered in gloss or open-pore and painted in the same colour as the whole piece.

MEASUREMENTS

MODEL 1 M

100 x 50 x 80 cm
39,3 x 19,6 x 31,5"

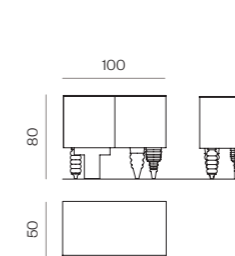

MODEL 1 M + 1 M

100 x 50 x 130 cm
39,4 x 19,6 x 51,1"

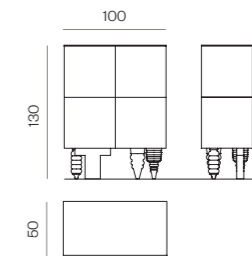

MODEL 1,5 M

150 x 50 x 80 cm
59 x 19,7 x 31,5"

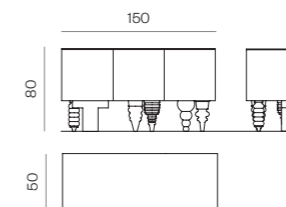

MODEL 2 M

200 x 50 x 80 cm
78,7 x 19,6 x 31,5"

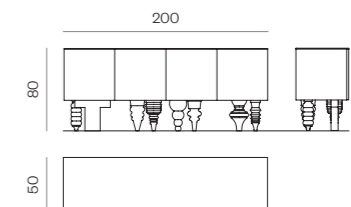

MODEL 2,5 M

250 x 50 x 80 cm
98,4 x 19,6 x 31,5"

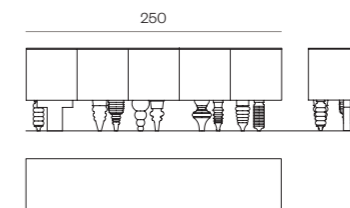

MODEL 3 M

300 x 50 x 80 cm
118,1 x 19,6 x 31,5"

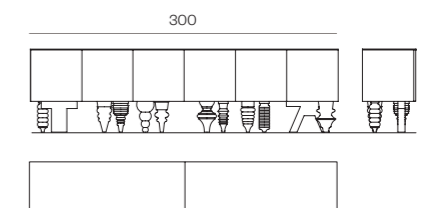

DESIGNER



JAIME HAYON



BD BARCELONA
RAMON TURRÓ 126, 08005 BARCELONA (SPAIN)
(+34) 934 586 909
SALES@BDBARCELONA.COM