

TECHNICAL CHARACTERISTICS

SSUPTE

Supra

Trumpet Chair

The Supra chair, an elegant shell with character, in combination with different structures, is a perfect product for diverse spaces and uses.

Inspired on the structural beams constructive principles Supra achieves the feeling of both independent seat and back parts in a unique solid piece.

DESIGNED BY NOTE DESIGN STUDIO



ondarreta

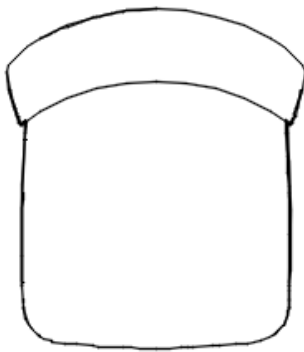
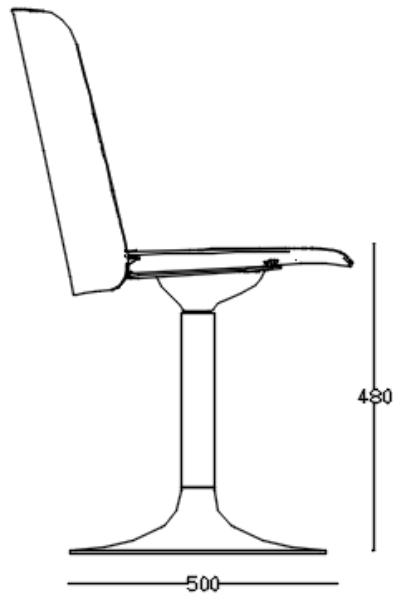
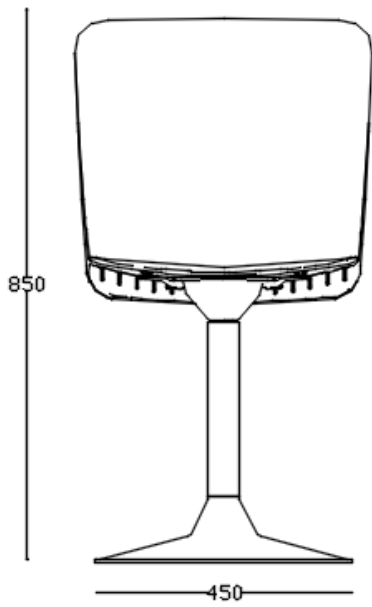

DIMENSIONS

45 cm x 50 cm x 85 cm x 48 cm
[width x depth x height x seat
height]

WEIGHT

8 kg

PACKAGING

One piece per box.

Box dimensions: 55.3 cm x 41 cm x
97.5 cm

ACCESSORIES

Felt glides

ORIGIN

100% Made in Europe

DESIGN

Note Design Studio



COMPONENTS

FRAME

Material

Base and injection-molded aluminum mounting plate.
50 mm diameter steel column with auto-return gas.

Finish

Epoxy Selected Colors

SHELL

Special Raw Textured Polypropylene

Special raw copolymer translucent textured polypropylene with matt finish. Very good mechanical properties, translucency and lightness.

Technical Features:

Density (per ISO 1183): 900 kg/m³;

Yield stress (per ISO 527-1/-2): 23 N/mm²;

Flexural modulus (per ISO 178): 1100 N/mm² (23°C)

Finish

Matt textured polypropylene, fully upholstered, or seat upholstered

UPHOLSTERY

Fully upholstered

Exclusive and unique upholstery system that allows the fabric a perfect adherence to the shell (both seat and back), maintaining the own chair's shape. Medium density polyether stuffing foam.

Upholstered seat-pad

Exclusive and unique upholstery system that allows the fabric a perfect adherence to the seat, maintaining the own chair's shape. Medium density polyether stuffing foam.





METAL FINISHES

EPOXIES

Powder coating formulated with polyester resins with good mechanical and chemical properties, maximum outdoor resistance, and free of harmful compounds (TGIC). Electrostatic application and oven cured at 200°C.

Technical Features:

Film thickness (per ISO 2360): between 60 and 90 µm; Grid adherence (per ISO 2409): Grade 0 (maximum adherence).

FABRIC REQUIREMENTS

Upholstered seat: 55 cm

Fully upholstered (seat + back) 110 cm

