

capdell



Novelties / Novedades

capdell

Calle Flora Tristán, 24, 46970 Alaquàs, Valencia, España

+34 961 502 950

info@capdell.com

Seat and stools /
Asientos y taburetes



6 ATRIA
by Gabriel Teixidó



14 CÉCILE
by Mario Ruiz



22 HELIUM
by David Redondo



28 LEIZU
by EstudiHac



36 MARIETA
by Yonoh



46 NARA
by Mario Ruiz



56 ULIS
by Sebastian Hekner

Sofas / Sofás

4



64 BOLERO
by Claesson Koivisto Rune

Tables / Mesas



72 ATRIA
by Gabriel Teixidó



78 NOOK
by Mario Ruiz

All our collections /
Todas nuestras colecciones

88

NOVELTIES /
NOVEDADES

6



ATRIA collection

Design by Gabriel Teixidó

EN Atria is a collection of seats that includes a chair, an armchair and a lounge chair. Its soft and light shapes emanate the warmth of the materials, solid oak for the structure and leather for the seat and back.

The detail of the seam at the ends of the seat and backrest stands out, and the braiding that tightens the leather in the lower part. Its name refers to the atrium of Roman houses, around which the social life of the house revolved. It also means the brightest star.

ES Atria es una colección de asientos, compuesta por silla, silla con brazos y butaca. Sus formas suaves y ligeras emanan la calidez de los materiales, el roble macizo para la estructura y cuero en asiento y respaldo.

Destaca el detalle de la costura en los extremos del asiento y el respaldo, y el trenzado que tensa el cuero en la parte baja. Su nombre hace referencia al atrio de las viviendas romanas, en torno al cual giraba la vida social de la casa. También significa la estrella que más brilla.

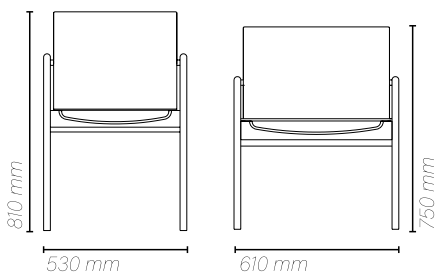







10





12

ATRIA collection

Chair / Sillas



2323

Oak wood stained arm chair with traditional upholstered of premium leather / Silla con brazos y sin brazos Atria, estructura de madera de roble teñida en S80 con tapizado tradicional de cuero premium



2322

Oak wood stained chair with traditional upholstered of premium leather / Silla con brazos y sin brazos Atria, estructura de madera de roble con tapizado tradicional de cuero premium



2325

Oak wood stained lounge chair with traditional upholstered of premium leather / Butaca con estructura de madera de roble con tapizado tradicional de cuero premium



CÉCILE collection

Design by Mario Ruiz

EN Cécile is a timeless design chair collection in organic and welcoming shapes, a wonderfully comfortable piece that praises craftsmanship, and with great adaptability to different scenarios and uses.

Its simplicity results in versatility to adapt to spaces of a very different nature, both in contract, in multipurpose spaces, in flexible and reconfigurable hybrid areas, and at home.

Despite its lightness, it is a chair with a robust identity, with a characteristic language of curves and counter-curves in a 36 mm diameter cylindrical structure with no visible joining elements. Consistent with the lines outlining the structure of the piece, the seat and backrest have a gentle curvature that envelops the body with balanced proportions.

The chair can be entirely made in wood, or with the seat and backrest upholstered combining various densities of polyurethane foam. In its metallic version, with painted steel tube, its appearance conveys the same warmth as the wooden version while maintaining its enveloping shapes and delivering an image of great comfort.

In addition to these two versions, there is also an outdoor Cécile with an aluminium structure, seat and backrest and the possibility of upholstery on the seat. All versions are stackable.

ES Colección de sillas de diseño atemporal, de formas orgánicas y acogedoras, Cécile es una pieza muy comfortable que ensalza el trabajo artesanal y que tiene una gran capacidad de adaptación a diferentes escenarios y usos.

Su sencillez se traduce en versatilidad para adaptarse a espacios de muy diferente naturaleza, tanto en contract, en espacios polivalentes, híbridos flexibles y reconfigurables, así como en hogar.

Pese a su ligereza, se trata de una silla de identidad robusta, con un lenguaje característico de curvas y contracurvas en una estructura cilíndrica de 36 mm de diámetro sin elementos de unión vistos. En coherencia con las líneas que dibujan la estructura de la pieza, el asiento y el respaldo tienen también una suave curvatura que envuelve el cuerpo con unas proporciones equilibradas.

La silla puede ser totalmente en madera o con el asiento y respaldo tapizado combinando varias densidades de espuma de poliuretano. En su versión metálica, con tubo de acero pintado, su apariencia proyecta la misma calidez que la versión de madera y mantiene las formas envolventes transmitiendo una imagen de mucho confort.

Además de estas dos versiones, Cécile tiene también una versión de silla para exterior con estructura de aluminio, asiento y respaldo de aluminio con la posibilidad de tapizado en el asiento. En todas sus versiones se trata de una pieza apilable.

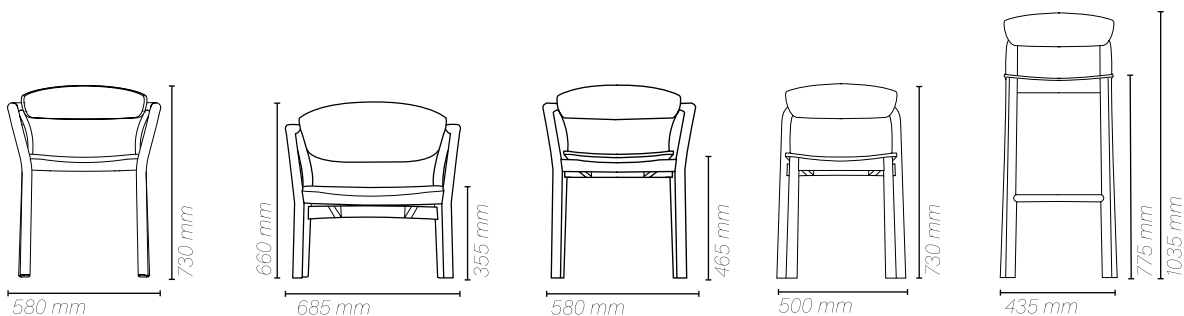







18





20

CÉCILE collection

Chair / Sillas



2341M

Chair with ash solid wood structure and seat and back of ash plywood / Silla con estructura de madera maciza de fresno y asiento y respaldo en madera contrachapada

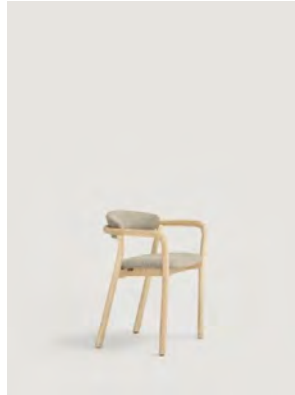

2341T

Chair with ash solid wood structure and seat and back upholstered / Silla con estructura de madera maciza de fresno y asiento y respaldo tapizado



2342M

Chair with metal structure and seat and back of ash plywood / Silla con estructura de metal y asiento y respaldo en madera contrachapada

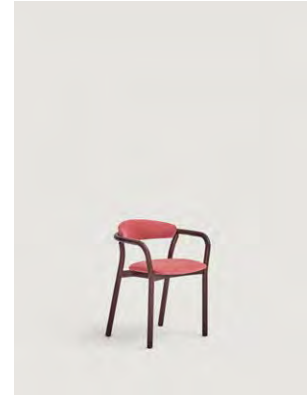

2342T

Chair with metal structure and seat and back upholstered / Silla con estructura de metal y asiento y respaldo tapizados

Outdoor / Exterior



2343M

Chair with solid ash wood frame. Front and back in plywood / Silla con madera maciza de fresno. Asiento y respaldo de madera

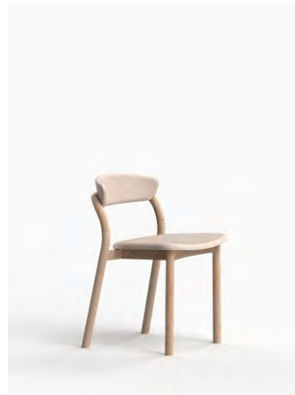

2343T

Chair with solid ash wood frame. Upholstered front and back / Silla con madera maciza de fresno. Asiento y respaldo tapizado



2341MIR

Chair with Iroko solid wood structure, seat and back / Silla con estructura, asiento y respaldo de madera maciza de Iroko



2141AL

Chair with aluminium structure, seat and backrest / Silla con estructura, asiento y respaldo de aluminio

Lounge / Butaca



2345M

Armchair with solid ash wood frame. Front and back in plywood / Butaca con madera maciza de fresno. Asiento y respaldo de madera



2345T

Armchair with solid ash wood frame. Upholstered front and back / Butaca con madera maciza de fresno. Asiento y respaldo tapizado

Stool / Taburete



2349M

Barstool with solid ash wood frame. Front and back in plywood / Taburete con madera maciza de fresno. Asiento y respaldo de madera



2349T

Barstool with solid ash wood frame. Upholstered front and back / Taburete con madera maciza de fresno. Asiento y respaldo tapizado



HELIUM collection

Design by David Redondo

EN Helium collection is unique and original design makes it an object that invites exploration and touch. Every detail has been carefully thought out to offer the user an incomparable experience.

The first contact with the chair is a sensation of comfort, thanks to its generous and protruding volumes. These volumes are inspired by the works of Jeff Koons and give the chair a commanding and distinctive presentation. However, its light and subtle appearance gives it a feeling of buoyancy, as if it were filled with helium.

ES Su diseño único y original la convierte en un objeto que invita a la exploración y al tacto. Cada detalle ha sido cuidadosamente pensado para ofrecer al usuario una experiencia incomparable.

El primer contacto con la silla es una sensación de comodidad, gracias a sus volúmenes generosos y protuberantes. Estos volúmenes están inspirados en las obras de Jeff Koons y le dan a la silla una presencia imponente y distintiva. Sin embargo, su apariencia liviana y sutil le otorga una sensación de flotabilidad, como si estuviera llena de helio.

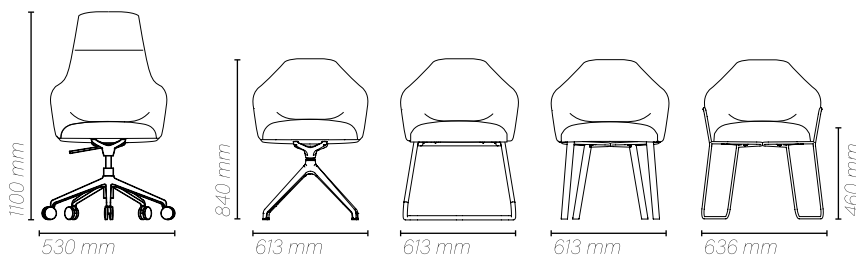







HELIUM collection

Chair / Sillas

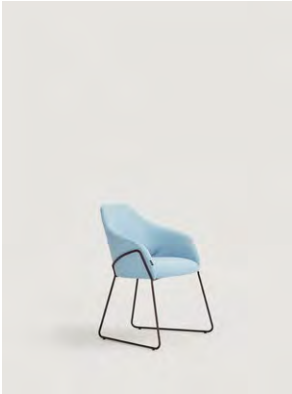

2330PTN
Upholstered chair with metal base / Silla tapizada con base de patín

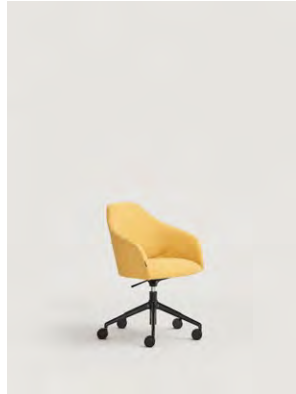

2330DR
Upholstered chair with five swivel aluminium base fitted with castor wheels / Silla tapizada con base de aluminio de cinco radios con ruedas

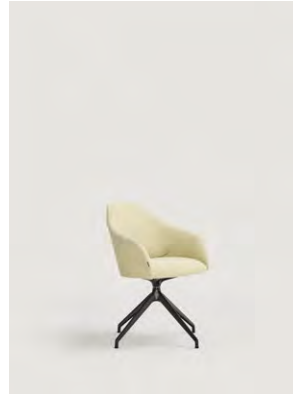

2330D
Upholstered chair with four swivel aluminium base / Silla tapizada con base giratoria de aluminio de cuatro radios

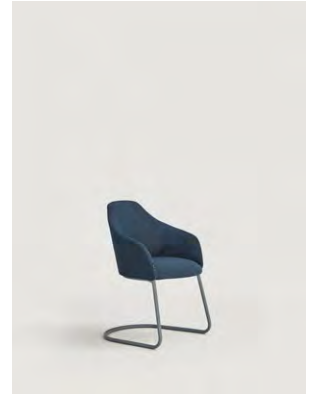

2330CAN
Upholstered chair with metal cantilever base / Silla tapizada con base de metal cantilevel



2330TNS
Upholstered chair with solid steel base / Silla tapizada con base de varilla de acero de tensor

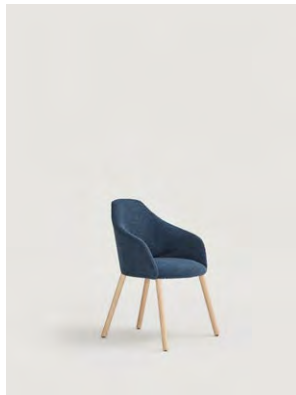

2330W
Upholstered chair with solid ash base / Silla tapizada con base de madera de fresno macizo

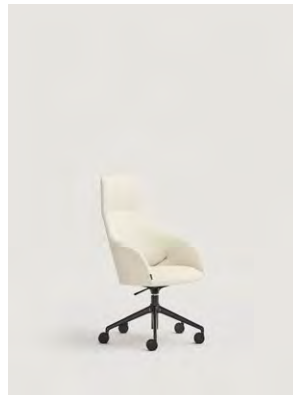

2331DR
Upholstered chair, high shell, with five swivel aluminium base fitted with castor wheels / Silla tapizada, carcasa alta, con base de aluminio de cinco radios con ruedas

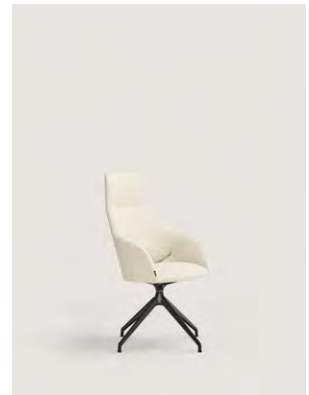

2331D
Upholstered chair, high shell, with four swivel aluminium base / Silla tapizada, carcasa alta, con base de aluminio de cuatro radios



LEIZU collection

Design by Estudi hac

EN The Leizu Collection draws inspiration from the delicacy and warmth of wool yarn, blending comfort with elegance to create a cozy and sophisticated ambiance.

This range of seating options, including both chairs and armchairs, features an ergonomic and inviting design that envelops you in a sense of comfort reminiscent of the comforting embrace of a wool yarn ball.

ES La Colección Leizu está inspirada en la delicadeza y la calidez de los ovillos de lana, esta colección fusiona la comodidad con la elegancia para crear un ambiente acogedor y sofisticado.

Esta línea de asientos, que incluye tanto sillas como butacas, ofrece un diseño ergonómico y acogedor, que te envuelve en una sensación de confort que recuerda al abrazo reconfortante de un ovillo de lana.

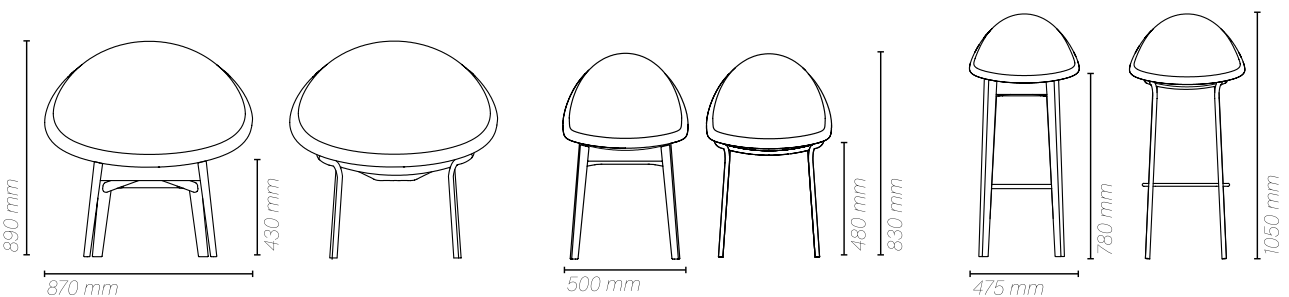



30



31









34

LEIZU collection

Chair / Sillas

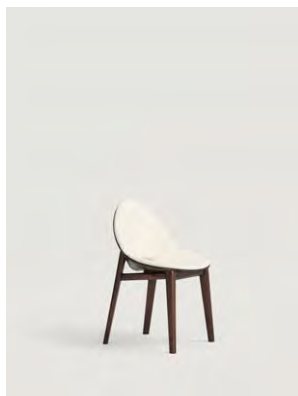

2411WP

Chair with solid ash wood frame. Upholstered front shell and wooden back shell / Silla con estructura de madera maciza de fresno. Carcasa delantera tapizada y trasera de madera

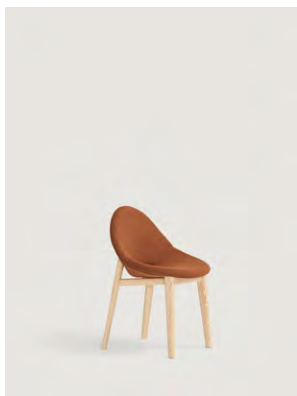

2411WT

Chair with solid ash wood frame, and upholstered shell / Silla con estructura de madera maciza de fresno, y carcasa tapizada

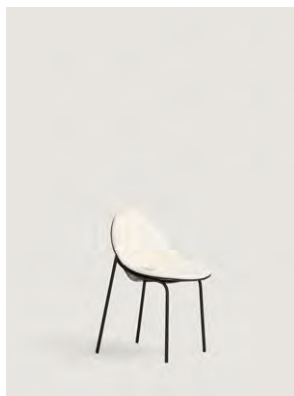

2411VP

Chair with steel frame. Upholstered front shell and wooden back shell / Silla con estructura de acero. Carcasa delantera tapizada y trasera de madera

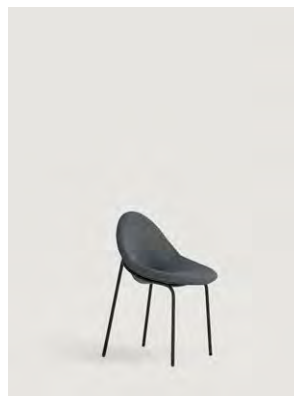

2411VT

Chair with steel frame, and upholstered shell / Silla con estructura de acero, y carcasa tapizada

Lounge / Butaca



2415WP

Armchair with solid ash wood frame. Upholstered front shell and wooden back shell / Butaca con estructura de madera maciza de fresno. Carcasa delantera tapizada y trasera de madera

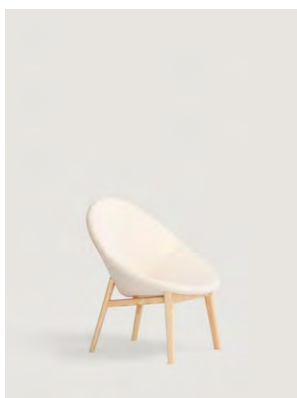

2415WT

Armchair with solid ash wood frame, and upholstered shell / Butaca con estructura de madera maciza de fresno, y carcasa tapizada



2415VP

Armchair with steel frame. Upholstered front shell and wooden back shell / Butaca con estructura de acero. Carcasa delantera tapizada y trasera de madera



2415VT

Armchair with steel frame, and upholstered shell / Butaca con estructura de acero, y carcasa tapizada

Stool / Taburete

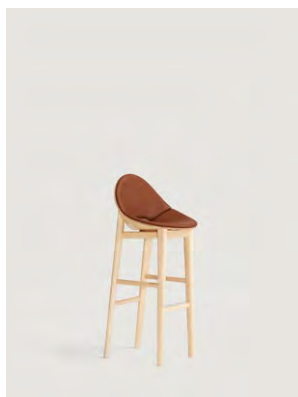

2419WP

Barstool with solid ash wood frame. Upholstered front shell and wooden back shell / Taburete con estructura de madera maciza de fresno. Carcasa delantera tapizada y trasera de madera

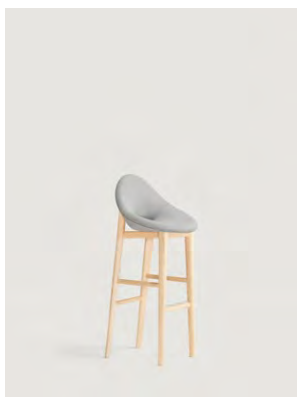

2419WT

Barstool with solid ash wood frame, and upholstered shell / Taburete con estructura de madera maciza de fresno, y carcasa tapizada

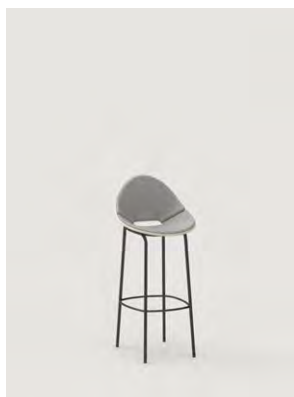

2419VP

Barstool with steel frame. Upholstered front shell and wooden back shell / Taburete con estructura de acero. Carcasa delantera tapizada y trasera de madera

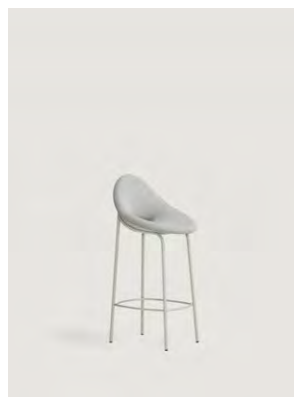

2419VT

Barstool with steel frame, and upholstered shell / Taburete con estructura de acero, y carcasa tapizada



36

MARIETTA collection

Design by Yonoh

EN Marietta is a collection with a very fresh and customizable design that leaves no one indifferent. Its name comes from Valencian, its translation is Mariquita, referring to the insect from which the design is inspired and emphasizing the local culture. A very funny aesthetic, seen from above, the structure, the seat and the backrest imitate the shape of this little insect, legs, body, head...

The collection consists of a chair, armchair, armchair and stool. It is stackable and has a version for outdoor spaces

ES Marietta es una colección con un diseño muy fresco y personalizable, que no deja indiferente a nadie. Su nombre proviene del Valenciano, su traducción es Mariquita, haciendo referencia al insecto en el que se inspira el diseño y poniendo el énfasis en la cultura local. Una estética muy divertida, visto desde arriba, la estructura, el asiento y el respaldo imitan la forma de este pequeño insecto, patas, cuerpo, cabeza...

La colección se compone de silla, sillón, butaca y taburete. Es apilable y tiene una versión para espacios exteriores

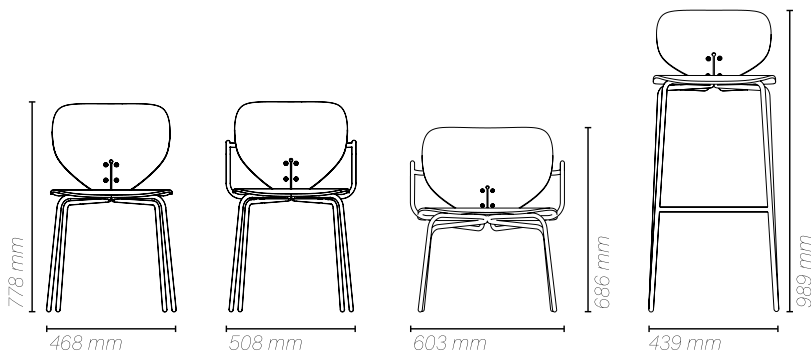















MARIETTA collection

Chair / Sillas

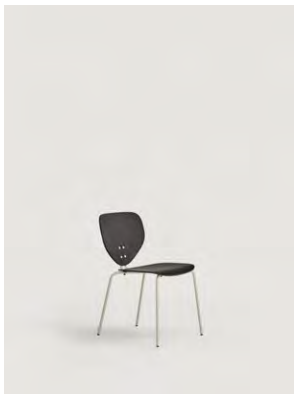

2311
 Chair with oak wood seat and back. Steel frame / Silla con asiento y respaldo de roble. Estructura de acero.

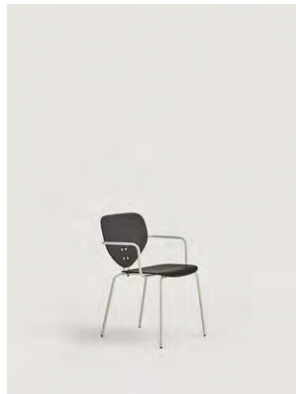

2311N
 Armchair with oak wood seat and back. Steel frame / Silla con brazos con asiento y respaldo de roble. Estructura de acero.

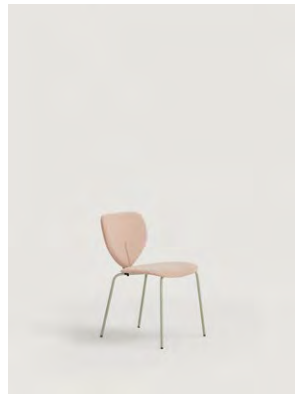

2311U
 Upholstered chair with steel frame / Silla tapizada con estructura de acero

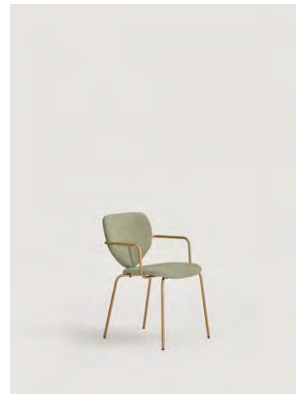

2311U-N
 Upholstered armchair with steel frame / Silla tapizada con brazos con estructura de acero

Outdoor / Exterior



2311INOX
 Outdoor chair with aluminium seat and back. Inoxidable steel frame / Silla de exterior con asiento y respaldo de aluminio. Estructura de acero inoxidable

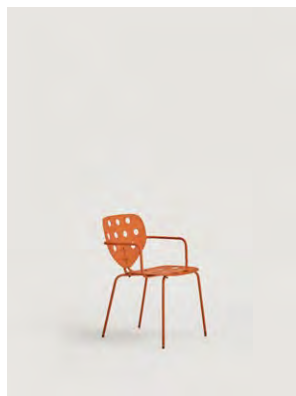

2311INOX-N
 Outdoor armchair with aluminium seat and back. Inoxidable steel frame / Silla de exterior con brazos con asiento y respaldo de aluminio. Estructura de acero inoxidable

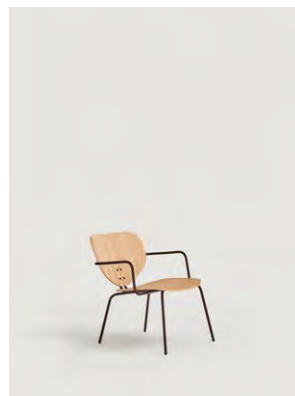

2315
 Lounge chair with oak wood seat and back. Steel frame / Butaca con asiento y respaldo de roble. Estructura de acero.



2315U
 Upholstered lounge chair with steel frame / Butaca tapizada con estructura de acero.

Stool / Taburete

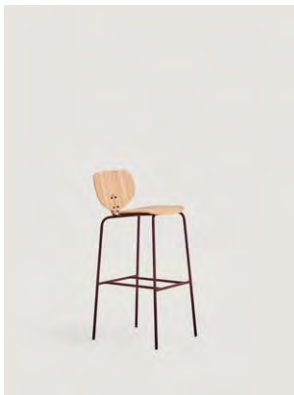

2319
 Stool with oak wood seat and back. Steel frame / Taburete con asiento y respaldo de roble. Estructura de acero.

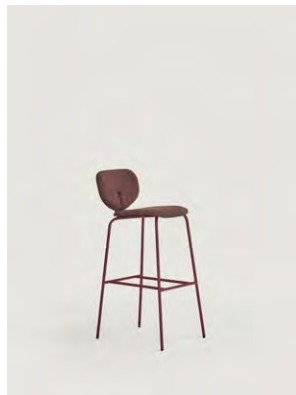

2319U
 Upholstered stool with steel frame / Taburete tapizado con estructura de acero.



NARA collection

Design by Mario Ruiz

EN Familia of three types of stools and two types of chairs. A stool with a liftable piston. The base piece of the leg hugs the column and gives uniqueness to the product. The rod option is also available and of course solid wood. All options are sized to create a harmonious set between base and seat. It has a marked symmetrical character, since all its curves are balanced on both axes. The seat has ergonomic curvature that adapts to the shapes of the body, providing comfort and comfort when sitting.

ES Familia de tres tipos de taburetes y dos de sillas. Un taburete con pistón elevable. La pieza base de la pata abraza la columna y le da singularidad al producto. También está disponible la opción de varilla y por supuesto de madera maciza. Todas las opciones están dimensionadas para que generen un conjunto armonioso entre base y asiento. Tiene un marcado carácter simétrico, ya que todas sus curvas se equilibran en ambos ejes. El asiento tiene curvatura ergonómica que se adapta a las formas del cuerpo aportando comodidad y confort en la sentada.

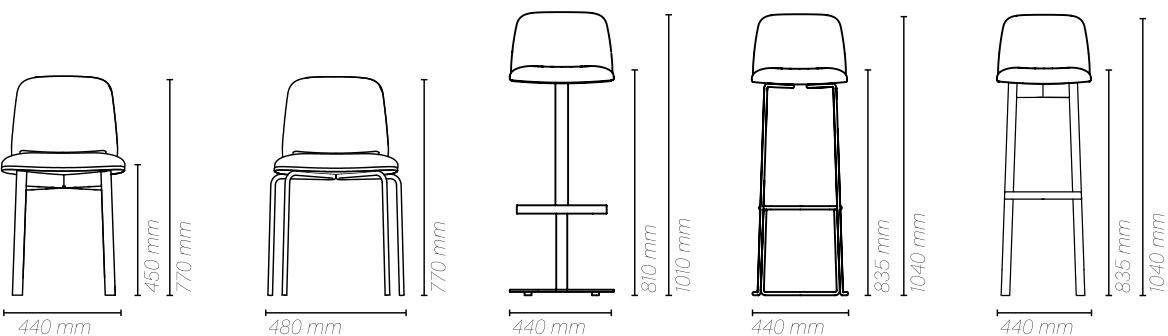







50









NARA collection

Chair / Silla



2201

Upholstered chair with solid beech wood frame / Silla con estructura de madera de haya maciza tapizada

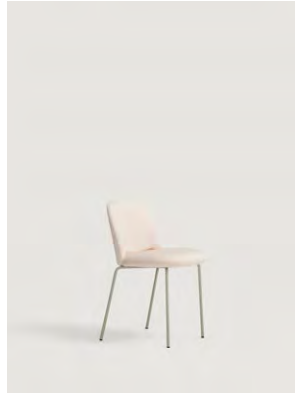

2202

Upholstered chair with steel frame / Silla con estructura de acero tapizada

Stool / Taburete



2209P

Upholstered stool with gas swivel base, adjustable height / Taburete tapizado con base de pistón, altura regulable

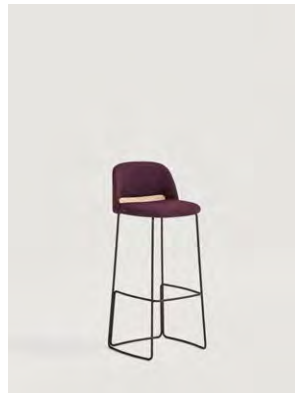

2209V

Upholstered stool with solid steel structure. Available in 65 cm height / Taburete tapizado con base de varilla. Disponible de 65 cm

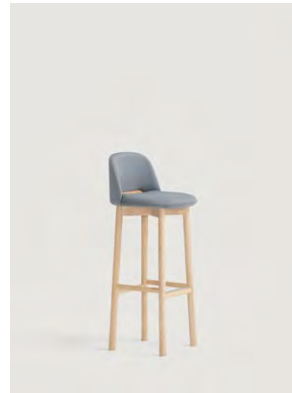

2209M

Upholstered barstool with steel frame. Seat height: 65 or 78 cm / Taburete tapizado con estructura de acero. Altura de asiento de 65 ó 78 cm



ULIS collection

Design by Sebastian Herkner

EN The design of the Ulis Lounge adapts to both residential and contract spaces. Sebastian Herkner defines it as his idea of a modern comfort. The soft aesthetic formed to wrap and embrace, guarantees a comfortable and a reclining position at the same time, and make this product space friendly and welcoming. The legs can be made of black metallic tube or a rotating central foot, which combines metal and oak. It is available in two heights.

ES Ulis Lounge se adapta tanto a espacios residenciales como contract. Sebastian Herkner lo define como su idea de confort moderno. Su estética soft, formada para envolver y abrazar, y al mismo tiempo garantizar una posición cómoda y reclinada hacen que este producto convierta los espacios en amables y acogedores. Las patas pueden ser de tubo metálico negro o un pie central giratorio, que combina metal y el roble. Disponible en dos alturas.

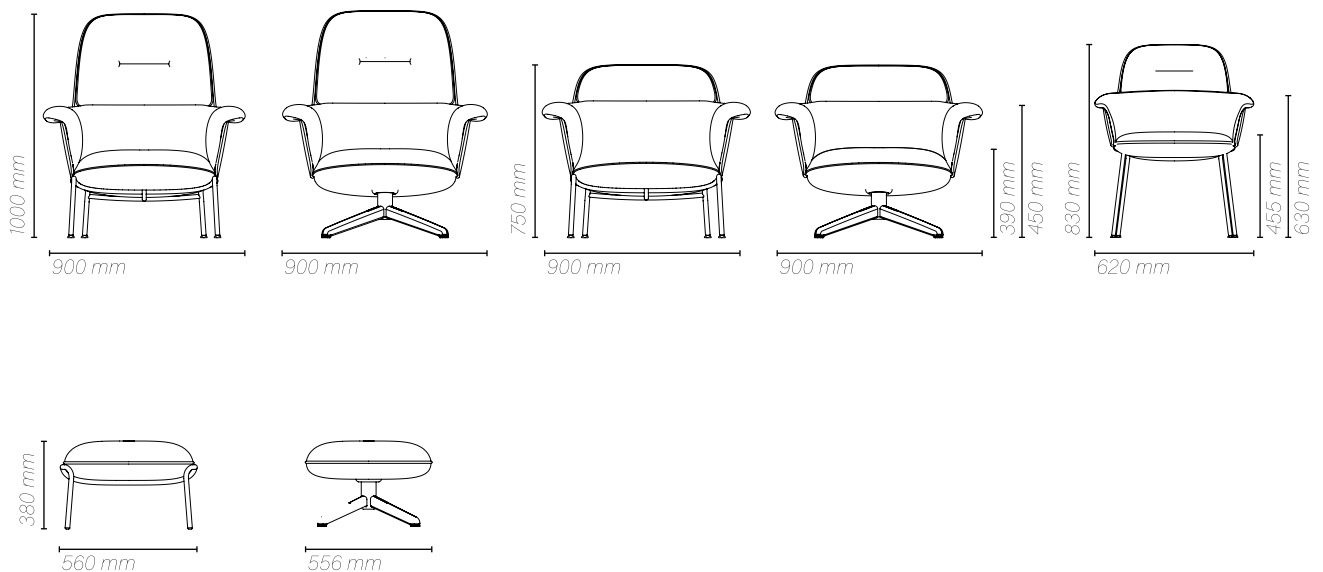











ULIS collection

Chair / Silla



2155
Upholstered armchair with metal legs /
Silla tapizada con patas metálicas

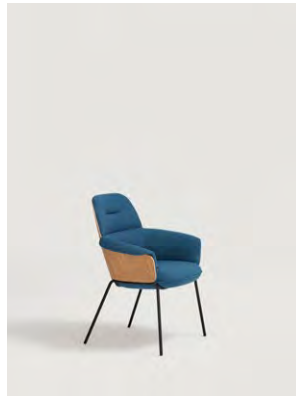

2155R
Upholstered armchair with oak wood
frame and metal legs / Silla tapizada
con carcasa de madera y patas
metálicas

Lounge / Butaca

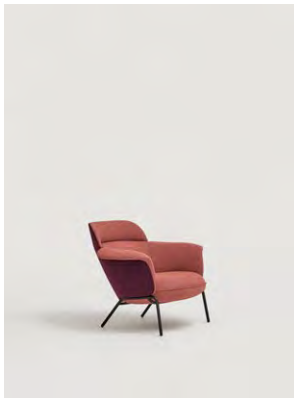

2152
Upholstered lounge chair with low case
and metal base / Butaca tapizada
con carcasa baja y base de metal



2151
Upholstered lounge chair with high
case and metal base / Butaca tapizada
con carcasa alta y base de metal

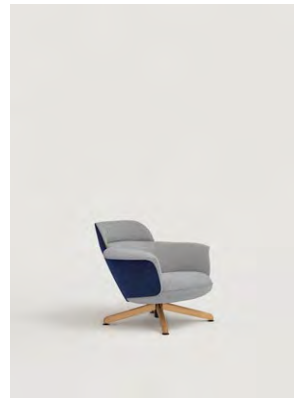

2152G
Upholstered lounge chair with low case
and wood base / Butaca tapizada con
carcasa baja y base de madera

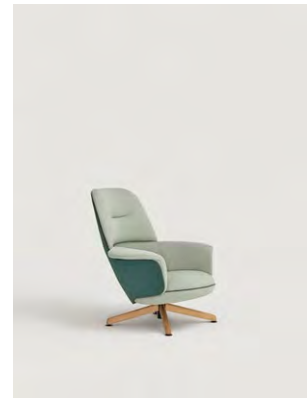

2151G
Upholstered lounge chair with high case
and wood base / Butaca tapizada con
carcasa alta y base de madera

Footrest / Reposapiés

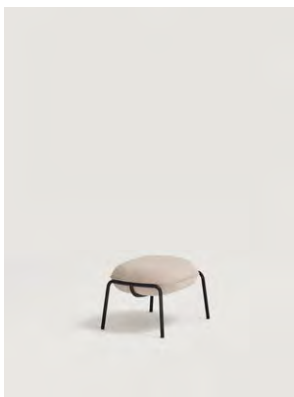

2158
Upholstered footrest with metal legs
/ Reposapiés tapizado con patas
metálicas



2158G
Upholstered footrest with oak wood
legs / Reposapiés tapizado con patas
de madera de roble



BOLERO collection

Design by Claesson Koivisto Rune

EN Bolero is a sofa with generous and sinuous shapes that invites you to be welcomed and embraced. The foam seat specially chosen for a comfortable sitting. The backrest is also covered with foams. The entire product is supported on a wooden base with straight lines, which contrast with the sinuosity of the product. Play between the curve, the straight line and the tangency. It is available in several versions: single-seater, two-seater and bench. The name comes from the inspiration of the designers "We think that the arm and back of the sofa resembles a collar, or more specifically a fur collar from the 1920s"

ES Bolero es un sofá de formas generosas y sinuosas que invita a la acogida y al abrazo. El asiento de espuma especialmente elegida para una sentada cómoda. El respaldo también está cubierto con espumas. Todo el producto va sustentado sobre una base de madera de líneas rectas, que contrastan con la sinuosidad del producto. Juega entre la curva, la recta y la tangencia. Está disponible en varias versiones: monoplaza, biplaza y bancada. El nombre viene de la inspiración de los diseñadores "Creemos que el brazo y el respaldo del sofá se asemejan a un cuello, o más específicamente a un cuello de piel de la década de 1920"

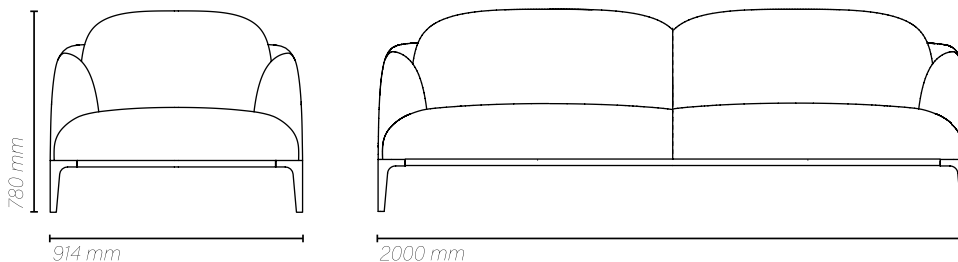











70

BOLERO collection

Sofas / Sofás



2211

*Upholstered one seat sofa with
beech wood base / Sofá de una plaza
tapizado con base de madera de haya*



2212

*Upholstered sofa with beech wood
base / Sofá tapizado con base de
madera de haya*



72

ATRIA Collection

Design by Gabriel Teixidó

EN Atria is a collection of seats that includes chairs, armchairs, lounge chairs and a table. Its soft and light shapes emanate the warmth of the materials: solid oak and premium leather.

Atria table comes with a solid oak wood structure. The top with an oak veneer finish. Available in 4 sizes: 200 x 100, 240 x 100, and 300 x 100 cm.

Its name refers to the atrium of Roman houses, around which the social life of the house revolved. It also means the brightest star.

ES Atria es una colección de asientos, compuesta por silla, silla con brazos, butaca y mesa. Sus formas suaves y ligeras emanan la calidez de los materiales: el roble macizo y cuero.

La mesa Atria está hecha con estructura de madera de Roble maciza. La tapa con acabado chapado en roble. Disponible en 4 tamaños: 200 x 100, 240 x 100 y 300 x 100 cm.

Su nombre hace referencia al atrio de las viviendas romanas, en torno al cual giraba la vida social de la casa. También significa la estrella que más brilla.

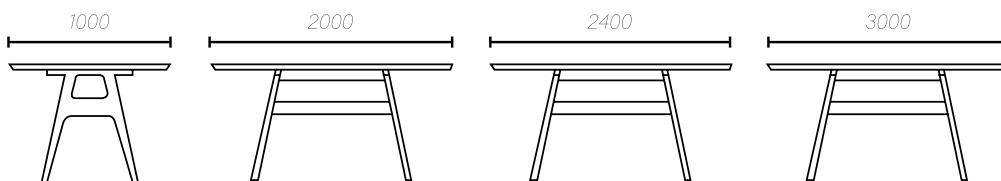





75



76

ATRIA collection

Table / Mesa



2322-1

Oak table with oak plywood top.
Mesa de roble on tapa chapada
en roble



NOOK collection

Design by Mario Ruiz

EN Collection of tables, available in central foot and rod, both in 2 heights.

Table with a central foot, with a concrete base: The concrete base has a central hole where the tube is situated. The diameter of the concrete's hole is the same as the diameter of the tube, so there is a formal continuity.

The metal rod table, like the stool, has a marked character of symmetry, and plays with the tangency of the rod.

The top of the table is modular, it is made up of two pieces: a common lower board, which adds character with its bevelling and gives continuity to the top.

ES Colección de mesas, disponible en pie central y en varilla, ambas en 2 altura.

Mesa de pie central, con base de hormigón: La base de hormigón tiene un agujero central donde se aloja el tubo. El diámetro de la boca del hormigón es el mismo que el diámetro del tubo, de modo que hay una continuidad formal.

La mesa de varilla metálica, al igual que el taburete, tiene marcado carácter de simetría, y juega con la tangencia de la varilla.

El top de la mesa es modular, está formado por dos piezas: un tablero inferior común, que aporta carácter con su biselado y da continuidad a la tapa.

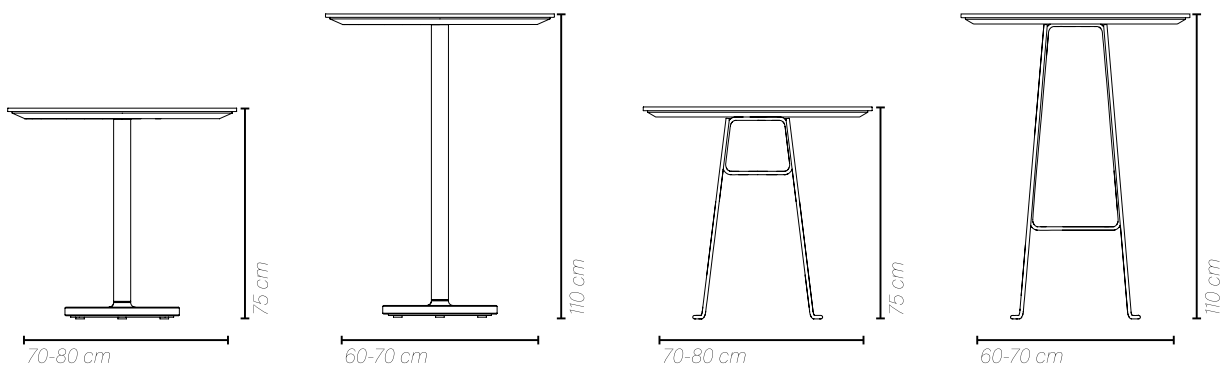















86

NOOK collection

Table / Mesa



TNC74

Table with concret and steel base.
Modular top, it is made up of two pieces
/ Mesa con base de cemento y acero.
Tapa formada por dos piezas



TNC110

High table with concret and steel base.
Modular top, it is made up of two pieces
/ Mesa alta con base de cemento y
acero. Tapa formada por dos piezas

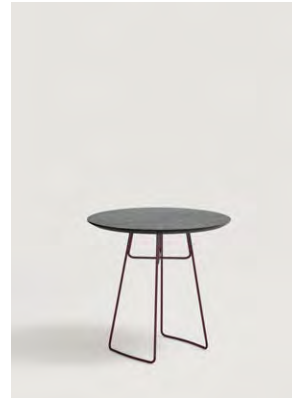

TNV74

Table with metal rod base. Modular
top, it is made up of two pieces /
Mesa con base de varilla de acero.
Tapa formada por dos piezas

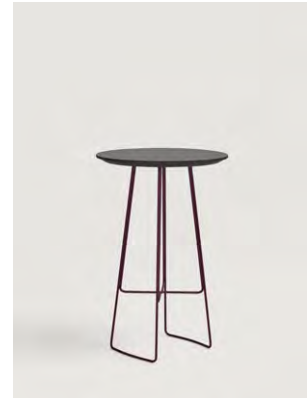

TNV110

High table with metal rod base.
Modular top, it is made up of two pieces
/ Mesa alta con base de varilla de
acero. Tapa formada por dos piezas

All our collections

Seat and stools /
Asientos y
taburetes



A-Collection
by Fran Silvestre



ARO
by Carlos Tíscar



ATRIA
by Gabriel Teixidó



AVA
by Carlos Tíscar



ECO
by Carlos Tíscar



FLICK
by Vicente Soto



HELIUM
by David Redondo



ICONICA
by Gabriel Teixidó



MARTA
by Gabriel Teixidó



MATCH
by Patrick Norguet



MOON
by Gabriel Teixidó



NARA NEW
by Mario Ruiz



NIX
by Patrick Norguet

88

Sofas /
Sofás



ATOLL
by Fiorenzo Dorigo



BOLERO
by Claesson Koivisto Rune



BRIDGE
by Vicente Soto



DROPLETS
by Claesson Koivisto Rune

Tables /
Mesas



ABLE
by Fiorenzo Dorigo



ARO
by Carlos Tíscar



ATRIA NEW
by Gabriel Teixidó



BASIC TABLES
by Capdell



INSULA
by Patrick Norguet



LIBRIS
by Vicent Martínez



NOOK
by Mario Ruiz



CAPITA
by Fiorenzo Dorigo



CÉCILE NEW
by Mario Ruiz



COL
by Francesc Rifé



CONCORD
by Claesson Koivisto Rune



DUAL
by Carlos Tíscar



ICS
by Fiorenzo Dorigo



ISA
by Vicent Martínez



LEIZU NEW
by Estudi hac



LOOP
by Patrick Norguet



MARIETA
by Yonoh



PANEL
by Lucy Kurrein



POLO
by Yonoh



STIR
by Kazuko Okamoto



ULIS
by Sebastian Hekner



WEDGE
by Marcel Sigel



INSULA
by Patrick Norguet



NODAL
by Luca Nichetto



PLUM
by Claesson Koivisto Rune



VISION
by Fiorenzo Dorigo



DROPLETS
by Claesson Koivisto Rune



GUS
by Francesc Rifé



GAZELLE
by Claesson Koivisto Rune



MESANA
by Salvador Vallalba



MESANA DESK
by Patrick Norguet



TRISTAR
by Claesson Koivisto Rune



W
by Gabriel Teixidó

Credits / Créditos

Printed in • Impreso en Valencia

Copyright © 2024 Capdell

All rights reserved / Todos los derechos reservados

Artesanía · Sostenibilidad · Innovación · Diseño