

Alberta

Martín Consuegra



EN

Timeless elegance and contemporary luxury like a lifestyle and fashion trend. Luxury is to have a single piece, full of personality, charming, with classical forms but contemporary. Design and craftsmanship generate a singular concept with strong identity.

SP

Elegancia atemporal clave del lujo contemporáneo como forma de vida y tendencia de moda. Lujo es tener una pieza única, llena de personalidad, encantadora, de formas clásicas, pero contemporánea. Convergencia del diseño y la maestría artesanal, generadora de un objeto único, rico de su fuerte identidad, abierto, reducido radicalmente en términos de materialidad y vocabulario de diseño.

FR

Élégance intemporelle, clé du luxe contemporain comme une façon de vivre et tendance à la mode. Le luxe c'est avoir une pièce unique, pleine de personnalité, saisissante de forme classique mais contemporaine. Point de convergence du design et de la maîtrise artisanale, générateur d'un objet unique d'une forte identité.

DE

Zeitlose Eleganz ist der Schlüssel zu zeitgenössischem Luxus als Lebensart und Modetrend. Luxus ist es ein einzigartiges, faszinierendes Objekt voller Persönlichkeit zu besitzen, das klassische, gleichzeitig jedoch moderne Formen aufweist. Durch die Konvergenz von Design und handwerklichem Können wurde ein einzigartiges Objekt mit starker Identität und offenem Erscheinungsbild geschaffen, das bezüglich Materialität und Designvokabular radikal reduziert wurde.

RU

Вневременная элегантность - ключ к современной роскоши как стилю жизни и тенденции в моде. Роскошь означает владеть уникальным, восхитительным предметом, полным индивидуальности, изделием с классическими формами, но в то же время современным. Слияние дизайнерской разработки с мастерством лучших ремесленных традиций, породивших уникальное изделие с сильным открытым характером.

DIMENSIONS:

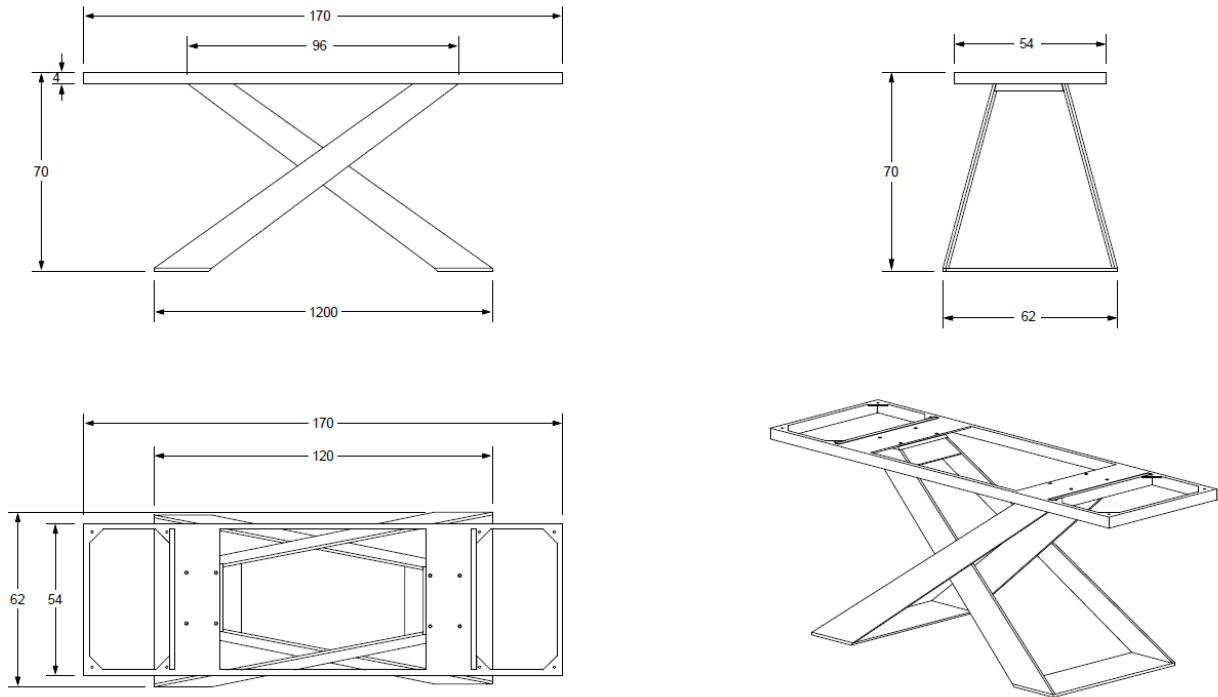

TOPS OPTIONS



Laquered / Laca / Laqué / Lack / Лакированный
Veneer / Чapa / Plaqué / Holzfurnier / Шпон



Solid / Macizo / Massif / Massiv / Массивный

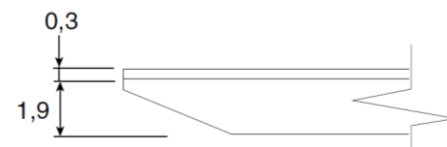

Ceramic / Cerámica / Céramique / Keramik / Керамика
(Hydra argen / Blaze dark / Kalos bianco)

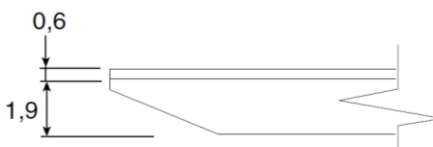

Ceramic / Cerámica / Céramique / Keramik / Керамика
(Calacatta / Pulpis / Urano)

Design	Cm	Inches
	200 x 100	78,74 x 39,37 x 7,48
	240 x 100	94,49 x 39,37 x 7,48
	240 x 120	94,49 x 47,24 x 7,48
	280 x 100	110,24 x 39,37 x 7,48
	280 x 120	110,24 x 47,24 x 7,48
	300 x 100	118,11 x 39,37 x 7,48
	300 x 120	118,11 x 47,24 x 7,48

Design	Cm	Inches
	200 x 100	78,74 x 39,37 x 7,48
	240 x 100	94,49 x 39,37 x 7,48
	240 x 120	94,49 x 47,24 x 7,48
	280 x 100	110,24 x 39,37 x 7,48
	280 x 120	110,24 x 47,24 x 7,48
	300 x 100	118,11 x 39,37 x 7,48
	300 x 120	118,11 x 47,24 x 7,48

FINISHES:

TOP

Lacquers



White / Blanco / Blanc



Pearl grey / Gris Perla / Gris Perle



Foggy



Rain



Slate / Pizarra / Ardoise



Stone / Piedra / Stone



Sahara



Mocca



Mink / Visón / Vison



Gold



Terracota / Terre Cuite



Brick



Merlot



Taupe



Black / Negro / Noir



Moss



Salvia



Whale blue / Azul Ballena / Bleu Baleine



Mustard / Mostaza / Moutarde



Navy



Coffee

Natural Veneers



European oak / Roble europeo / Chêne Européen



Leopard oak / Roble Leopard / Chêne Leopard



American walnut / Nogal Americano / Noyer Américain



Smoky oak / Roble Fumé / Chêne Fumé

Ceramics



Hydra Argen



Blaze Dark



Kalos Bianco



Ferox



Concerto



Calacatta 6mm.



Urano 6mm.

BASE

Lacquers

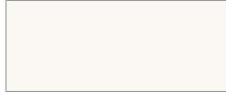

White / Blanco / Blanc

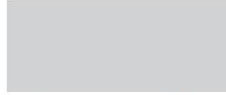

Pearl grey / Gris Perla / Gris Perle

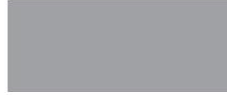

Foggy



Rain

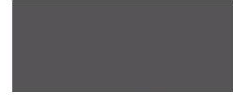

Slate / Pizarra / Ardoise



Stone / Piedra / Stone



Sahara



Mocca



Mink / Visón / Vison



Gold



Terracota / Terre Cuite



Brick



Merlot



Taupe



Black / Negro / Noir



Moss



Salvia



Whale blue / Azul Ballena / Bleu Baleine



Mustard / Mostaza / Moutarde



Navy



Coffee

Special Lacquers for metal tables



Blanco Epoxy



Champagne

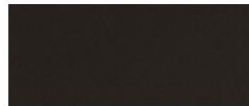

Graphite

DESIGNER:

Martín Consuegra



EN

Sculptor and designer born in 1957. In Toledo (Spain). He studied at San Fernando's faculty of Fine Arts, Madrid.

He moved to its current, Valencia city, where he studied at the National School of Ceramics in Manises.

In 1977 he opened his first sculpture and design studio. Making author work as a sculptor and industrial design projects and prototyping to mold development in sectors as diverse as ceramics, porcelain, glass, lighting, automation, plastic and in recent years, furniture.

SP

Escultor y diseñador nacido en el año 1957, en Toledo (España). Estudia en la facultad de Bellas Artes San Fernando de Madrid.

Se traslada a su ciudad actual, Valencia, y estudia en la Escuela Nacional de Cerámica de Manises.

En 1977 establece su primer estudio de escultura y diseño. Realizando obra de autor como escultor y proyectos de diseño industrial y prototipado para el desarrollo de moldes en sectores tan diversos como el de la cerámica, porcelana, vidrio, iluminación, automatización, plástico y en los últimos años, mueble.

FR

Sculpteur et designer, né en 1957 à Tolède (Espagne). Poursuit ses études dans la faculté de Beaux Arts de San Fernando à Madrid.

Il se déplace à Valence pour étudier dans L'Ecole Nationale de céramique de Manises.

En 1977 il a Établi son premier studio de sculpture et design. Il Réalise des œuvres d'Auteur comme sculpteur et développe des projets de design industriel et fait les prototypes pour le développement de moules dans les secteurs aussi divers comme la céramique, la porcelaine, le verre, l'éclairage, le plastique et dans les dernières années le mobilier.

DE

Bildhauer und Designer, geboren 1957 in Toledo (Spanien). Studium an der Fakultät für schöne Künste San Fernando in Madrid.

Danach zog er nach Valencia um, wo er heute lebt, und wo er an der Nationalen Keramikscheule von Manises studierte.

1977 gründete er sein erstes Bildhaueri- und Designstudio. Er arbeitet als Bildhauer und Industriedesigner.

Er baut ebenfalls Prototypen für die Entwicklung von Formen in so unterschiedlichen Bereichen wie Keramik, Porzellan, Glas, Beleuchtung, Automatisierung, Kunststoff und, in den letzten Jahren, Möbel.

RU

Скульптор и дизайнер, он родился в 1957 году в Толедо (Испания). Снала он учится на факультете изобразительных искусств Сан-Фернандо-де-Мадрид.

Затем он переезжает в свой нынешний город, Валенсия, и учится в Национальной школе керамики Манисес.

В 1977 году он основал свою первую студию скульптуры и дизайна. Создает авторские работы в качестве скульптора, а также проекты промышленного дизайна и прототипирования для разработки пресс-форм в таких разнообразных секторах, как керамика, фарфор, стекло, освещение, автоматизация, пластик и в последние годы мебель.