

ALMA light

**ALMA** light  
Barcelona

Catálogo general

***General catalogue***

2023

V02-23

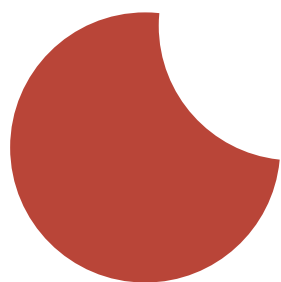



ALMA light  
Barcelona

# Quién es

Josep Novell (Barcelona 1953)

Oriol Llahona (Barcelona 1977)

Ernest Perera (Barcelona 1974)

Jordi Llopis (Barcelona 1972)



## Josep Novell.

Estudia Diseño de Producto en ELISAVA (Escuela Universitaria de Diseño e Ingeniería de Barcelona), y posteriormente se gradúa en Bachelor of Arts por la University of Southampton (Reino Unido). Desde 1980 se dedica al diseño, tanto desde su propio estudio como en colaboración con otros diseñadores. En 1984 funda la empresa "Via Design", junto con Joan Suñol, proyecto que finaliza en 1988. Posteriormente crea "Novell/Puig Design" junto con el diseñador Josep Puig. Además, desde 1984 imparte clases como profesor de proyectos en la Escuela Superior de Diseño ELISAVA. Es miembro de la Asociación de Diseño Industrial del Foment de les Arts i del Disseny (ADI-FAD). Para ALMA LIGHT, conjuntamente con los diseñadores Josep Puig y Ernest Perera, ha desarrollado luminarias clásicas de la marca, como las colecciones BLOW, FLAT, MOON, ORB, ROOM, STONE, SUN y TINY.

Josep Novell está particularmente interesado en relacionar estrechamente tres conceptos: forma, material y proceso de fabricación. Además tiene muy en cuenta aspectos más intangibles del producto como la comunicación, la emoción o la ética. Sus diseños están presentes en ámbitos tan diferentes como la iluminación, el packaging, el diseño de producto, el mobiliario o la imagen corporativa. Josep Novell es uno de los grandes diseñadores de nuestro país, y muchas de sus creaciones han sido galardonadas y expuestas en ferias y certámenes de diseño en Europa, Estados Unidos y Asia.

## Oriol Llahona.

Estudia Diseño Industrial en, Barcelona, Alemania y Reino Unido. Se gradúa en

1999 y obtiene su postgrado en 2004. Después de trabajar en diversas empresas y estudios de diseño, en 2004 crea su propio proyecto llamado "Llahona Design Studio" en el cual desarrolla su visión cosmopolita, contemporánea y positiva del diseño, la búsqueda de la esencia y las emociones en nuestra vida. En 2012 es llamado a unirse a Philips, diseñando luminarias de origen y asumiendo su Dirección Creativa. Actualmente trabaja en varios proyectos en Europa, América y Asia que incluyen diseños de iluminación, muebles y electrónica de consumo. Para ALMA LIGHT ha desarrollado luminarias que ya se han convertido en clásicos, como las colecciones BATH, BIG BROTHER, CAPITONÉ, MADAME, NOTE, PROFILE, SPIKE y SUIT.

Oriol Llahona es un diseñador nato, curioso y de mente abierta, su estilo es una mezcla de búsqueda de nuevos materiales y tecnologías con un sereno y refinado sentido de las formas. Sus diseños abarcan ámbitos tan diversos como la iluminación, el packaging, el diseño de producto, los espacios de restauración, el mobiliario. Muchas de sus creaciones han sido expuestas en salones de Italia, Alemania y Japón y han sido seleccionadas para diversas publicaciones sobre diseño internacional.

## Ernest Perera.

Ernest Perera combina sus estudios de escultura en la Facultad de Bellas Artes de la Universidad de Barcelona con los de Diseño Industrial en la Escuela ELISAVA (Escuela Universitaria de Diseño e Ingeniería) de la misma

ciudad.

Funda su propio estudio en 1999, donde diseña productos y experiencias para ayudar a las empresas a ser más competitivas, desde piezas únicas a elementos altamente seriados. Sus trabajos se caracterizan por proporcionar conceptos renovados en cada proyecto, aportando soluciones específicas para cada caso. En 2006 crea "Amor de Madre", su propia empresa editora de productos para el hogar, la cual le permite imprimir su libertad de creación y de experimentación en diversos productos del ámbito del hogar. Desde 1998 es docente en varias universidades de diseño de Barcelona. Actualmente es el Jefe de Área de Diseño de Productos en la escuela LCI Barcelona.

Ha colaborado con empresas como Camper, Lékué, Delica, Mago Urban, Alma Light –donde desarrolla junto a Josep Novell las colecciones BLOW, FLAT, MOON, ORB, PILL y SQUARE--, Museo Picasso de Barcelona, Rumitag, Artesanía de Cataluña o el ADI-FAD. Ha recibido diversos galardones, como una selección a los Premios DELTA de Diseño ADI-FAD, Barcelona (2009) y el primer premio en el certamen internacional Les Découvertes, Maison Objet, París (2008).

Sus creaciones han sido expuestas en galerías de todo el mundo y han sido seleccionadas para diversas publicaciones sobre diseño internacional.

## Jordi Llopis.

Se forma como diseñador en la Escuela ELISAVA de Barcelona y en el "Royal College of Art" de Londres.

Diseñador Industrial, ha trabajado como Design Manager en empresas de iluminación, llevando a cabo la dirección de nuevos productos e identidad corporativa. Lleva años colaborando con empresas de iluminación, mobiliario urbano y objetos para el hogar. 'Lifelight', lámpara creada por él en 2003, forma parte de la colección permanente del 'Museu del Disseny' de Barcelona, y su lámpara 'Clipa'm' fue seleccionada en los Premios Delta 2016.

Actualmente dirige su propio estudio de diseño llamado Jordi Llopis Design, en Barcelona, y es co-fundador de la editora Brots. Trabaja desarrollando nuevos diseños para el mundo de la iluminación y elementos urbanos, así como diseñando y produciendo sus nuevas colecciones para Brots. La excusa es diseñar para uno mismo como autoencargo, sin premisas ni filtros previos, para poder llegar a un producto muy personal, original y coherente que ofrecer. Esta es parte de la filosofía que se quiere transmitir en Brots. Jordi Llopis colabora, además, como profesor externo en ESDI, Escuela Superior de Diseño de Barcelona y ELISAVA Alumni y es tutor en el Máster de ESdesign Barcelona. Ha sido jurado en los Premios Eil de ELISAVA de Barcelona, y ha impartido talleres en la Universidad de Aguascalientes en México y en ELISAVA.

# Who is

Jordi Llopis (Barcelona 1972) Ernest Perera (Barcelona 1974) Oriol Llahona (Barcelona 1977) Josep Novell (Barcelona 1953)

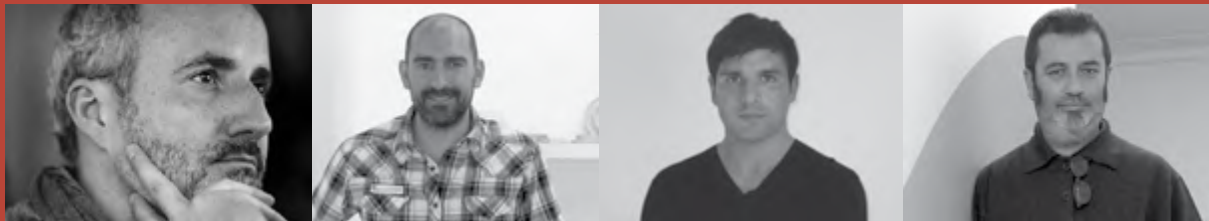

*Ernest Perera.*

*He combined his studies of sculpture in the Faculty of Fine Arts of the University of Barcelona with those of Industrial Design in ELISAVA (University School of Design and Engineering) of the same city. He founded his own studio in 1999, where he designed products and experiences to help companies become more competitive, from unique pieces to highly serialized elements. His works are characterized by providing renewed concepts in each project, bringing specific solutions for each case. In 2006, he created "Amor de Madre", his own company for home products, which allows him to develop his freedom of creation and experimentation on various household products. Since 1998 he has been teaching at several design universities in Barcelona. He is currently the Head of Product Design at LCI Barcelona School. He has collaborated with companies such as Camper, Llékué, Delica, Mago Urban, ALMA LIGHT - where he developed, together with Josep Novell, the collections BLOW, FLAT, MOON, ORB, PILL and SQUARE--, Barcelona Picasso Museum, Rumitag, Artesanía de Cataluña or the ADI-FAD. He has received several awards, such as a selection at the DELTA Design Awards ADI-FAD, Barcelona (2009) and the first prize at the international competition Les Découvertes, Maison Objet, Paris (2008). His creations have been exhibited in galleries around the world and have been selected for various publications on international design.*

*Jordi Llopis*

*was formed as a designer at the ELISAVA School in Barcelona and at the 'Royal College of Art' in London. Industrial Designer, he has worked as a Design Manager in lighting companies carrying out the direction of new products and corporate identity. He has been collaborating with lighting companies, street furniture and household items for years. 'Lifelight', a lamp created by him in 2003, is part of the permanent collection of the 'Museu del Disseny' of Barcelona, and the 'Clipa'm' lamp was selected in the Delta 2016 Awards. He currently directs his own design studio called Jordi Llopis Design, in Barcelona, and is co-founder of the editing company Brots. He works developing new designs in the world of lighting and urban elements, as well as designing and producing new collections for Brots. The excuse is to design for oneself on self-request, without prejudices or previous filters, in order to arrive at a very personal, original and coherent product to offer. This is part of the philosophy that to be transmitted by Brots. Jordi Llopis also collaborates as an external teacher at ESDI, Barcelona School of Design and ELISAVA Alumni and is Tutor in the ESdesign Barcelona Master. He has been a jury at the Ei Awards! of ELISAVA in Barcelona, and has collaborated in workshops at the University of Aguascalientes in Mexico and in ELISAVA.*

*Oriol Llahona.*

*He studied Industrial Design in Barcelona, Germany and the United Kingdom. He graduated in 1999 and obtained his postgraduate degree in 2004. After working in various companies and design studios, in 2004 he created his own project called "Llahona Design Studio" in which he developed his cosmopolitan, contemporary and positive vision of design, the pursuit of essence and emotions in our life. In 2012 he was called to join Philips, designing light fixtures and undertaking his Creative Direction. He is currently working on several projects in Europe, America and Asia including lighting designs, furniture and consumer electronics. For ALMA LIGHT has developed luminaires that have already become classics, such as BATH, BIG BROTHER, CAPITONÉ, MADAME, NOTE, PROFILE, SPIKE and SUIT. Oriol Llahona is a born designer, curious and open-minded, his style is a mixture of searching for new materials and technologies with a serene and refined sense of forms. His designs cover areas as diverse as lighting, packaging, product design, dining spaces, furniture. Many of his creations have been exhibited in salons in Italy, Germany and Japan. They have also been selected for various publications on international design*

*Josep Novell.*

*He studied Product Design at ELISAVA (School of Design and Engineering of Barcelona) and he later graduated as Bachelor of Arts at the University of Southampton (United Kingdom). Since 1980 he has been dedicated to design, both from his own studio and in collaboration with other designers. In 1984 he founded the company "Via Design, SA" together with Joan Suñol, a project that ended in 1988. He later created "Novell / Puig Design" together with the designer Josep Puig. In addition, since 1984 teaches as a professor of projects in the School of Design ELISAVA. He is a member of the Industrial Design Association of the Foment de les Arts i del Disseny (ADI-FAD). In ALMA LIGHT, together with the designers Josep Puig and Ernest Perera, he has developed classic luminaires of the brand such as the collections BLOW, FLAT, MOON, ORB, ROOM, STONE, SUN and TINY. Josep Novell is particularly interested in closely relating three concepts: form, material and manufacturing process. He also takes into account more intangible aspects of the product such as communication, emotion or ethics. His designs are present in areas as different as lighting, packaging, product design, furniture or corporate image. Josep Novell is one of the great designers of our country, and many of his creations have been awarded and exhibited in fairs and design contests in Europe, the United States and Asia.*

# Ilumínate

Obj (Barcelona 2007)

Josep Puig (Barcelona 1959)

Cristian Cubiñá (Barcelona 1968)

Alfonso de la Fuente (Valladolid 1974)

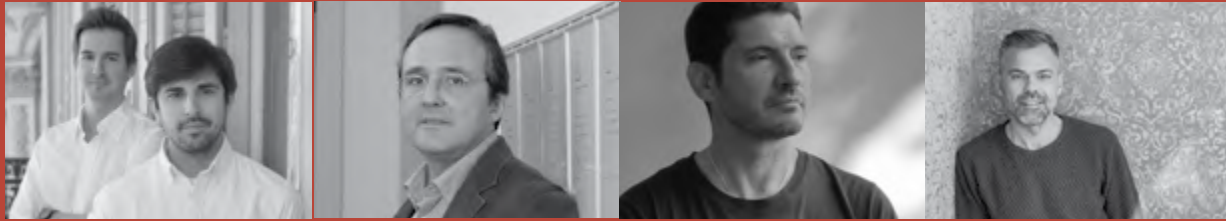

## Obj ( Javier Taberner & Nacho Poveda )

Nace en 2007 de la unión de sus dos socios: Javier Taberner y Nacho Poveda. Sus diseños de mobiliario, producto e iluminación han sido reconocidos con numerosos premios y distinciones, habiendo sido difundidos en publicaciones especializadas a nivel internacional. El estudio también ha participado en distintas exposiciones y eventos en diferentes ciudades de Iberoamérica, Londres, Madrid, Milán, Barcelona, Saint Étienne, etc.

## Josep Puig

Estudia Diseño Industrial en ELISAVA (Escuela Universitaria de Barcelona Diseño e Ingeniería) y obtiene el título en 1980. Posteriormente amplía su formación en la University of Southampton (Reino Unido) donde se gradúa con honores como Bachelor of Arts. Es miembro de la Asociación de Diseño Industrial del Fomento de las Artes y el Diseño ADI-FAD y ha formado parte de la Junta de la Asociación en diversas ocasiones. Ha impartido cursos y talleres en numerosos foros de diseño y actualmente es profesor en la Escuela Superior de Diseño ELISAVA, donde dirige el Máster en Diseño y Desarrollo de Producto en ELISAVA desde 2006. Josep Puig es un diseñador inquieto y brillante cuya creatividad se ha desarrollado en multitud de ámbitos. Entre otras muchas iniciativas, es miembro fundador del grupo de diseño experimental "Transatlàntic" junto a Ramón Benedito y Lluís Morillas. En 1989 se embarca en el proyecto "The Barna Crossing in Fukuoka" con Alfredo Arribas Arquitectos Asociados, para el diseño de una colección de objetos para un complejo multimedia en Fukuoka (Japón). Durante su trayectoria profesional

ha recibido numerosos premios y distinciones de organismos españoles e internacionales. Junto al diseñador Josep Novell funda en 1992 el estudio "Novell/Puig Design", orientado al diseño y desarrollo de productos. En 2010 crea su propio estudio "Puig[i]Cabeza Design". Para ALMA LIGHT ha desarrollado, junto con Josep Novell, colecciones de luminarias ya clásicas de la marca como STONE, SUN y TINY. Sus diseños, numerosos de ellos premiados en certámenes nacionales e internacionales, abarcan áreas tan variadas como los artículos sanitarios, gafas, packaging, cerámica y vidrio, electrodomésticos, mobiliario, iluminación y menaje del hogar.

## Cristian Cubiñá

Estudia Diseño Industrial en la Escuela ELISAVA (Escuela Universitaria de Diseño e Ingeniería) de Barcelona y una vez finaliza su formación decide crear su proyecto empresarial, fundando la sociedad familiar "Hustadt Iluminación". Durante los primeros años asume las responsabilidades de Jefe de Producto. En 2003, momento en que la compañía crea la marca ALMA LIGHT, se responsabiliza de áreas más amplias como diseño de producto, selección de proveedores de proximidad y control de la fabricación y de sus estándares de máxima calidad, siempre con la vista puesta en la continua evolución del mercado, tanto en términos de diseño como en aspectos puramente tecnológicos y productivos. Es en el proyecto ALMA LIGHT donde Cristian Cubiñá puede desarrollar sus dotes de diseñador, proyectando los stands de las ferias a las que la empresa acude como expositora, y creando colecciones ya clásicas como la DROP o la LENS. Más adelante firmará otras

creaciones, como las familias CANDLE, CAPSULE, DECO, HOTEL, KONE, LED BOX, LED OVAL, LED POLE, THE LIGHT y THE PALM. Sus diseños están impregnados de su carácter curioso y observador y en su afán por fijarse en todo lo que ve a su alrededor, donde cualquier detalle puede ser susceptible de convertirse en una luminaria.

Cristian Cubiñá es uno de los diseñadores más reputados en el campo de la iluminación decorativa contemporánea, sector en el cual está especializado. Sus creaciones han sido expuestas en diversas ferias europeas y han sido seleccionadas para diversas publicaciones sobre diseño internacional.

## Alfonso de la Fuente (Pichiglas Studio)

Afincado en Barcelona desde 1997, Alfonso de la Fuente ha ido evolucionando como artista autodidacta, aportando aires de renovación al panorama del diseño en el ámbito de la decoración a base de trabajo, talento, pasión e imaginación. Después de que su llegada a Barcelona le descubriese el reciclaje del plástico, Pichiglas empieza a reutilizar botellas de consumo masivo para crear objetos, creando su primer aparato de iluminación decorativa en 1997. Pichiglas se desarrolla entonces a gran velocidad gracias a la continua creatividad, a la pasión y al trabajo, produciendo siempre con humor, ironía y color, y convirtiéndose en partícipe de esa Barcelona tan de moda de los primeros años del siglo XXI en la que todo era posible. Después de cosechar un notable éxito con su línea de objetos decorativos y accesorios, el diseñador decide incluir en sus intereses el interiorismo integral para la decoración de bares de moda, restaurantes, comercios, locales y clubs, algunos convertidos ya en grandes clásicos como la discoteca barcelonesa FONFONE. El trabajo de Pichiglas Studio se da a conocer ya no sólo a nivel nacional, sino que empieza a recibir encargos de países como Francia e Italia. Lo que diferencia a Pichiglas Studio del resto de diseñadores es, precisamente, su capacidad para hacer de las texturas, los materiales y los objetos cotidianos verdaderas combinaciones de efectos visuales que no dejan a nadie indiferente. En una época en la que triunfa el minimalismo, Alfonso de la Fuente y Pichiglas Studio, revolucionan la decoración de los espacios con un denominador común: explosión de color combinada con una sorprendente simplicidad conceptual que consiguen un resultado de alto poder expresivo. En palabras del propio diseñador, "Hoy en día, tenemos que contar cosas cuando creamos, sorprender y chocar, pero sin perder nuestra esencia, aquello que nos define"

# Light up

Alfonso de la Fuente (Valladolid 1974) Cristian Cubiñá (Barcelona 1968)

Josep Puig (Barcelona 1959)

Obj (Barcelona 2007)

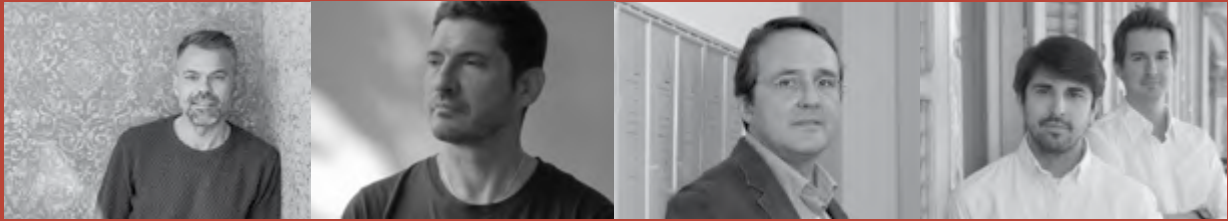

DROP or LENS. Later, he signs other creations such as CANDLE, CAPSULE, DECO, HOTEL, KONE, LED BOX, OVAL LED, LED POLE, THE LIGHT and THE PALM. His designs are imbued with his curious and observant character and his eagerness to look at everything he sees around him, where any detail can be susceptible of becoming a light fitting.

Cristian Cubina is one of the most renowned designers in the field of contemporary decorative lighting, a sector in which he is specialized. His creations have been exhibited at various European fairs and have been selected for several publications on international design.

#### Alfonso de la Fuente (Pichiglas Studio)

Based in Barcelona since 1997, Alfonso de la Fuente has evolved as a self-taught artist, bringing renewal airs to the design environment in the field of decoration based on work, talent, passion and imagination.

After his arrival in Barcelona, when finding out more about the recycling of plastic, Pichiglas begins to reuse bottles of mass consumption to create objects, designing his first decorative lighting fixture in 1997. Pichiglas develops then at high speed thanks to his continuous creativity, passion and work, always producing with humor, irony and color, and becoming a participant in that fashionable Barcelona of the first years of the 21st century in which everything was possible.

After reaping a remarkable success with his line of decorative objects and accessories, the designer decides to include in his interests the integral interior design for the decoration of trendy bars, restaurants, shops, stores and clubs, some of which have already become great classics such as the Barcelona disco FONFONE. The work of Pichiglas Studio is already known not only nationally, but begins to receive orders from countries such as France and Italy. What sets Pichiglas Studio apart from other designers is precisely its ability to make textures, materials and everyday objects true combinations of visual effects that leave no one indifferent. In an era in which minimalism triumphs, Alfonso de la Fuente and Pichiglas Studio revolutionize the decoration of spaces with a common denominator: explosion of color combined with a surprising conceptual simplicity that achieve a result of high expressive power.

In the words of the designer himself: "Today, we have to tell things when we create, we must surprise and collide, but without losing our essence, what defines us."

Japan. During his professional career he has received numerous awards and distinctions from Spanish and international organizations. Together with the designer Josep Novell founded in 1992 the study "Novell / Puig Design", oriented to the design and development of products. In 2010 he created his own studio "Puig [i] Cabeza Design". For ALMA LIGHT has developed, along with Josep Novell, collections of classic luminaires of the brand as STONE, SUN and TINY. Its designs, many of them awarded in national and international competitions, cover areas as varied as sanitary ware, glasses, packaging, ceramics and glass, household appliances, furniture, lighting and household items.

#### Cristian Cubiñá.

He studies Industrial Design at the ELISAVA School (University School of Design and Engineering) in Barcelona and, once he finishes his training, he decides to create his own business project, founding the family society "Hustadt Iluminación".

During the first years he undertakes the responsibilities of Product Manager.

In 2003, when the company creates the ALMA LIGHT brand, he becomes responsible for broader areas such as product design, selection of proximity suppliers and control of manufacturing and its highest quality standards, always with a view to the evolution of the market, both in terms of design and purely technological and productive aspects. It is in the ALMA LIGHT project that Cristian Cubina can develop his skills as a designer, projecting the stands of the fairs in which the company participates as exhibitor and creating classic collections, such as

#### Obj ( Javier Taberner & Nacho Poveda )

Studio borned in 2007 from the union of his two partners: Javier Taberner and Nacho Poveda. Their designs of furniture, product and lighting have been recognized with numerous prizes and distinctions in specialized publications, having spread to an international level. The studio also has participated in different exhibitions and events in different cities of Ibero-America, London, Madrid, Milan, Barcelona, Saint Étienne, etc.

#### Josep Puig Cabeza.

He studied Industrial Design at ELISAVA (Escuela Universitaria de Barcelona Diseño y Ingeniería) and obtained his degree in 1980. He later completed his degree at the University of Southampton (UK) where he graduated with honors as a Bachelor of Arts. He is a member of the Industrial Design Association of the Promotion of Arts and Design ADI-FAD and has been part of the Board of the Association on several occasions. He has taught courses and workshops in numerous design forums and is currently a professor at ELISAVA, where he has been leading the Master in Design and Product Development since 2006.

Josep Puig is a restless and brilliant designer whose creativity has developed in many areas. Among other initiatives, he is a founding member of the experimental design group "Transatlàntic" with Ramón Benedito and Lluís Morillas. In 1989 he embarked on the project "The Barna Crossing in Fukuoka" with "Alfredo Arribas Arquitectos Asociados", for the design of a collection of objects for a multimedia complex in Fukuoka,

# Luminarias USB

# USB Lamps

Bell / Cuadrat / Nautic / Patio / Tribeca USB











## Tribeca USB

Design by Jordi LLopis

Pantalla alabastro  
**Shade alabaster**

Estructura hierro galvanizado pintado epoxi texturizado  
**Structure galvanized iron textured epoxy painted**

Luminaria con batería de polímero de Litio. Autonomía 7h, carga completa 5h. Cargador USB, entrada tipo Micro-B no incluido (ver referencias abajo). Led integrado. ON/OFF/Touch dimmer  
**Lithium polymer battery 7h autonomy. Complete charge 5h. USB charger, port type Micro-B not included (See codes below). Integrated Led. ON/OFF/Touch Dimmer**

1800/011 24cm blanco texturizado **textured white**

1800/012 24cm corten texturizado **textured corten**

1800/018 24cm negro texturizado **textured black**

1810/011 20cm blanco texturizado **textured white**

1810/012 20cm corten texturizado **textured corten**

1810/018 20cm negro texturizado **textured black**

LED 1,3W 150lm 3000K

9995/010 Cargador USB simple 5V 2A + cable USB de 1,5mt entrada tipo Micro-B **Single 5V 2A charger + 1.5m USB cable port type Micro-B**

9996/060 Cargador múltiple 5V 12A + 6 x cable USB de 1,5mt entrada tipo Micro-B **Multiple charger 5V 12A + 6 x 1.5m USB cable port type Micro-B**

CE  

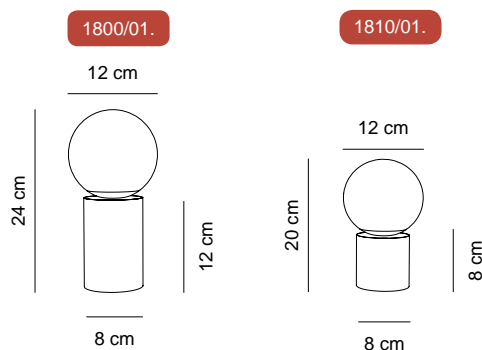

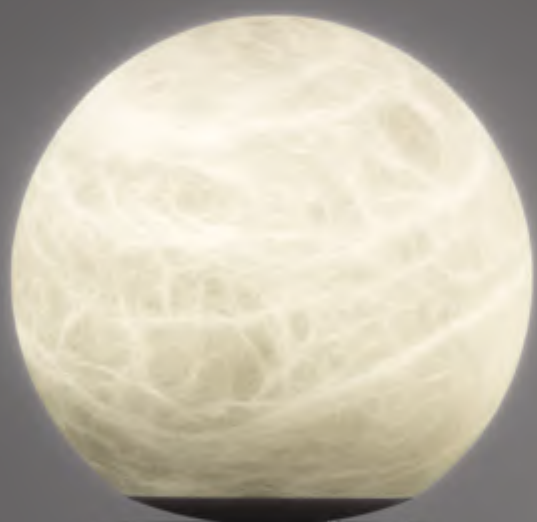









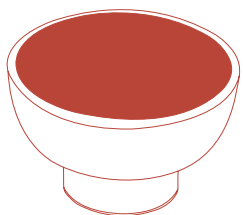

**Elegante / Funcional**  
**Fashionable / Useful**



Los acabados de la luminaria PATIO, así como su diseño sereno y nada estridente, le confieren una gran elegancia aparte de su funcionalidad, al poderse colocar en cualquier sitio independientemente de tener una toma de corriente cercana. El difusor está fabricado en polietileno rotomoldeado en color natural y el cuerpo es de aluminio arenado y anodizado, disponible en dos versiones: plata y oro.

*The finishes of the PATIO lamp, as well as its serene and smart design, give it great elegance apart from its functionality, as it can be placed anywhere regardless of having a plug nearby. The diffuser molded polyethylene in natural color and the body is made of sandblasted and anodized aluminium, available in two versions: silver and gold.*

Se puede suministrar:

- Sin cable cargador (se puede usar el de un teléfono móvil).
- Con 1 cargador y 1 cable USB para 1 luminaria.
- Con 1 cargador múltiple con 6 cables USB para cargar simultáneamente 6 luminarias.

*It can be ordered:*

- *Without charger (the charger from a mobile phone can be used).*
- *With 1 charger and 1 USB cable for 1 lamp*
- *With 1 multiple charger and 6 USB cables to simultaneously charge 6 lamps.*





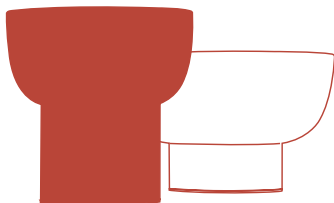

## Usb / Inalámbrico *Usb / Wireless*



PATIO es una luminaria sin cables pensada para iluminar una mesa, ya sea en interior como en exterior, sin necesidad de disponer de una toma de corriente. Una aplicación ideal para hostelería y hotelería.

Utiliza una fuente de luz LED de 3W con un rendimiento máximo de 260 lúmenes. Gracias a su pantalla en polietileno rotomoldeado, esta luz se disipa homogéneamente iluminando el espacio sin sombras y la cubierta de aluminio anodizado evita el deslumbramiento de los comensales. Dispone de una batería de li-ion que permite una autonomía de máxima de 17 horas que se carga mediante un conector Micro USB (igual que el de un teléfono móvil) situado en la base. También dispone de un pulsador de encendido y apagado con tres posiciones de encendido, para ajustar la luz según la necesidad de cada momento. La base dispone de unos topes de silicona para evitar que la luminaria se deslice, en caso que la superficie de apoyo no sea estable, como en caso de barcos o autocaravanas.



*PATIO is a wireless lamp ideal for installations, designed to illuminate a table, either indoors or outdoors, without the need of a plug. Perfect for its use in hotels, restaurants, terraces...*

*It uses a 3W LED light source with a maximum output of 260 lumens. Thanks to its polyethylene rotomolded shade, the light is dissipated evenly illuminating the space without shadows and the aluminium cover prevents the glare to the people sitting around the table. It houses a li-ion battery that allows 17 hours of authonomy, that is charged with a USB charger (like the ones used for mobile phones) located at the base. Besides it has an on-off switch with three positions to adjust the light according to the needs of each moment. The base has silicone stoppers to prevent the luminaire to slide, in case the surface is not stable, as in boats or mobile homes.*





## Patio

Design by Oriol LLahona

Pantalla polietileno rotomoldeado  
**Shade molded polyethylene**

Estructura aluminio anodizado  
**Structure anodized aluminium**

Luminaria con batería Li-ion. Autonomía intensidad baja 17h, intensidad media 7h, intensidad alta 4h. Carga completa 8h. Cargador USB, entrada tipo Micro-B no incluido (ver referencias abajo).

Led integrado. ON/OFF dimmer 3 posiciones.

**Lit-ion battery lamp. low intensity 17h, medium intensity 7h, high intensity 4h Total charge 8h. USB charger, port type Micro-B not included (See codes below). Integrated Led. ON/OFF 3 steps Dimmer**

2000/010 16,50cm dorado mate **matt gold**

2000/016 16,50cm plata mate **matt silver**

2010/010 12,50cm dorado mate **matt gold**

2010/016 12,50cm plata mate **matt silver**

LED 5V 1.2A - max.3W 260lm 3000K

9995/010 Cargador USB simple 5V 2A + cable USB de 1,5mt entrada tipo Micro-B **Single 5V 2A charger + 1.5m USB cable port type Micro-B**

9996/060 Cargador múltiple 5V 12A + 6 x cable USB de 1,5mt entrada tipo Micro-B **Multiple charger 5V 12A + 6 x 1.5m USB cable port type Micro-B**

CE  IP 44

2010/010  
2010/016

2000/010  
2000/016

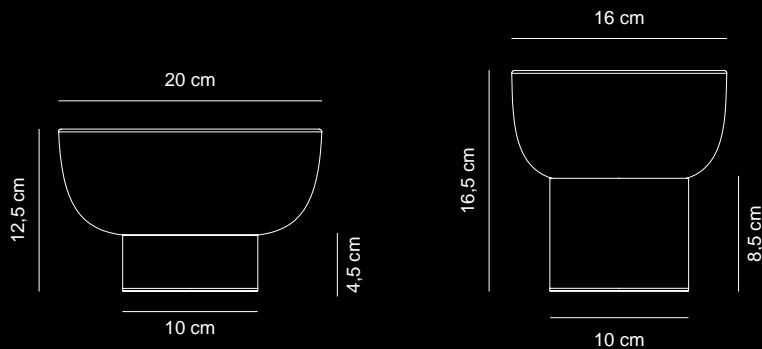







## Bell

Design by Cristian Cubiñá

Pantalla de latón arenado  
**Shade sandblasted brass**

Estructura madera maciza de Iroco  
**Structure massive Iroco wood**

Luminaria con batería de polímero de Litio. Autonomía 7h, carga completa 5h. Cargador USB, entrada tipo Micro-B no incluido (ver referencias abajo).  
Led integrado. ON/OFF/Touch dimmer  
**Lithium polymer battery 7h autonomy. Complete charge 5h. USB charger, port type Micro-B not included (See codes below).  
Integrated Led. ON/OFF/Touch Dimmer**

2050/010 redondo **round**

LED 1,3W 150lm 3000K

9995/010 Cargador USB simple 5V 2A + cable USB de 1,5mt entrada tipo Micro-B **Single 5V 2A charger + 1.5m USB cable port type Micro-B**

9996/060 Cargador múltiple 5V 12A + 6 x cable USB de 1,5mt entrada tipo Micro-B **Multiple charger 5V 12A + 6 x 1.5m USB cable port type Micro-B**

CE  IP 45

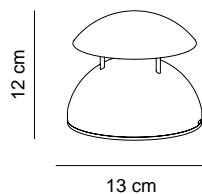

















## Cuadrat

Design by Josep Novell & Ernest Perera

Pantalla polietileno rotomoldeado

**Shade textured rotomoulded polyethylene**

Estructura de hierro pintado texturizado

**Structure textured epoxy painted iron**

Luminaria con batería de polímero de Litio. Autonomía 7h, carga completa 5h. Cargador USB, entrada tipo Micro-B no incluido (ver referencias abajo). Led integrado. ON/OFF/Touch dimmer

**Lithium polymer battery 7h autonomy. Complete charge 5h. USB charger, port type Micro-B not included (See codes below). Integrated Led. ON/OFF/Touch Dimmer**

2160/011 blanco texturizado **textured white**

2160/012 corren texturizado **textured corten**

2160/018 antracita texturizado **textured anthracite**

LED 1,3W 150lm 3000K

9995/010 Cargador USB simple 5V 2A + cable USB de 1,5mt entrada tipo Micro-B **Single 5V 2A charger + 1.5m USB cable port type Micro-B**

9996/060 Cargador múltiple 5V 12A + 6 x cable USB de 1,5mt entrada tipo Micro-B **Multiple charger 5V 12A 6 x 1.5m USB cable port type Micro-B**

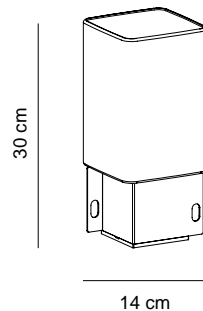

CE  IP 45









## Nautic

Design by Josep Novell & Ernest Perera

Pantalla polietileno rotomoldeado

**Shade textured rotomoulded polyethylene**

Estructura de aluminio pintado texturizado

**Structure textured epoxy painted aluminium**

Luminaria con batería de polímero de Litio. Autonomía 7h, carga completa 5h. Cargador USB, entrada tipo Micro-B no incluido (ver referencias abajo). Led integrado. ON/OFF/Touch dimmer

**Lithium polymer battery 7h autonomy. Complete charge 5h. USB charger, port type Micro-B not included (See codes below). Integrated Led. ON/OFF/Touch Dimmer**

5210/011 blanco texturizado **textured white**

5210/012 corten texturizado **textured corten**

5210/018 antracita texturizado **textured anthracite**

LED 1,3W 150lm 3000K

9995/010 Cargador USB simple 5V 2A + cable USB de 1,5mt entrada tipo Micro-B **Single 5V 2A charger + 1.5m USB cable port type Micro-B**

9996/060 Cargador múltiple 5V 12A + 6 x cable USB de 1,5mt entrada tipo Micro-B **Multiple charger 5V 12A + 6 x 1.5m USB cable port type Micro-B**

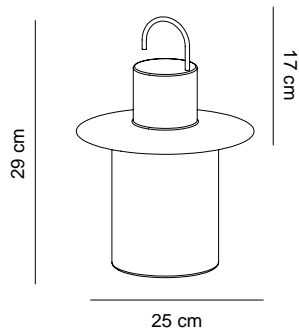

CE  IP 45



# Sobremesas Table Lamps

Aspen / Blow / Candle / Deco / Fuji / Hotel / Paros Alabaster / Star /  
Tribeca



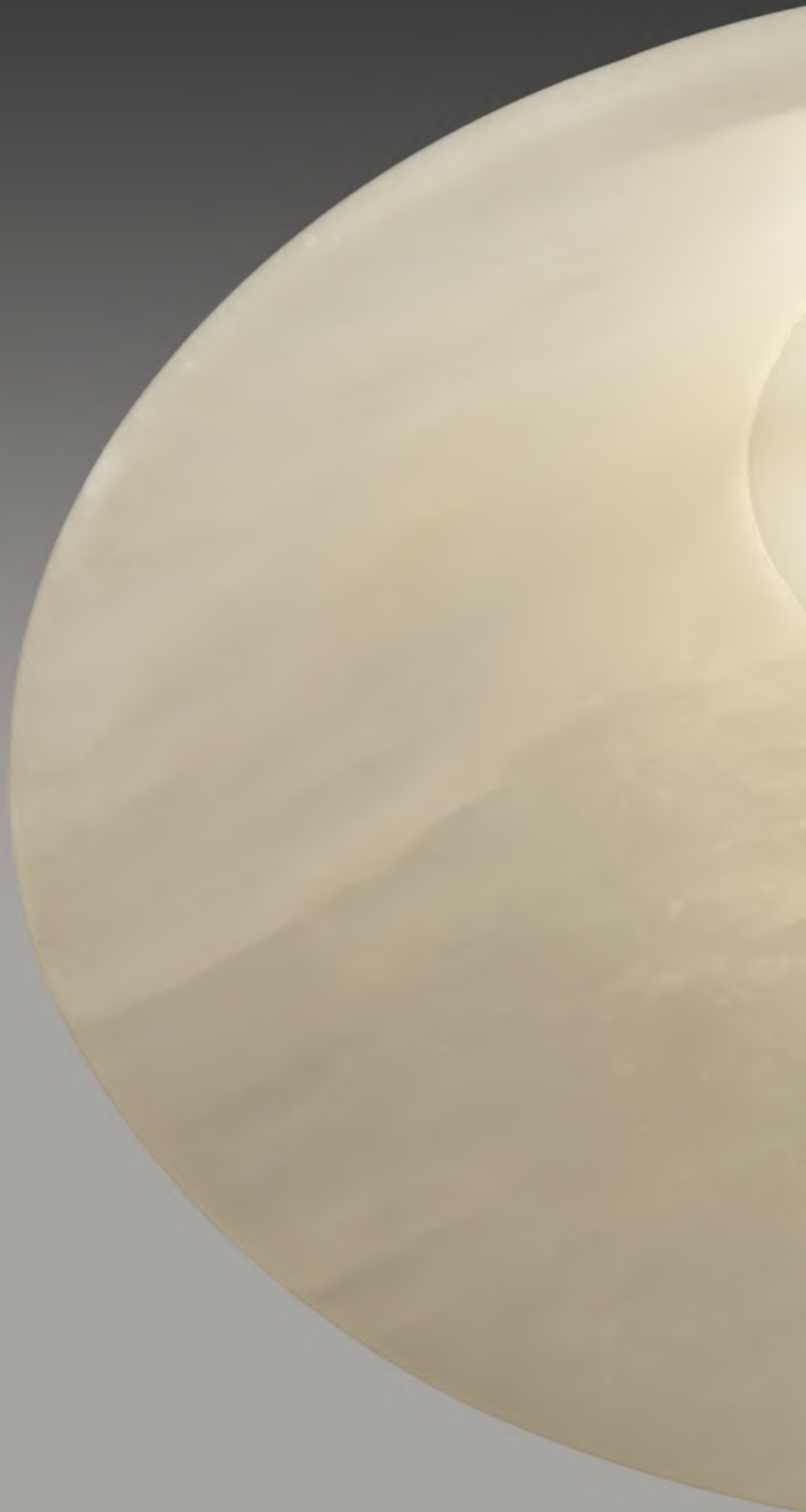



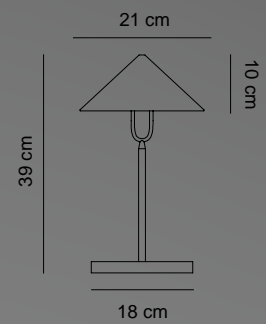

## Fuji

Design by Jordi LLopis

Pantalla alabastro  
**Shade alabster**

Estructura hierro baño electrolítico latón pulido  
brillo  
**Structure iron with electrolytic bath in polis-  
hed brass finish**

Sin regulador. Versión dimable bajo pedido  
**Without dimmer. Dimmable version upon  
request**

Led integrado  
**Integrated Led**

2070/010

LED Seoul 4,6W 260lm 2700K

CE  







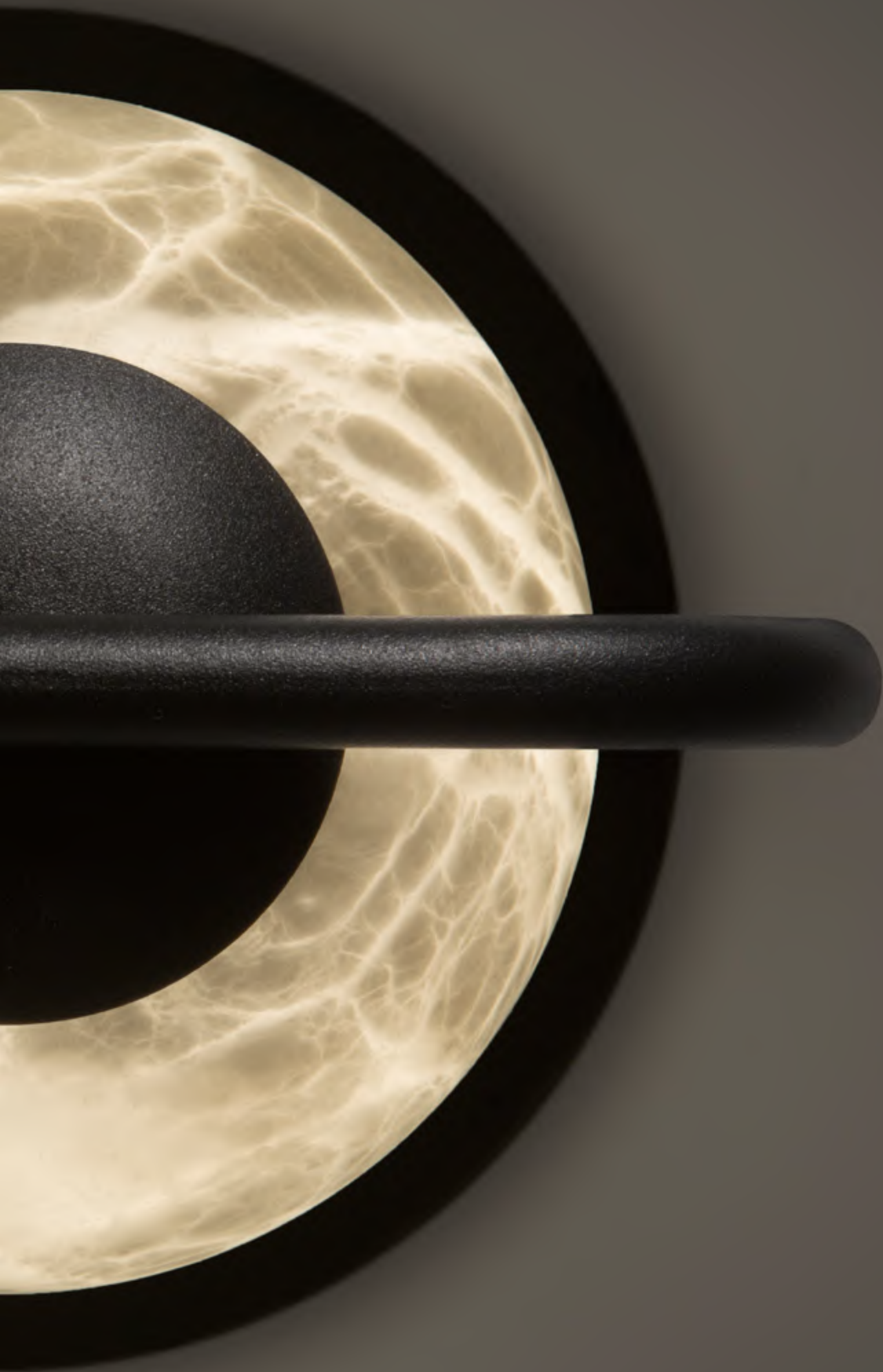



## Tribeca

Design by Jordi LLopis

---

Pantalla alabastro  
**Shade alabaster**

Estructura hierro pintado negro texturizado  
**Structure black textured epoxy painted iron**

LED integrado  
**Integrated LED**

---

No regulable **Not dimmable**  
2800/018

---

Regulable. Driver enchufable  
**Dimmable. Plug in driver**  
2800/018RG

---

LED Seoul 4.5W 270lm 2700K

---

CE   IP 20

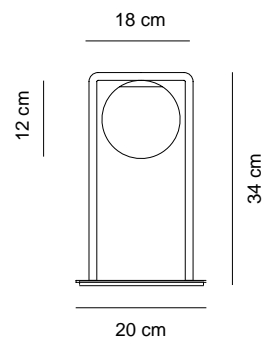



La otra mujer

Andrés Martín

El mundo es un teatro / Nuestra vida es un teatro

El mundo es un teatro / Nuestra vida es un teatro







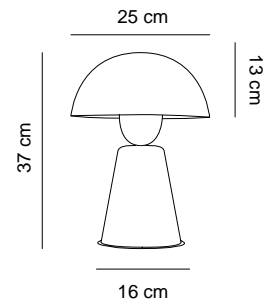

## Star

Design by Cristian Cubiña

Pantalla metacrilato opal  
**Shade opal methacrylate**

Estructura hierro pintado brillante  
**Structure gloss iron painted**

Regulador-interruptor incluido en el cable  
**Switch-dimmer in cable included**

Lámpara no incluida  
**Lamp not included**

2085/011 blanco brillante **glossy white**

2085/018 negro brillante **glossy black**

 E27 LED

CE  







## Paros Alabaster

Design by Josep Novell & Ernest Perera

Pantalla alabastro  
**Shade alabaster**

Estructura hierro pintado blanco texturizado  
**Structure textured white painted iron**

Sin regulador **without dimmer**

Lámpara no incluida  
**Lamp not included**

2270/011

 E14 / LED

CE  

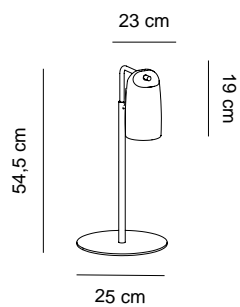





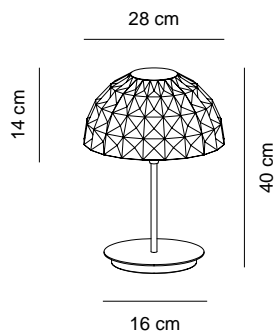

## Deco

Design by Cristian Cubiñá

Pantalla cristal prensado de Bohemia en acabado transparente  
**Shade Pressed Bohemia crystal in transparent finish**

Estructura hierro cromado  
**Structure chromed iron**

Sin regulador **Without dimmer**

Lámpara no incluida  
**Lamp not included**

2550/011 cromo **chrome**

2530/011 dorado brillo **polished gold**

 E14 LED

CE  







## Candle

Design by Cristian Cubiñá

Cristal soplado triplex opal  
**Opal triplex blown glass**

Regulador touch dimmer *with Touch dimmer*

LED integrado  
**Integrated LED**

2250/011 blanco mate ***matt white***

2250/016 níquel satinado ***satin nickel***

2250/017 cromo ***chrome***

LED 6W 3000K

CE  

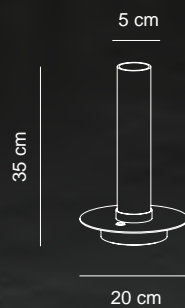



## Hotel

Design by Cristian Cubiñá

---

Estructura hierro acabado níquel satinado  
**Structure satin nickel iron**

Pantalla algodón negro  
**Shade black cotton**

Sin regulador **Without dimmer**

Lámpara no incluida  
**Lamp not included**

---

2540/018

 E27 LED

---

CE   IP 20

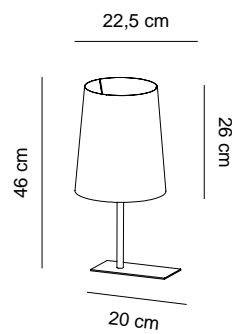





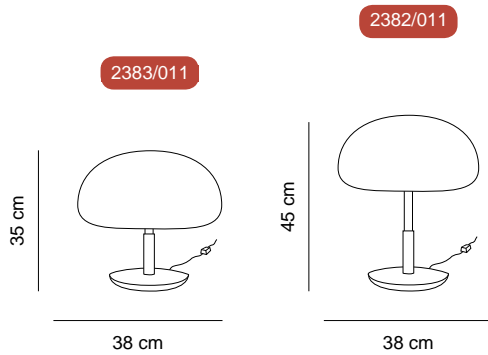

## Aspen

Design by Javier Taberner & Nacho Poveda

Pantalla cerámica esmaltada brillante  
**Shade shiny enamelled ceramic**

Estructura madera de roble / hierro pintado epoxi  
 /cable textil

**Structure oak wood / epoxy painted iron /  
 textile cable**

Sin regulador **Without dimmer**

Lámpara no incluida  
**Lamp not included**

2382/011

2383/011

 3xE14 LED

CE  

# Lámparas de pie Floor Lamps

Big Brother / Blow / Deco / Fuji / Hotel / Led Pole / Paros Alabaster / Star /  
Tribeca / Totem I / Totem II / Work







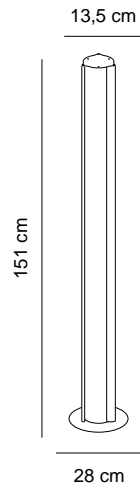

## Totem II

Design by Cristian Cubiña

Pantalla cristal de borosilicato estriado transparente  
**Shade transparent fluted borosilicate glass**

Estructura hierro pintado epoxi texturizado o baño electrolítico  
**Structure textured painted or electroplated iron**

Regulador con interruptor incluido en el cable  
**Switch - dimmer in cable included**

LED integrado  
**Integrated LED**

3333/012 bronce satinado **satin bronze**

3333/018 negro texturizado **textured black**

LED 230V 16W 1520lm 2700K >90CRI

CE  IP 20







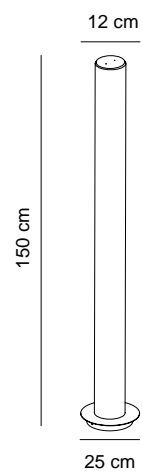
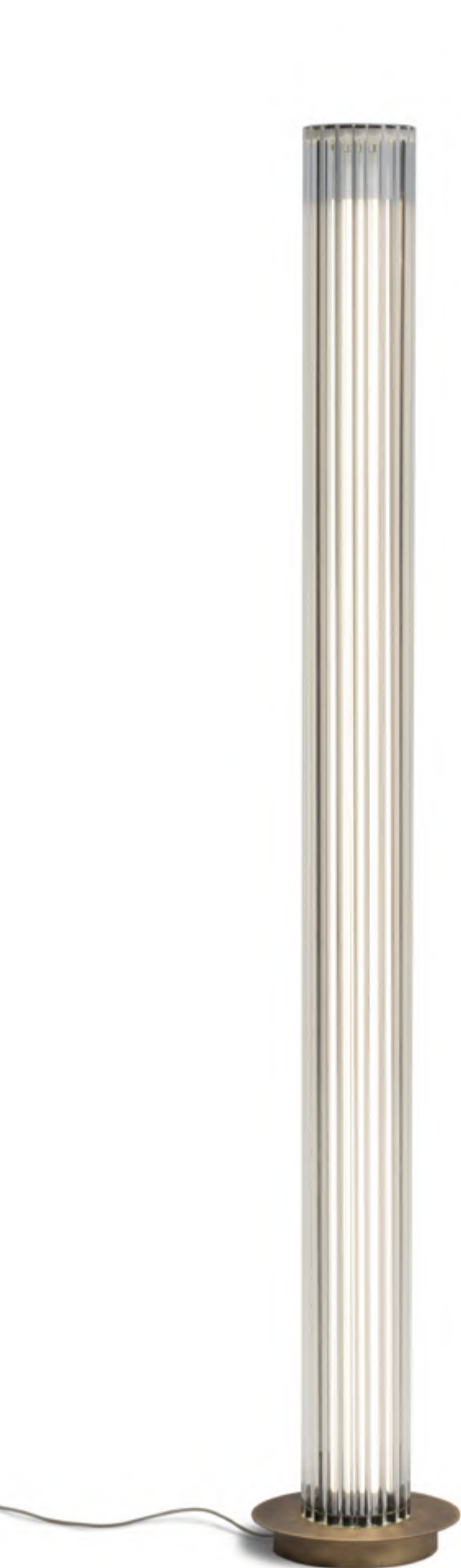

## Totem I

Design by Cristian Cubiña

Pantalla cristal de borosilicato estriado transparente  
Shade Transparent fluted borosilicate glass

Estructura: Hierro pintado epoxi texturizado o  
baño electrolítico **Structure Textured painted or  
electroplated iron**

No regulable. Versión regulable: contactar  
**Not dimmable. Dimmable version: please contact us**

Lámpara no incluida  
**Lamp not included**

3000/012 bronce satinado **satin bronze**

3000/018 negro texturizado **textured black**

2XG13 LED T8 150cm

CE  









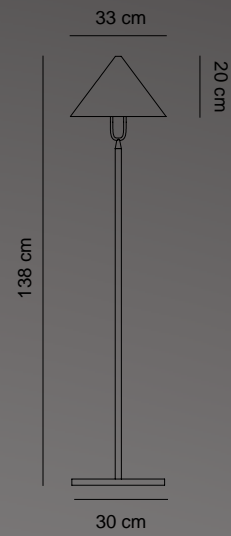
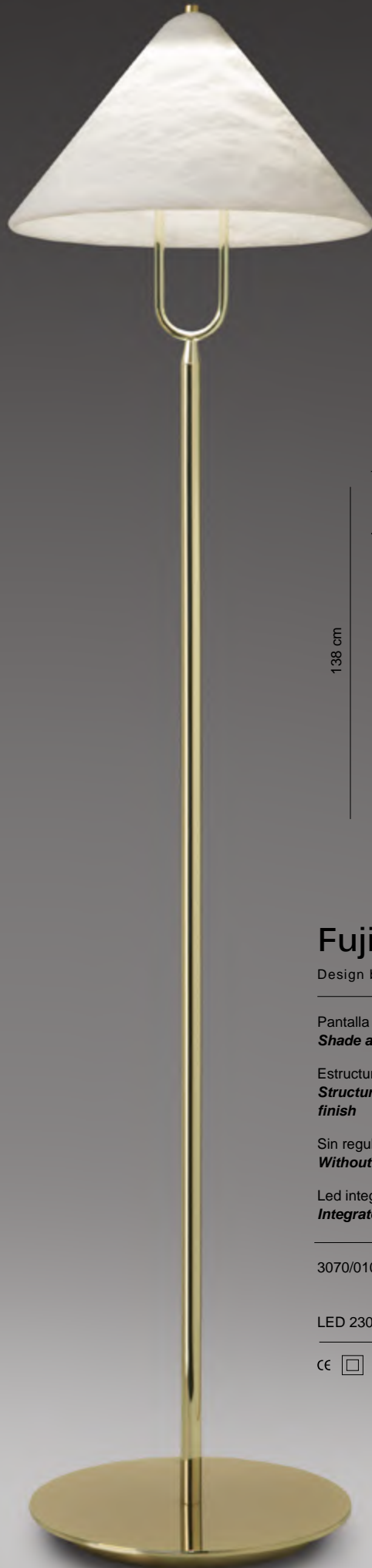

## Fuji

Design by Jordi LLopis

Pantalla alabastro  
**Shade alabaster**

Estructura hierro baño electrolítico latón pulido brillo  
**Structure iron with electrolytic bath in polished brass finish**

Sin regulador. Versión regulable: consultar  
**Without dimmer. Dimmable version: please contact us**

Led integrado  
**Integrated Led**

3070/010

LED 230V 4,83W 335lm 2700K

CE  





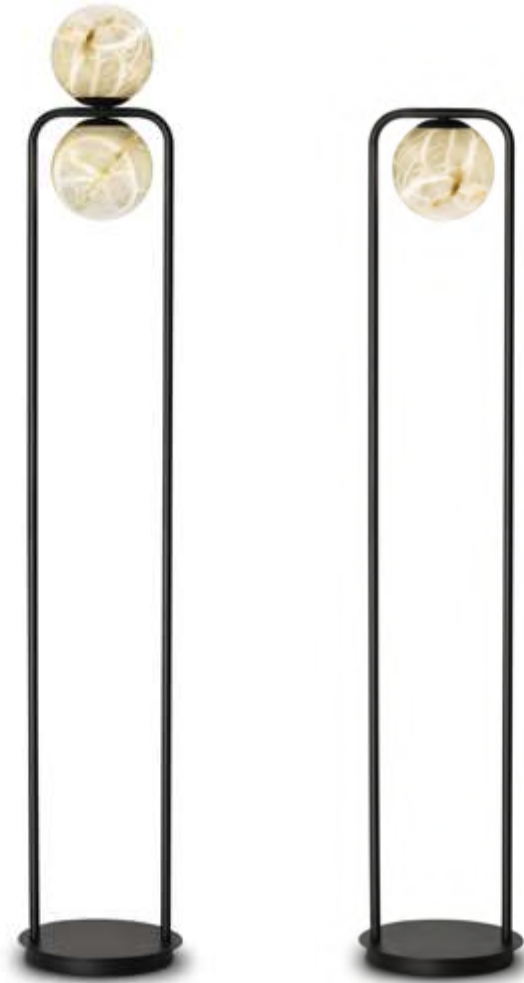

## Tribeca

Design by Jordi LLopis

Pantalla alabastro  
**Shade alabaster**

Estructura hierro pintado negro texturizado  
**Structure black textured epoxy painted iron**

LED integrado  
**Integrated LED**

No regulable **Not dimmable**

3800/018 108cm

3800/028 120cm

3810/028 180cm

Regulable. Driver enchufable

**Dimmable. Plug in driver**

3800/018RG 108cm

3800/028RG 120cm

3810/028RG 180cm

LED Seoul 4.5W 270lm 2700K

CE  IP 20

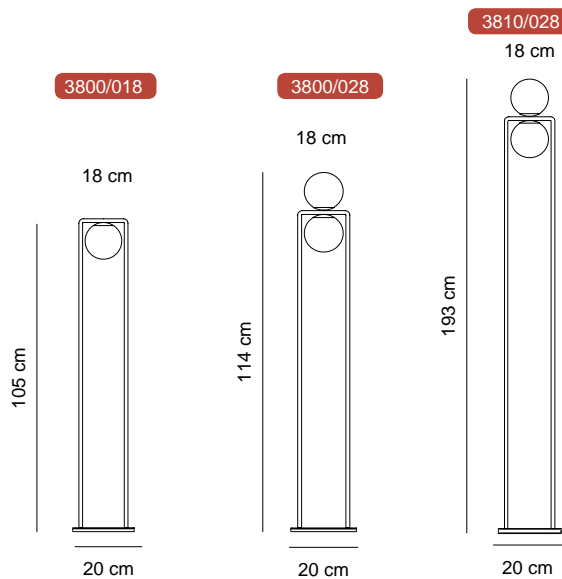







## Star

Design by Cristian Cubiña

---

Pantalla metacrilato opal  
**Shade opal methacrylate**

Estructura hierro pintado brillante  
**Structure gloss iron painted**

Regulador-interruptor incluido en el cable  
**Switch-dimmer in cable included**

Lámpara no incluida  
**Lamp not included**

---

3085/011 blanco brillante **glossy white**

3085/018 negro brillante **glossy black**

 E27 LED

CE  

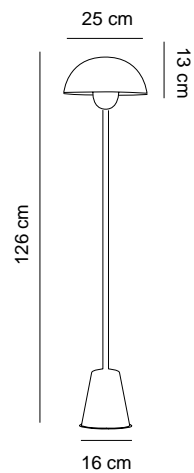







## Paros Alabaster

Design by Josep Novell & Ernest Perera

Pantalla alabastro

**Shade alabaster**

Estructura hierro pintado blanco texturizado

**Structure textured white painted iron**

Sin regulador **without dimmer**

Lámpara no incluida, reemplazable

**Lamp not included, replaceable**

3270/011

 E14 LED

CE  

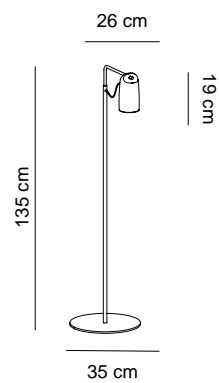

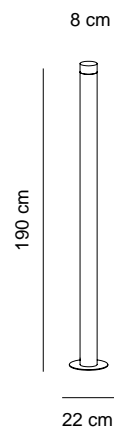
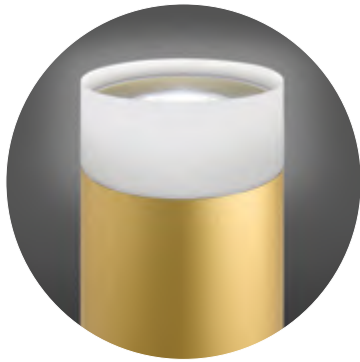

## Led Pole

Design by Cristian Cubiñá

---

Pantalla metacrilato arenado  
**Shade sand blasted methacrylate**

Estructura extrusión aluminio  
**Structure extruded aluminum**

**Regulador-interruptor incluido en el cable.**  
**Switch-dimmer in cable included**

LED integrado  
**Integrated LED**

---

3160/011 blanco texturizado **textured white**

3160/018 negro texturizado **textured black**

3160/016 anodizado plata mate **anodized matt silver**

3160/010 anodizado dorado mate **anodized matt gold**

LED Talex Stark module 20W 3500lm 3000K













## Big Brother

Design by Oriol Llahona

Pantalla textil de polipropileno blanco y asa en cuero grabado  
**Shade white polypropylene textile and engraved leather handle**

Estructura hierro pintado blanco mate  
**Structure white painted iron**

Regulador-interruptor incluido en el cable  
**Switch-dimmer in cable included**

Lámpara no incluida  
**Lamp not included**

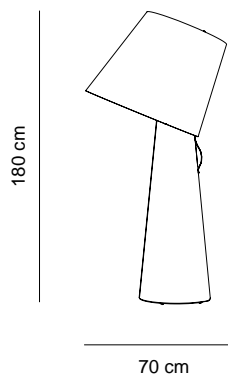

3950/011

 3 X E27 LED

CE  

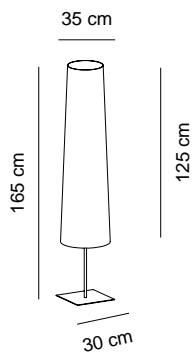

## Hotel

Design by Cristian Cubiñá

Pantalla algodón negro

**Shade black cotton**

Estructura hierro acabado níquel satinado

**Structure satin nickel iron**

Sin regulador **without dimmer**

Lámpara no incluida

**Lamp not included**

3540/018

 E27 LED

CE  





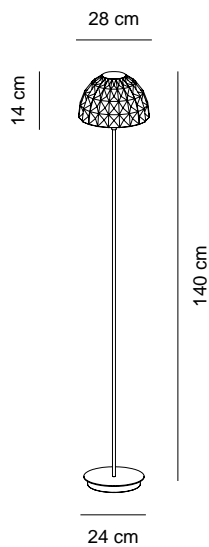

## Deco

Design by Cristian Cubiñá

Pantalla cristal prensado de Bohemia en acabado transparente  
**Shade Pressed Bohemia crystal transparent glass**

Estructura hierro cromado  
**Structure chromed iron**

Sin regulador **Without dimmer**

Lámpara no incluida  
**Lamp not included**

3550/011 cromo **chrome**

3530/011 dorado brillo **polished gold**

 E14 LED

CE  



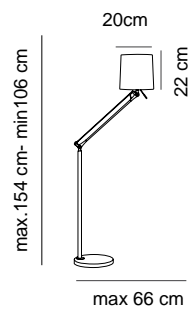

## Work

---

Pantalla textil almadén plata  
**Shade silver almadén textile**

Estructura aluminio anodizado plata mate  
**Structure aluminium matt silver anodized**

Sin regulador **Without dimmer**

Lámpara no incluida  
**Lamp not included**

---

4245/019

 E27 LED

---

CE  



# Suspensiones Hanging Lamps

Bath A Led / Biscuit / Blow / Deco / Drop Led / Fuji / Led Box / Led Oval  
/ Lens Led / Moon / Paros Alabaster / Soft / Stone Led / SuperMoon /  
TheChandelier / TheLight / ThePalm / Totem II / Tribeca









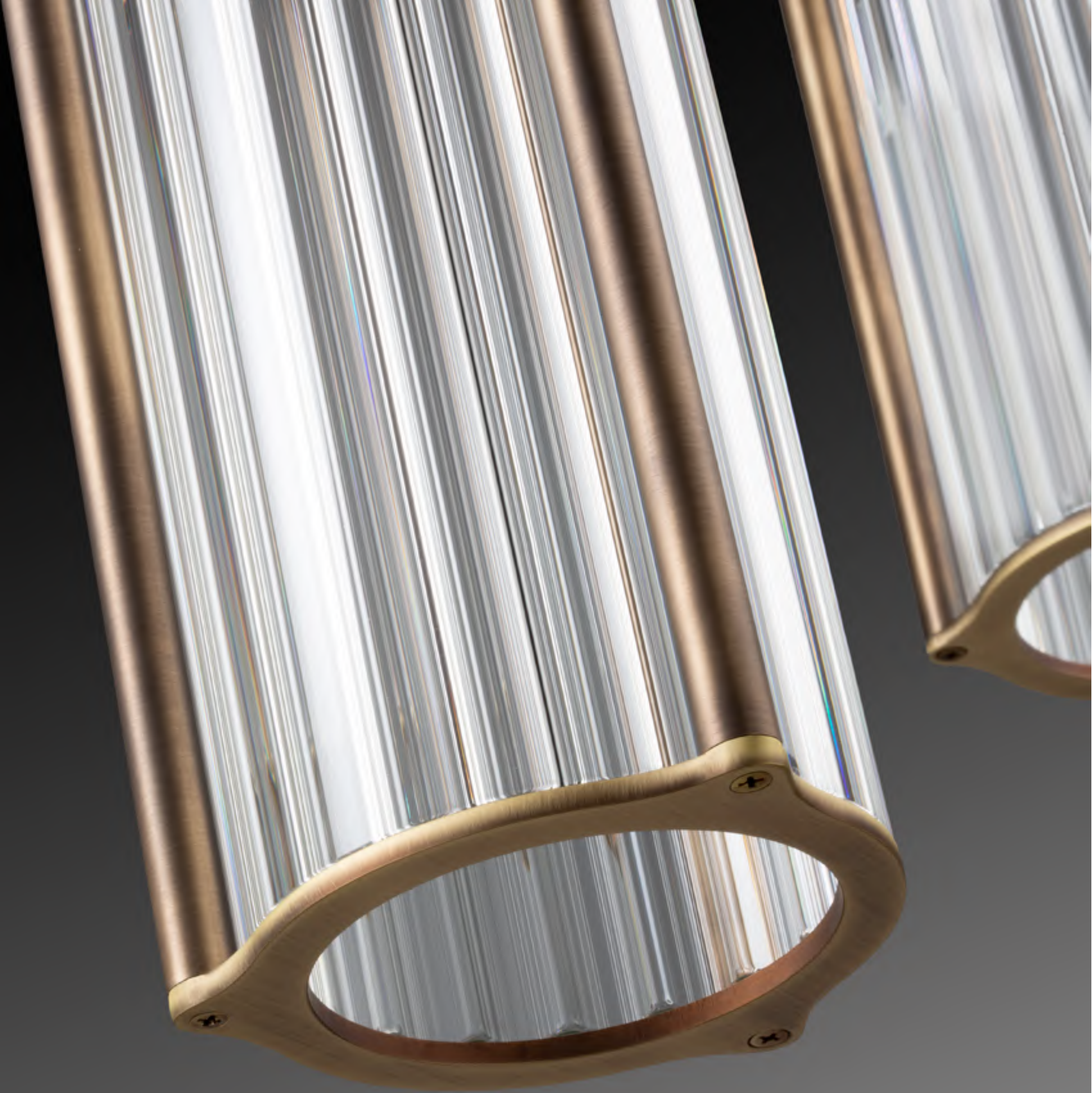



## Totem II

Design by Cristian Cubiña

Pantalla cristal de borosilicato estriado transparente  
**Shade transparent fluted borosilicate glass,**

Estructura hierro pintado texturizado o baño electrolítico  
**Structure textured painted or electroplated iron**

Regulable mediante Triac  
**Dimmable by Triac**

LED integrado  
**Integrated LED**

5335/012 bronce satinado **satin bronze 25cm**

5335//018 negro texturizado **textured black 25cm**

5336/012 bronce satinado **satin bronze 50cm**

5336/018 negro texturizado **textured black 50cm**

LED 230V 16W 1520lm 2700K >90CRI

5333/012 bronce satinado **satin bronze 25cm**

5333//018 negro texturizado **textured black 25cm**

5334/012 bronce satinado **satin bronze 50cm**

5334/018 negro texturizado **textured black 50cm**

LED 230V 10W 920lm 2700K >90CRI

CE  

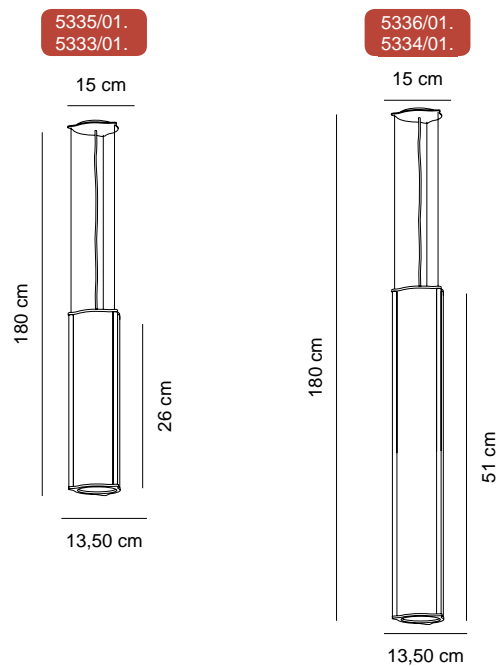

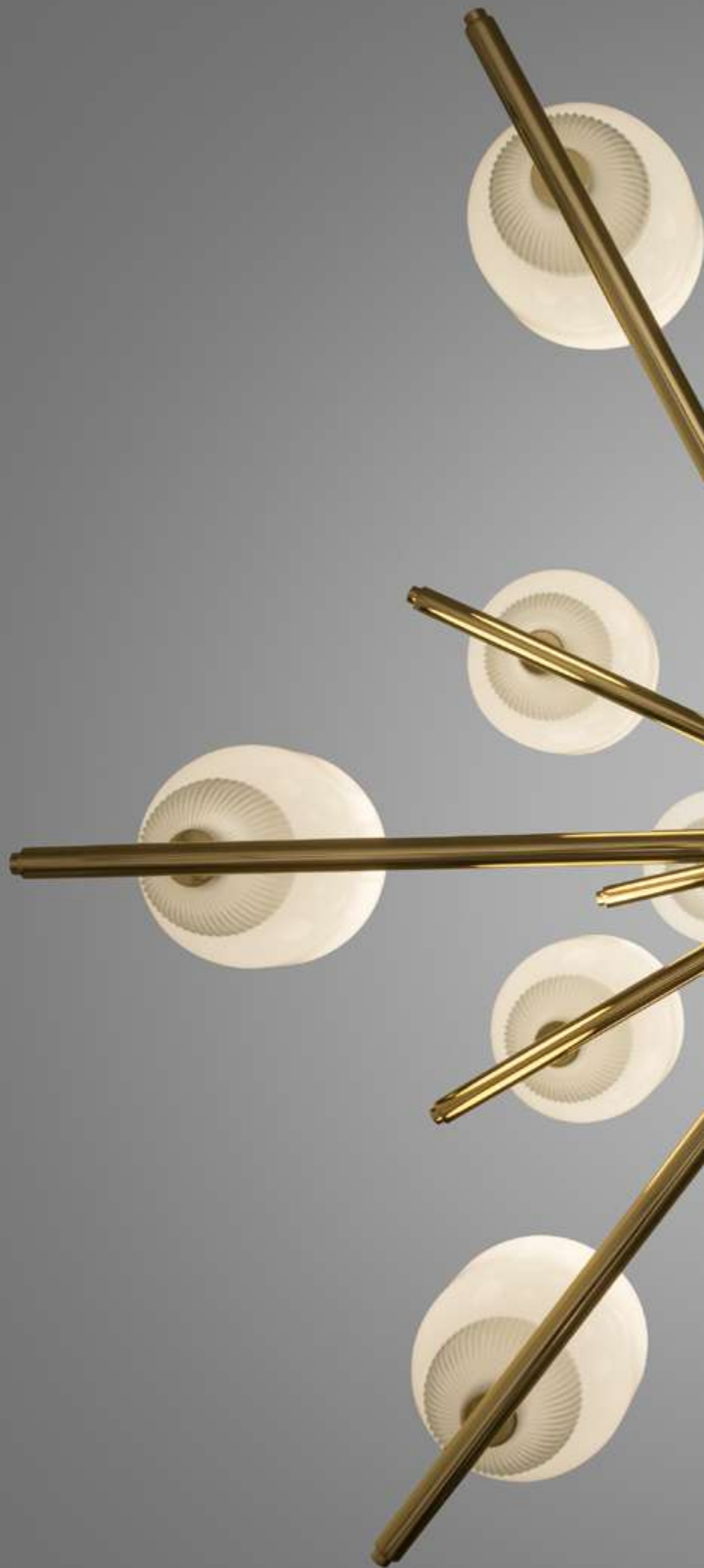























# TheChandelier

Design by Alfonso de la Fuente (Pichiglas Studio)

Pantalla cristal opal  
**Shade opal glass**

Estructura hierro  
**Structure iron**

Lámparas no incluidas **Lamps not included**

5170/031 colgante 3 brazos blanco texturizado **pendant 3 arms textured white**

5170/038 colgante 3 brazos negro texturizado **pendant 3 arms textured black**

5170/030 colgante 3 brazos latón pulido brillo **pendant 3 arms polished brass**

5170/091 colgante 9 brazos blanco texturizado **pendant 9 arms textured white**

5170/098 colgante 9 brazos negro texturizado **pendant 9 arms textured black**

5170/090 colgante 9 brazos latón pulido brillo **pendant 9 arms polished brass**

5170/151 colgante 15 brazos blanco texturizado **pendant 15 arms textured white**

5170/158 colgante 15 brazos negro texturizado **pendant 15 arms textured black**

5170/150 colgante 15 brazos latón pulido brillo **pendant 15 arms polished brass**

 E27 LED

CE   IP 20

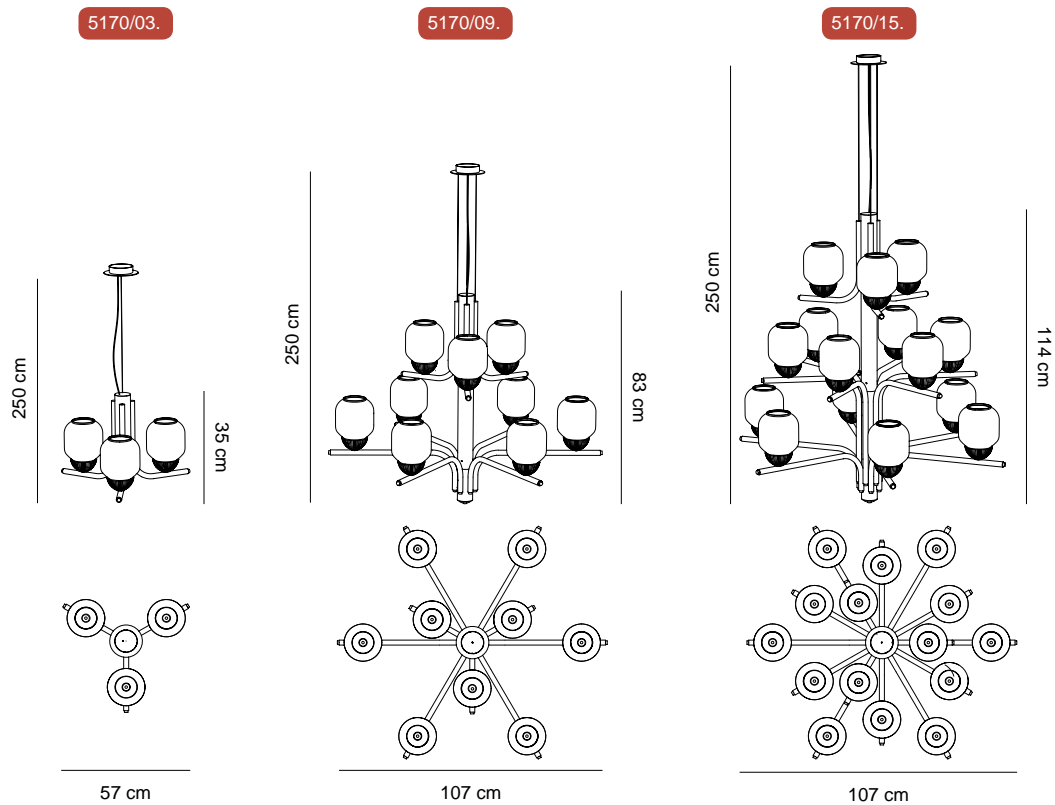











## Fuji

Design by Jordi Llopis

Pantalla alabastro  
**Shade alabster**

Estructura hierro baño electrolítico latón pulido brillo  
**Structure iron with electrolytic bath in polished brass finish**

Lámpara incluida y no reemplazable  
**Lamp included and not replaceable**

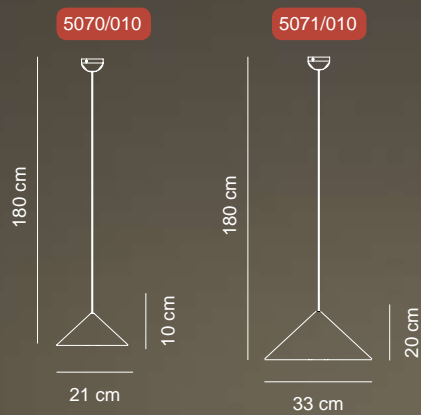

5070/010 no regulable **not dimmable**

LED Seoul 4,6W 2700K 260lm

5071/010 no regulable **Not dimmable**

LED 230V 4,85W 2700K 335lm

5070/010RG regulable **dimmable**

LED Seoul 4,6W 2700K 260lm

5071/010RG regulable **dimmable**

LED 230V 4,85W 335lm 2700K

CE  IP 20

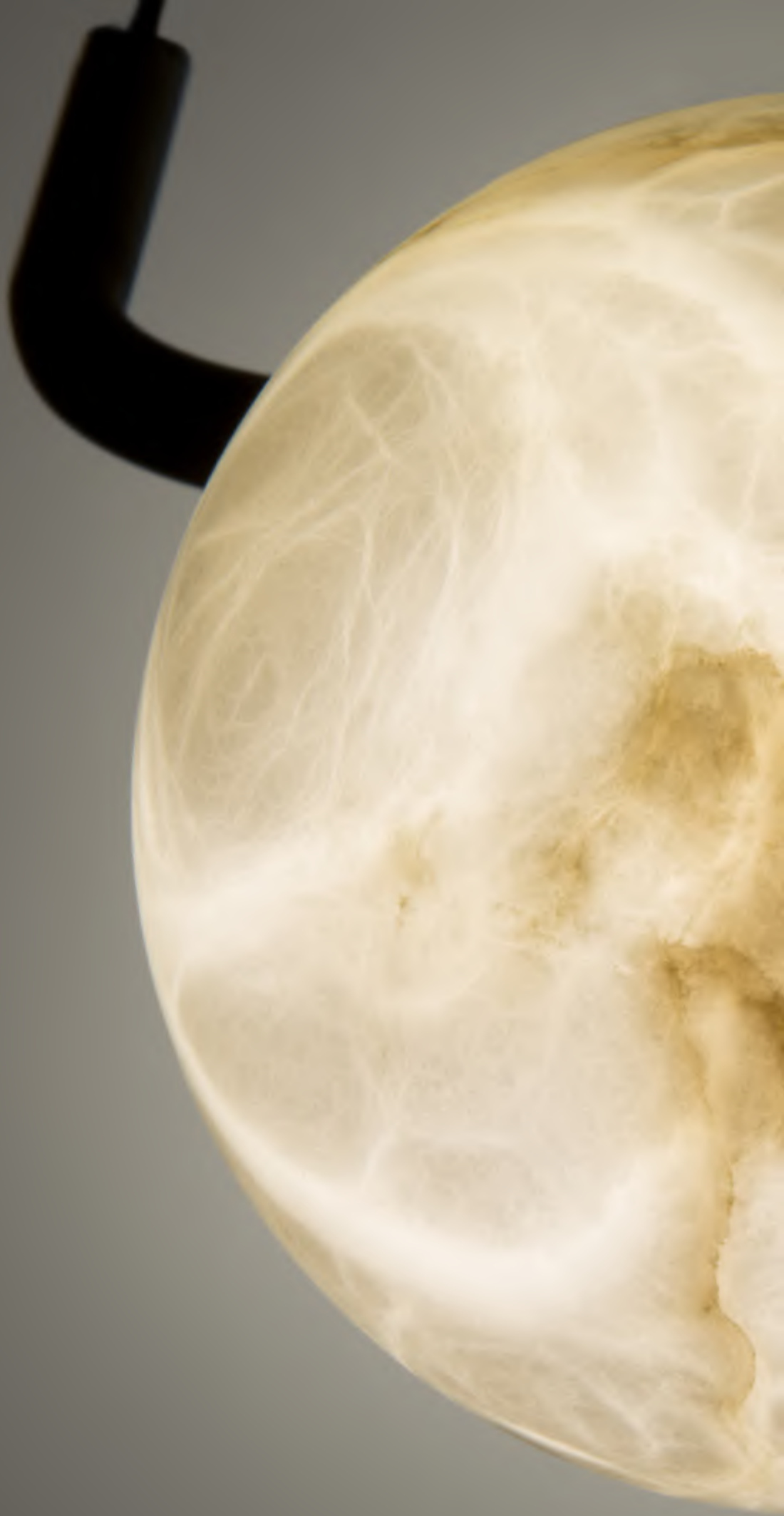







## Tribeca

Design by Jordi LLopis

Pantalla alabastro  
**Shade alabaster**

Estructura hierro pintado negro texturizado  
**Structure black textured epoxy painted iron**

Led integrado  
**Integrated Led**

No regulable **Not dimmable**

5800/018

5800/028

Regulable **Dimmable**

5800/018RG

5800/028RG

LED Seoul 4.5W 270lm 2700K

CE   IP 20

5800/018

5800/028

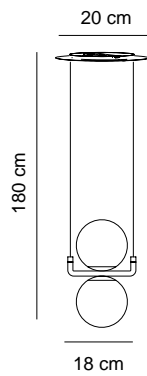
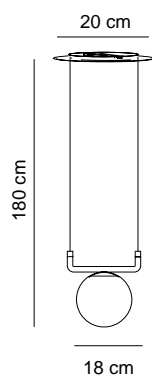





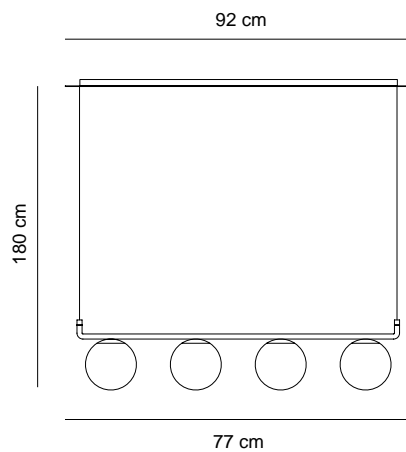
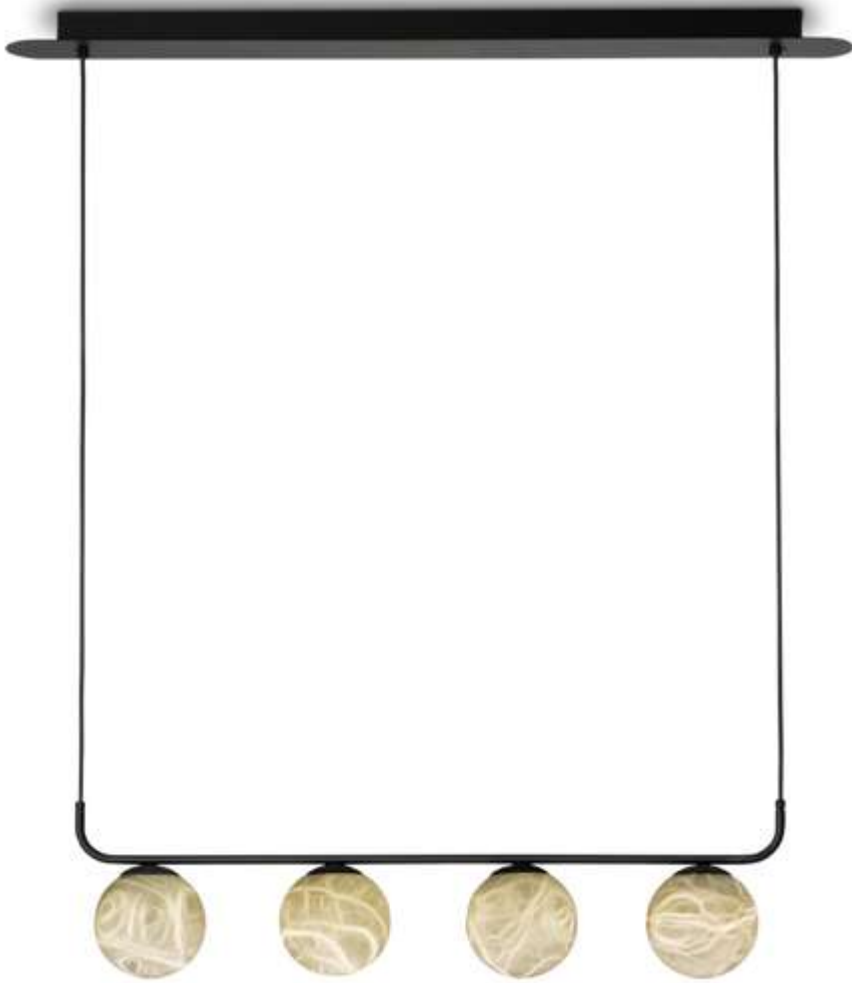

## Tribeca

Design by Jordi LLopis

Pantalla alabastro  
**Shade alabaster**

Estructura hierro pintado negro texturizado  
**Structure textured black painted iron**

Led integrado  
**Integrated Led**

No regulable **Not dimmable**

5800/048

Regulable **Dimmable**

5800/048RG

4 x LED Seoul 4,5W 270lm 2700K

CE  IP 20



## Paros Alabaster

Design by Josep Novell & Ernest Perera

Pantalla alabastro  
**Shade alabaster**

Estructura hierro pintado blanco texturizado  
**Structure textured white painted iron**

Lámpara no incluida  
**Lamp not included**

5270/011

 E14 LED

CE  

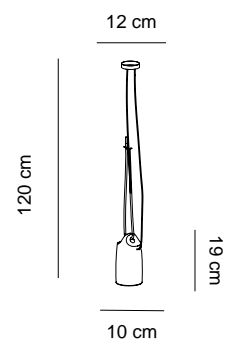











## ThePalm

Design by Cristian Cubiñá

---

Pantalla metacrilato arenado  
**Shade sandblasted methacrylate**

Estructura hierro  
**Structure iron**

No regulable. Versión regulable: consltar  
**Not dimmable. Dimmable version: please contact us**

Led integrado. Integrated Led

---

5190/121 22,9W 1889lm 2700K blanco texturizado **textured white**

5190/128 22,9W 1889lm 2700K negro texturizado **textured black**

5190/126 22,9W 1889lm 2700K níquel satinado **satín nickel**

5190/120 22,9W 1889lm 2700K dorado satinado **satín gold**

5190/181 34,34W 2834lm 2700K blanco texturizado **textured white**

5190/188 34,34W 2834lm 2700K negro texturizado **textured black**

5190/186 34,34W 2834lm 2700K níquel satinado **satín nickel**

5190/180 34,34W 2834lm 2700K dorado satinado **satín gold**

5190/301 57,24W 4723lm 2700K blanco texturizado **textured white**

5190/308 57,24W 4723lm 2700K negro texturizado **textured black**

5190/306 57,24W 4723lm 2700K níquel satinado **satín nickel**

5190/300 57,24W 4723lm 2700K dorado satinado **satín gold**

---

LED Seoul

CE IP 20

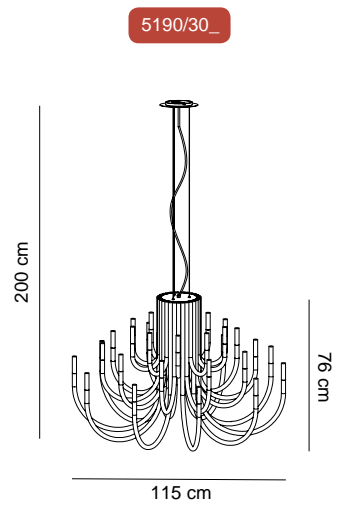
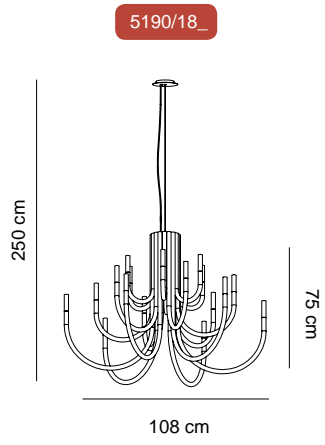
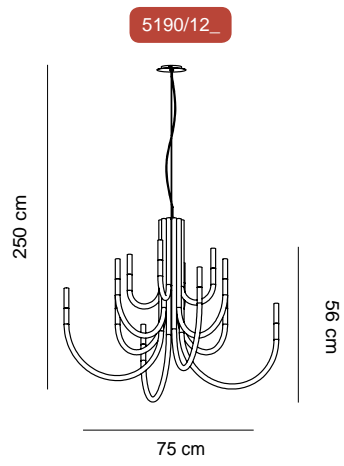



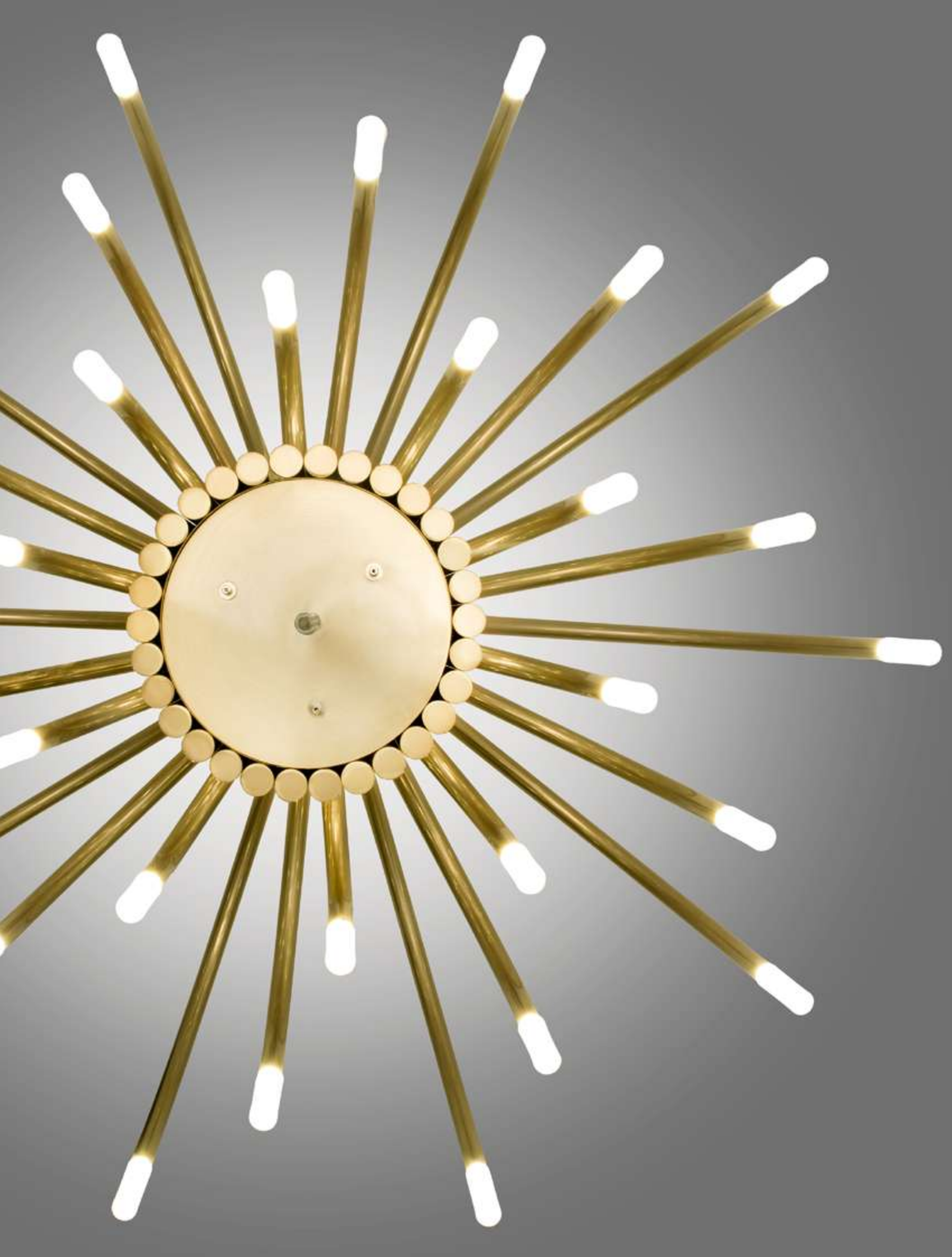







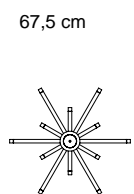
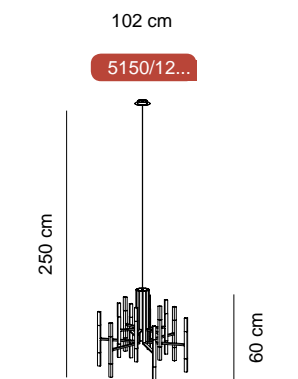
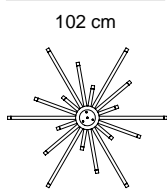
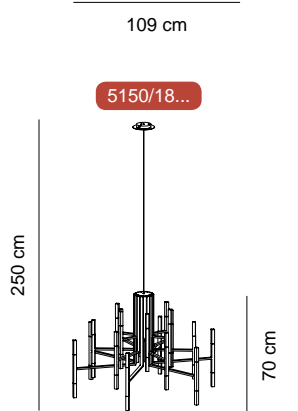
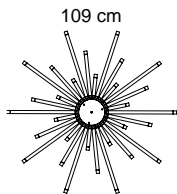
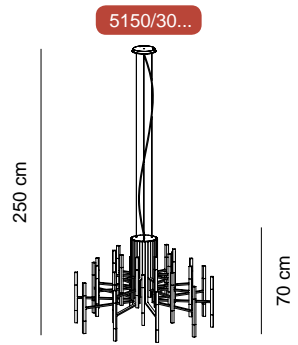

67,5 cm





# TheLight

Design by Cristian Cubiñá

---

Estructura hierro  
**Structure iron**

Pantalla metacrilato arenado  
**Shade sandblasted methacrylate**

No regulable. Versión regulable: consltar  
**Not dimmable. Dimmable version: please contact us**

Led integrado. **Integrated Led.**

---

5150/121 25,15W 2498lm 2700K blanco mate ***matt white***  
5150/128 25,15W 2498lm 2700K negro mate ***matt black***  
5150/126 25,15W 2498lm 2700K níquel satinado ***satin nickel***  
5150/120 25,15W 2498lm 2700K dorado satinado ***satin gold***

5150/181 37,76W 3748lm 2700K blanco mate ***matt white***  
5150/188 37,76W 3748lm 2700K negro mate ***matt black***  
5150/186 37,76W 3748lm 2700K níquel satinado ***satin nickel***  
5150/180 37,76W 3748lm 2700K dorado satinado ***satin gold***

5150/301 62,88W 6245lm 2700K blanco mate ***matt white***  
5150/301 62,88W 6245lm 2700K negro mate ***matt black***  
5150/306 62,88W 6245lm 2700K níquel satinado ***satin nickel***  
5150/300 62,88W 6245lm 2700K dorado satinado ***satin gold***

---

LED Seoul

CE IP 20



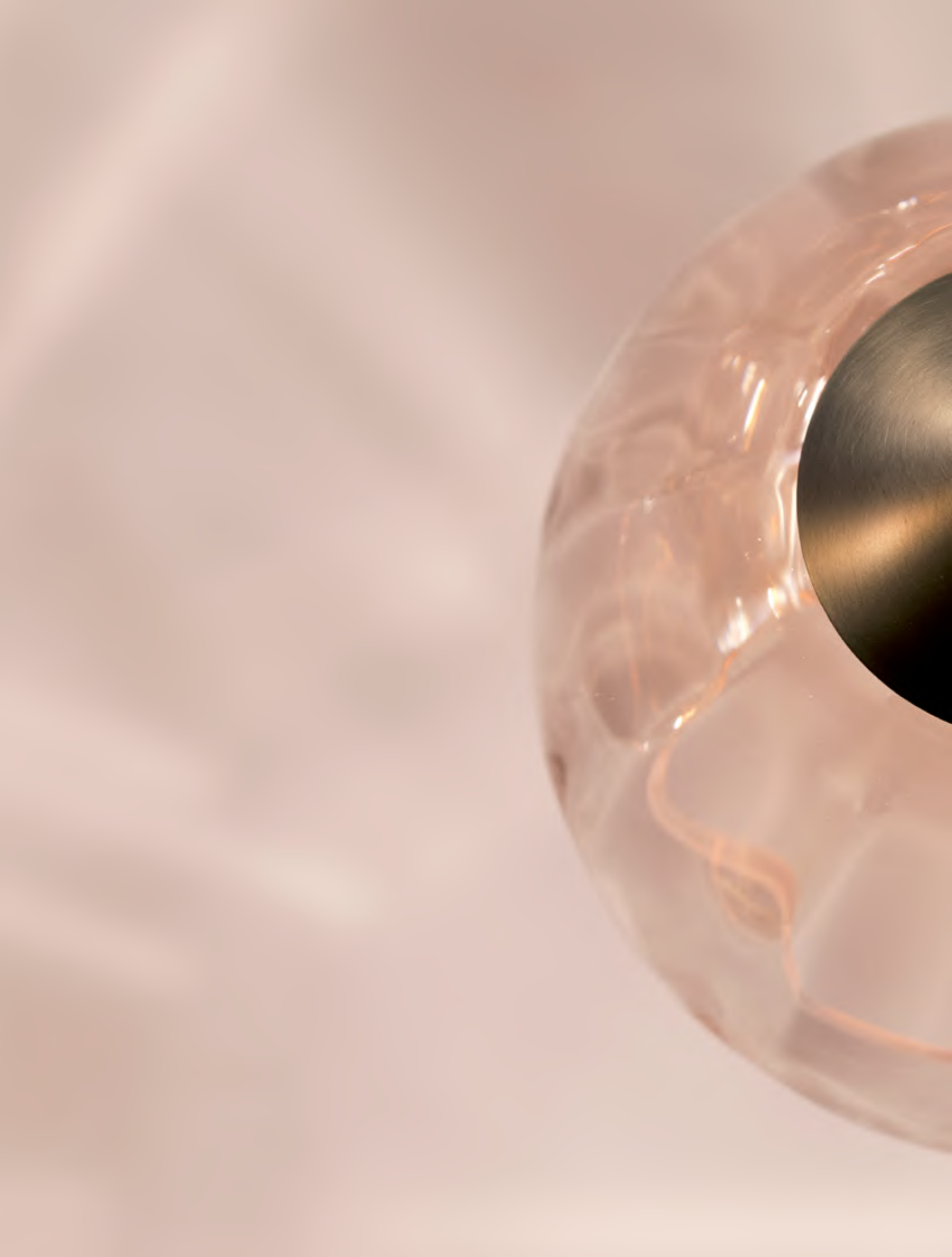





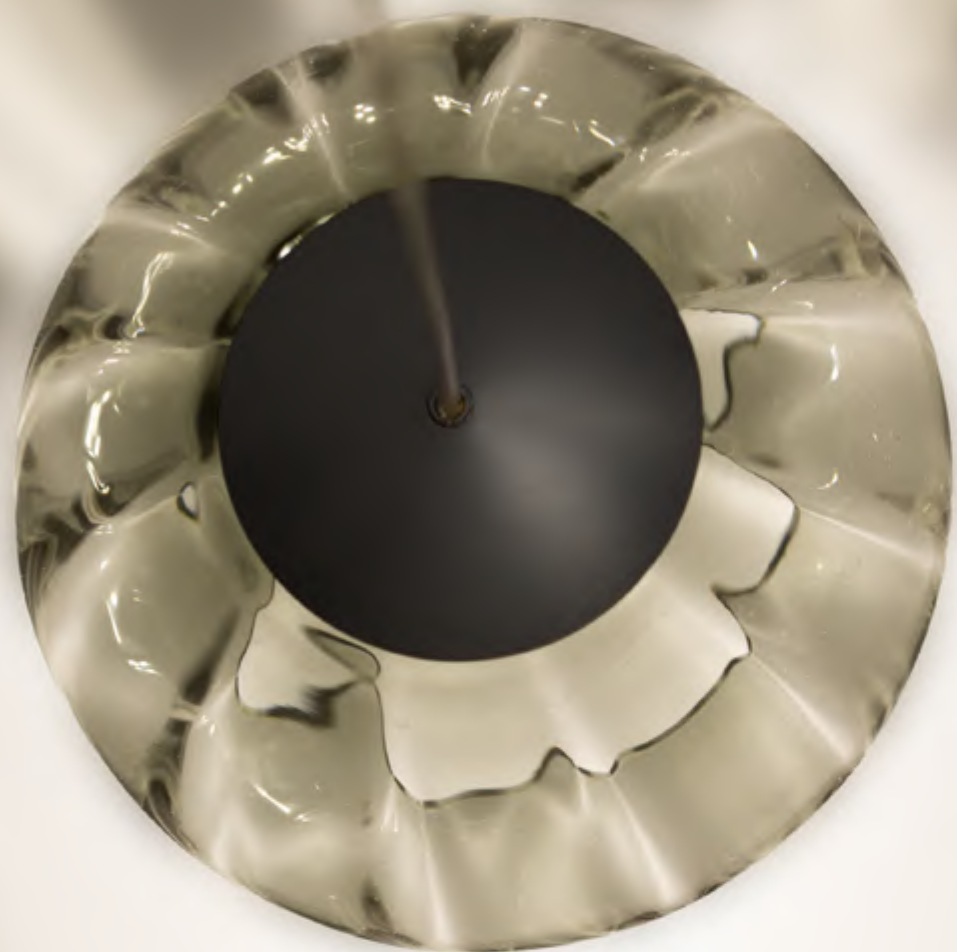

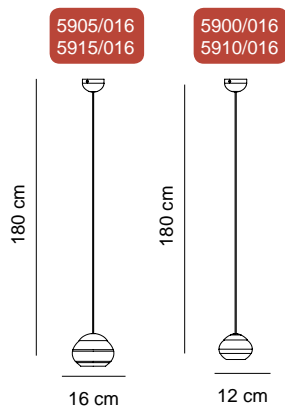
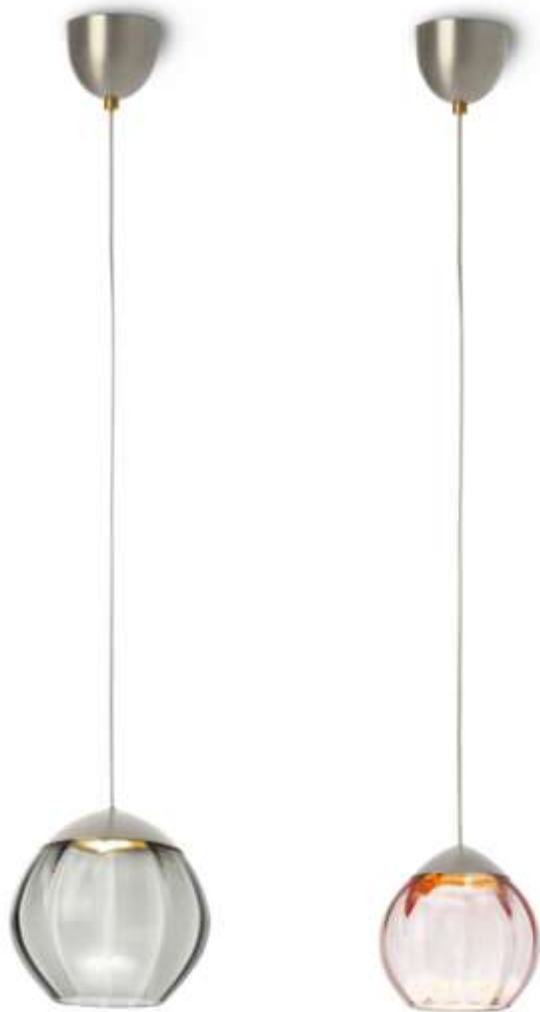

## Soft

Design by Cristian Cubiñá

Pantalla cristal soplado rosado o negro  
**Shade blown glass pink or black**

Estructura hierro níquel satinado.  
**Structure iron satin nickel**

No regulable  
**Not dimmable**

Led integrado  
**Integrated Led**

5900/016 cristal pequeño rosado **small pink glass**

5905/016 cristal grande rosado **big pink glass**

5910/016 cristal pequeño negro **small black glass**

5915/016 cristal grande negro **big black glass**

LED Seoul 3W 372lm 2700K

CE  IP 20

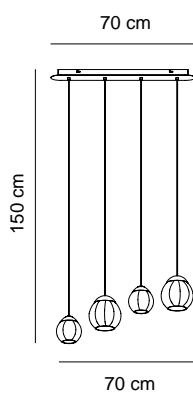

## Soft

Design by Cristian Cubiñá

Pantalla cristal soplado rosado o negro  
**Shade blown glass pink or black**

Estructura hierro níquel satinado.  
**Structure iron satin nickel**

No regulable  
**Not dimmable**

Led integrado  
**Integrated Led**

5900/046 cristal rosado **pink glass**

5910/046 cristal negro **black glass**

LED Seoul 3W 372lm 2700K

CE IP 20







## Soft

Design by Cristian Cubiñá

Pantalla cristal soplado rosado o negro  
**Shade blown glass pink or black**

Estructura hierro níquel satinado.  
**Structure iron satin nickel**

No regulable  
**Not dimmable**

Led integrado  
**Integrated Led**

5900/056 cristal rosado **pink glass**

5910/056 cristal negro **black glass**

LED Seoul 3W 372lm 2700K

CE IP 20

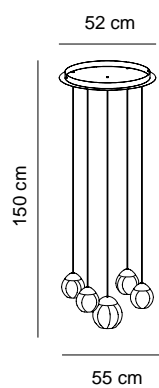







## Moon

Design by Josep Novell & Ernest Perera

---

Pantalla Polietileno rotomoldeado opal  
**Shade white textured rotomolded polyethylene**

Estructura hierro pintado blanco texturizado  
**Structure iron textured white painted**

No regulable  
**Not dimmable**

Led integrado  
**Integrated Led**

---

5850/011

LED Epistar 40W 3250lm 3000K

---

CE  IP 23

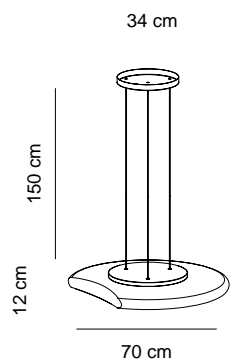





## SuperMoon

Design by Josep Novell & Ernest Perera

Pantalla Polietileno rotomoldeado opal  
**Shade white textured rotomolded polyethylene**

Estructura hierro pintado blanco texturizado  
**Structure iron textured white painted**

No regulable  
**Not dimmable**

Led integrado  
**Integrated Led**

5860/041

4 x LED Epistar 40W 3250lm 3000K

CE  IP 20

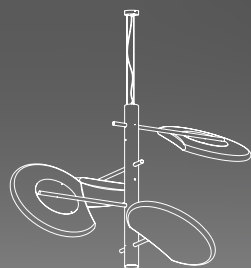

180 cm

200 cm



## Deco

Design by Cristian Cubiñá

Pantalla cristal prensado de Bohemia en acabado transparente  
**Shade Pressed Bohemia crystal transparent glass**

Estructura hierro  
**Structure iron**

Lámpara no incluida  
**Lamp not included**

5550/011 cromo **chome**

5530/011 dorado brillo **polished gold**

 G9 LED

CE  IP 20

13 cm

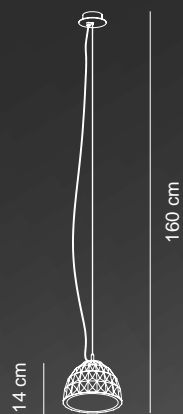

14 cm

160 cm

28 cm







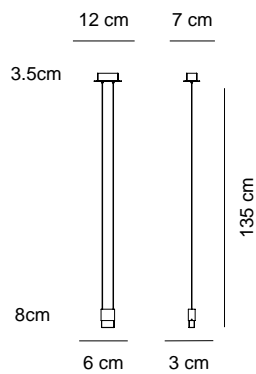

## Led Box

Design by Cristian Cubiñá

Pantalla fundición aluminio pulido  
**Shade polished die cast aluminium**

Cristal transparente arenado  
**Transparent sandblasted glass**

Estructura de acero inoxidable pulido espejo  
**Structure mirror polished stainless steel**

No regulable  
**Not dimmable**

Led integrado  
**Integrated Led**

5080/016

LED Citizen 3W 250lm 2700K

CE IP 20









# Led Oval

Design by Cristian Cubiñá

Pantalla fundición aluminio pulido  
**Shade polished die cast aluminium**

Estructura acero inoxidable pulido espejo  
**Structure mirror polished stainless steel**

No regulable  
**Not dimmable**

Led integrado  
**Integrated Led**

5180/017 colgante individual **single pendant**

5180/047 colgante lineal 4 luces **linear pendant 4 lights**

LED Citizen 3W 250lm 2700K

CE IP 20

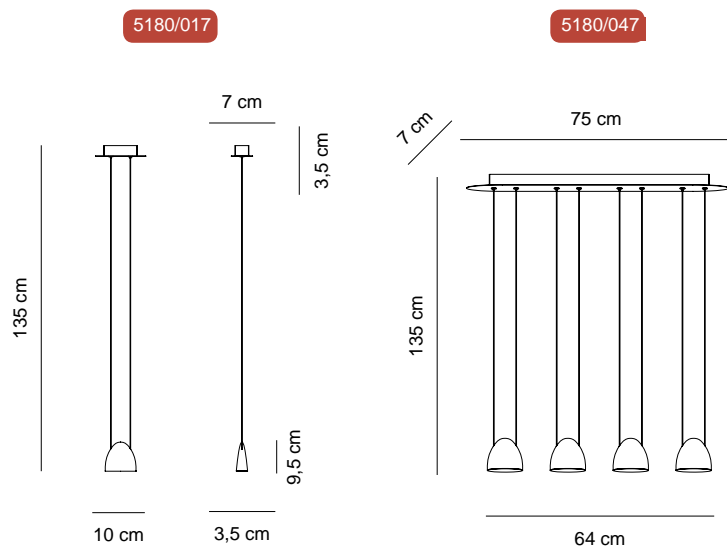
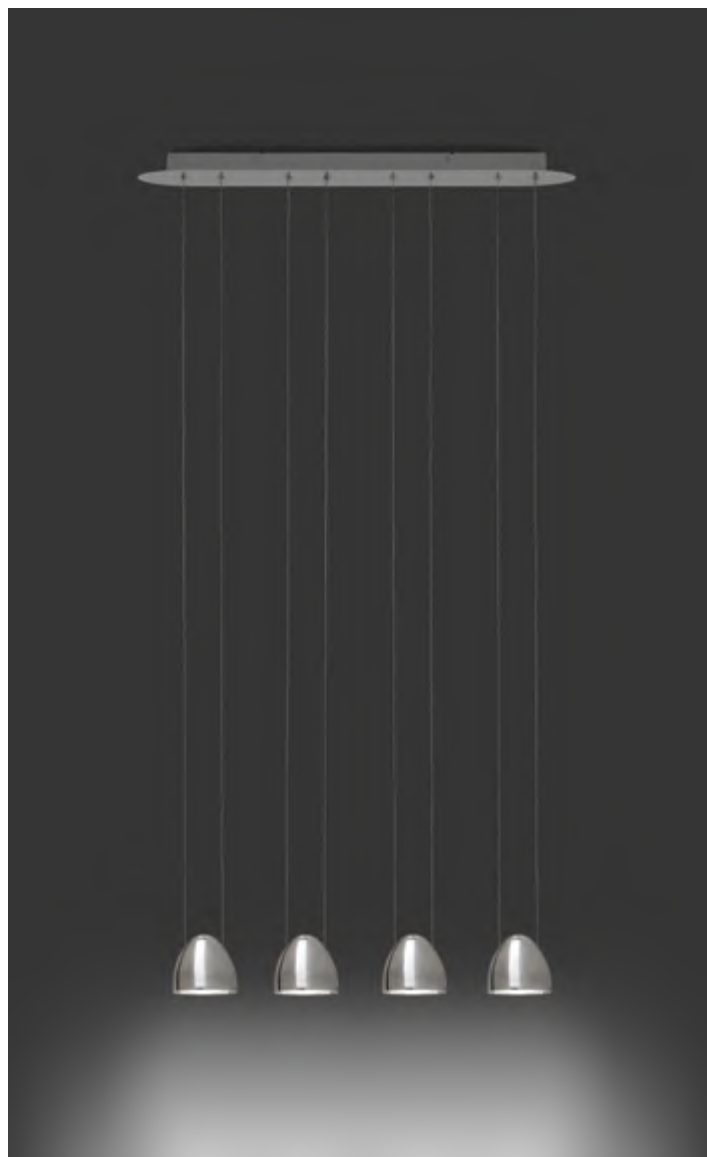

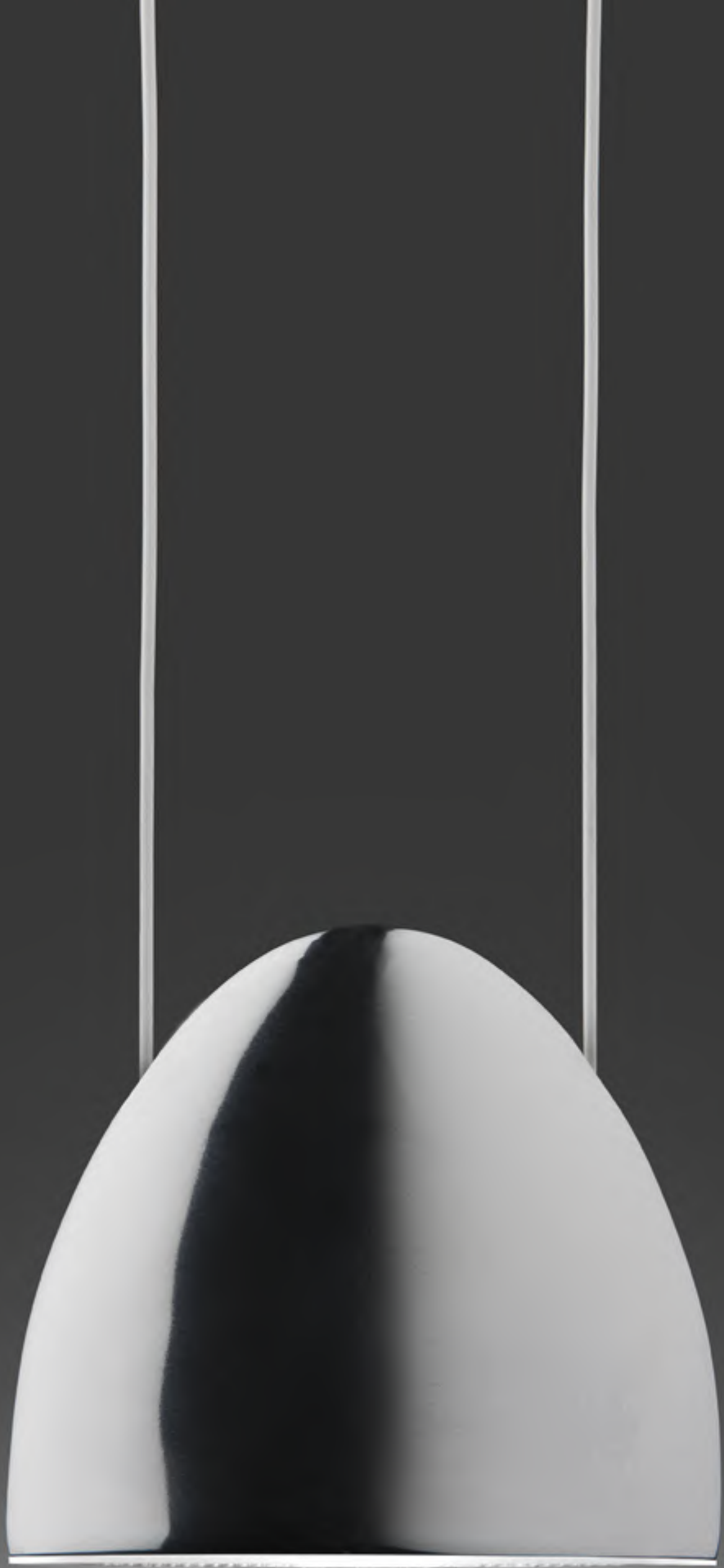





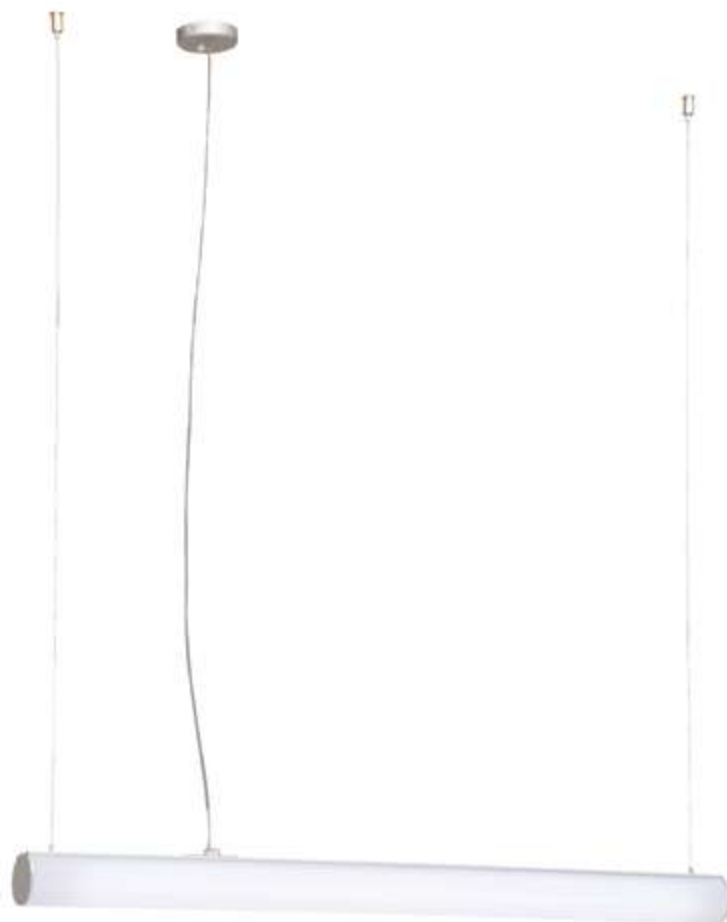

## Bath A Led

Design by Oriol Llahona

Pantalla policarbonato opal  
**Shade opal polycarbonate**

Estructura hierro pintado epoxi  
**Structure epoxy painted iron**

Regulable mediante Triac  
**Dimmable byTriac**

Led integrado  
**Lamp included**

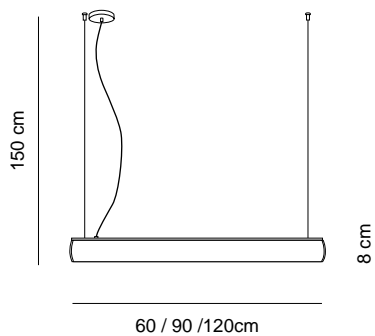

5420/061LED 60cm 14W 1350lm blanco mate **matt white**  
5420/091LED 90cm 22W 2160lm blanco mate **matt white**  
5420/121LED 120cm 30,8W 2970lm blanco mate **matt white**

5420/066LED 60cm 14W 1350lm plata **silver**  
5420/096LED 90cm 22W 2160lm plata **silver**  
5420/126LED 120cm 30,8W 2970lm plata **silver**

Led 3000K

CE IP 23













## Lens Led

Design by Cristian Cubiná

---

Pantalla metacrilato opal  
**Shade opal methacrylate**

Estructura hierro pintado epoxi blanco mate  
**Structure iron epoxi matt white painted**

No Regulable  
**Not dimmable**

Led integrado  
**Integrated Led**

---

5290/011

LED Epistar 40W 3250lm 3000K

---

CE IP 20

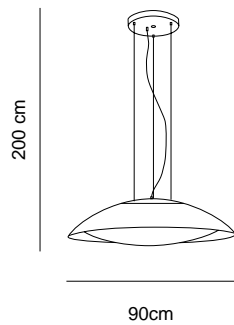

200 cm

90cm



## Stone Led

Design by Josep Puig & Josep Novell

---

Pantalla polietileno rotomoldeado  
**Shade rotomolded polyethylene**

Estructura hierro pintado epoxi blanco mate  
**Structure epoxy matt white painted iron**

No Regulable  
**Not dimmable**

Led integrado  
**Integrated Led**

---

5300/036

LED Epistar 40W 3250lm 3000K

---

CE IP 20

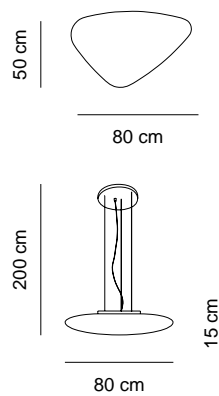





Al subir y bajar el aro de silicona conseguimos variar la forma de luminaria.



**By pulling up or down the silicon ring we can modify the external outfit of the luminaire.**

## Drop Led

Design by Cristian Cubiñá

Pantalla cristal borosilicato transparente  
**Shade borosilicate transparent glass**

Estructura hierro cromado  
**Structure chrome iron**

Cables pueden acortarse máx 60cm  
**Cables can be shortened max. 60cm**

Lámparas Led incluidas, reemplazables, no regulables  
**Led lamps included, replaceable, not dimmable**

Estructura normal largo max.170 - min.110cm  
**Normal structure length max.170 - min.110cm**

5110/196LED G4 19x1,1W 95lm 2700K CRI>80

5110/376LED G4 37x1,1W 95lm 2700K CRI>80

Estructura especial largo 70cm

**Special structure length 70cm**

5110/196S LED G4 19x1,1W 95lm 2700K CRI>80

5110/376S LED G4 37x1,1W 95lm 2700K CRI>80

Estructura especial largo max.350 - min.290cm

**Special structure length max.350 - min.290cm**

5110/196XL LED G4 19x1,1W 95lm 2700K CRI>80

5110/376XL LED G4 37x1,1W 95lm 2700K CRI>80

5110/196

16 cm

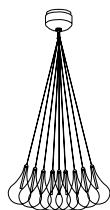

∅ 60 cm

5110/376

20 cm

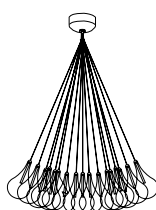

∅ 80 cm

CE IP 20







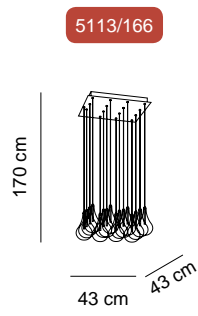
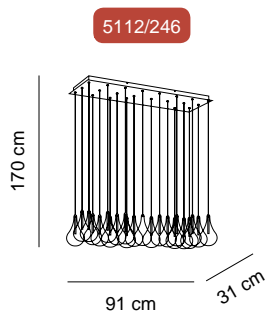

## Drop Led

Design by Cristian Cubiñá

Pantalla cristal borosilicato transparente  
**Shade borosilicate transparent glass**

Estructura hierro  
**Structure iron**

Lámparas Led incluidas, reemplazables, no regulables  
**Led lamps included, replaceable, not dimmable**

5112/246LED G4 24x1,1W 95lm 2700K CRI>80

5113/166LED G4 16x1,1W 95lm 2700K CRI>80

CE IP 20





## Drop Led

Design by Cristian Cubiñá

---

Pantalla cristal borosilicato transparente  
**Shade borosilicate transparent glass**

Estructura hierro cromado  
**Structure chromed iron**

Lámpara Led incluida, reemplazable, no regulable  
**Led lamp included, replaceable, not dimmable**

---

5111/016LED

 G4 Led 1,1W 95lm 2700K CRI>80

---

CE 

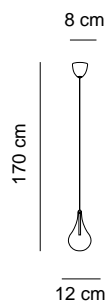

# Plafones

# Ceiling Lamps

Bath A Led / Deco / Drop S Led / Drop Downlight / Lens / Mizu / Moon / Stone  
/ SuperMoon / Tribeca









## Tribeca Downlight

Design Jordi LLopis

Pantalla alabastro  
**Shade alabaster**

Estructura hierro pintado negro texturizado  
**Structure black textured painted iron**

Driver incluido. **Driver included**

Led integrado  
**Integrated led**

No regulable **Not dimmable**

9800/018

Regulable mediante Triac **Dimmable by Triac**

9800/018RG

LED Seoul 4,5W 270lm 2700K

CE IP 20

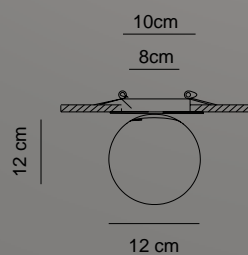







5110/196S

16 cm

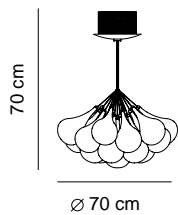

Ø 70 cm

5110/376S

20 cm

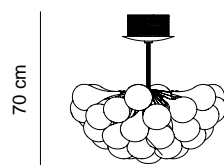

Ø 80 cm

## Drop S Led

Design by Cristian Cubiñá

Pantalla cristal borosilicato transparente  
**Shade borosilicate transparent glass**

Estructura hierro cromado / **Structure chromed iron**

Lámparas Led incluidas, reemplazables, no regulables  
**Led lamps included, replaceable, not dimmable**

5110/196S LED 19x G4 1,1W 95lm 2700K CRI>80

5110/376S LED 37x G4 1,1W 95lm 2700K CRI>80

CE IP 20



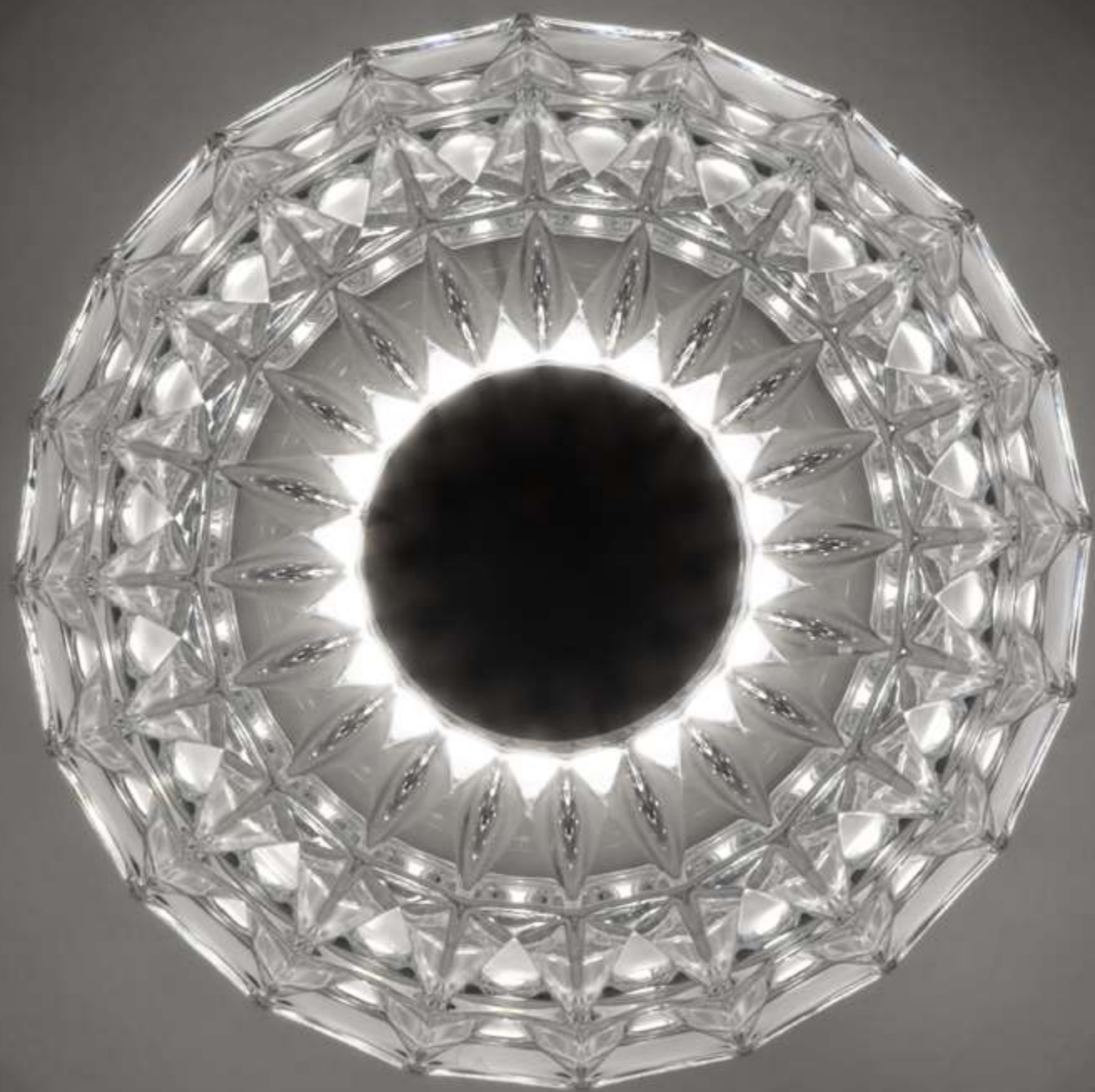



## Deco

Design by Cristian Cubiñá

Pantalla cristal prensado de Bohemia en acabado transparente  
**Shade pressed Bohemia crystal transparent glass**

Estructura hierro  
**Structure iron**

Lámpara no incluida **Lamp not included**

9550/011 Cromo **Chrome**

9530/011 Dorado **Gold**

 E14 LED

CE  IP 20

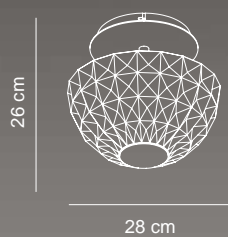









## Moon

Design by Josep Novell & Ernest Perera

Pantalla polietileno rotomoldeado texturizado  
**Shade rotomolded polyethylene textured**

Estructura hierro pintado blanco texturizado  
**Structure iron textured white**

No regulable  
**Not dimmable**

Led integrado  
**Integrated Led**

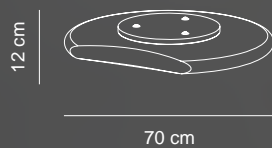

9850/011

LED Epistar 40W 3250lm 3000K

CE  







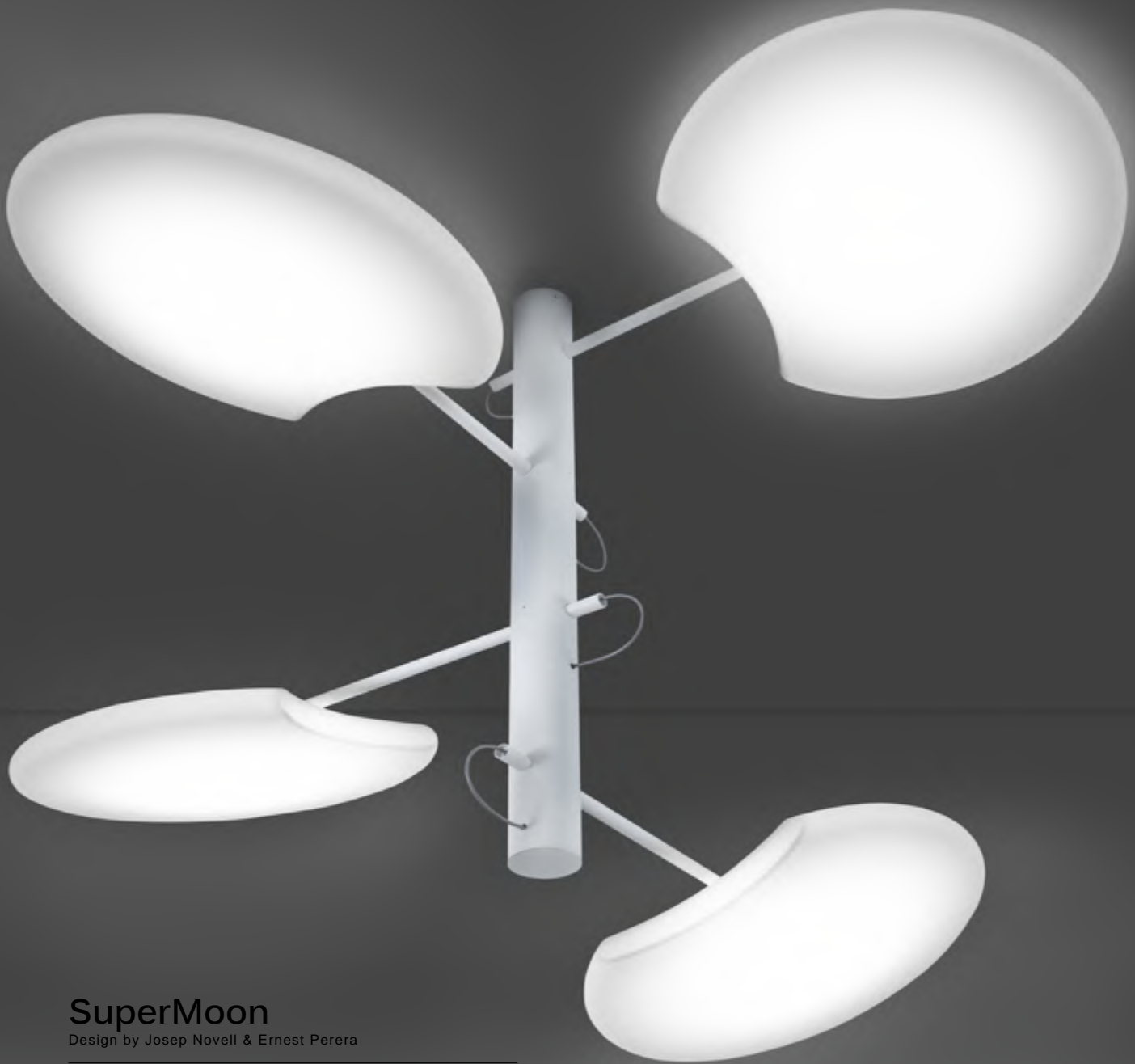

## SuperMoon

Design by Josep Novell & Ernest Perera

Pantalla polietileno rotomoldeado texturizado  
**Shade rotomolded polyethylene textured**

Estructura hierro pintado blanco texturizado  
**Structure iron textured white**

No regulable  
**Not dimmable**

Led integrado  
**Integrated Led**

9860/041

4 x LED Epistar 40W 3250lm 3000K

CE  

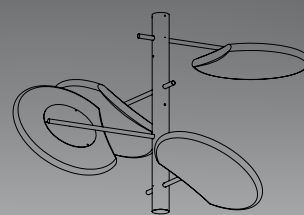

128 cm

200 cm









## Stone Led

Design by Josep Novell & Josep Puig

---

Pantalla polietileno rotomoldeado  
**Shade rotomolded polyethylene**

Estructura hierro pintado epoxi blanco mate  
**Structure epoxy matt white painted iron**

No regulable **Not dimmable.**

Led integrado  
**Integrated Led**

---

9300/036

LED Epistar 40W 3250lm 3000K

---

CE  

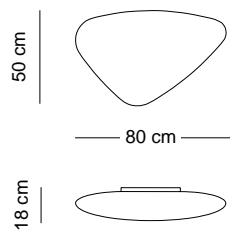

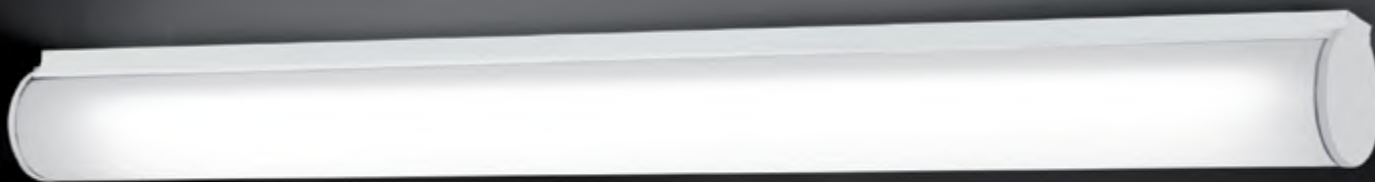

## Bath A Led

Design by Oriol Llahona

Pantalla policarbonato opal  
**Shade opal polycarbonate**

Estructura hierro pintado epoxi  
**Structure epoxy painted iron**

Regulable mediante Triac  
**Dimmable by Triac**

Led integrado  
**Integrated Led**

4420/061LED 14W 1350lm 60 cm blanco mate **matt white**  
4420/091LED 22W 2160lm 90 cm blanco mate **matt white**  
4420/121LED 30,8W 2970lm 120 cm blanco mate **matt white**  
  
4420/066LED 14W 1350lm 60 cm plata **silver**  
4420/096LED 22W 2160lm 90 cm plata **silver**  
4420/126LED 30,8W 2970lm 120 cm plata **silver**

Led 3000K

CE IP 23



60cm  
90 cm  
120 cm





## Mizu

Design by Ricard Ferrer

Pantalla cristal triplex opal  
**Shade opal blown glass**

Estructura hierro pintado epoxi  
**Structure iron epoxy painted**

Lámpara no incluida  
**Lamp not included**

9282/011 blanco mate **matt white**

9282/016 plata **silver**

9283/011 blanco mate **matt white**

9283/016 plata **silver**

9281/011 blanco mate **matt white**

9281/016 plata **silver**

 G9 LED

CE  

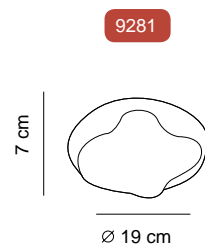
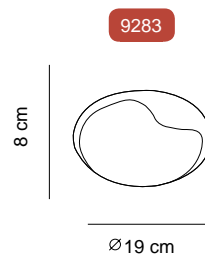
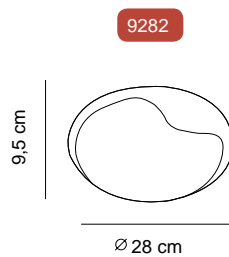







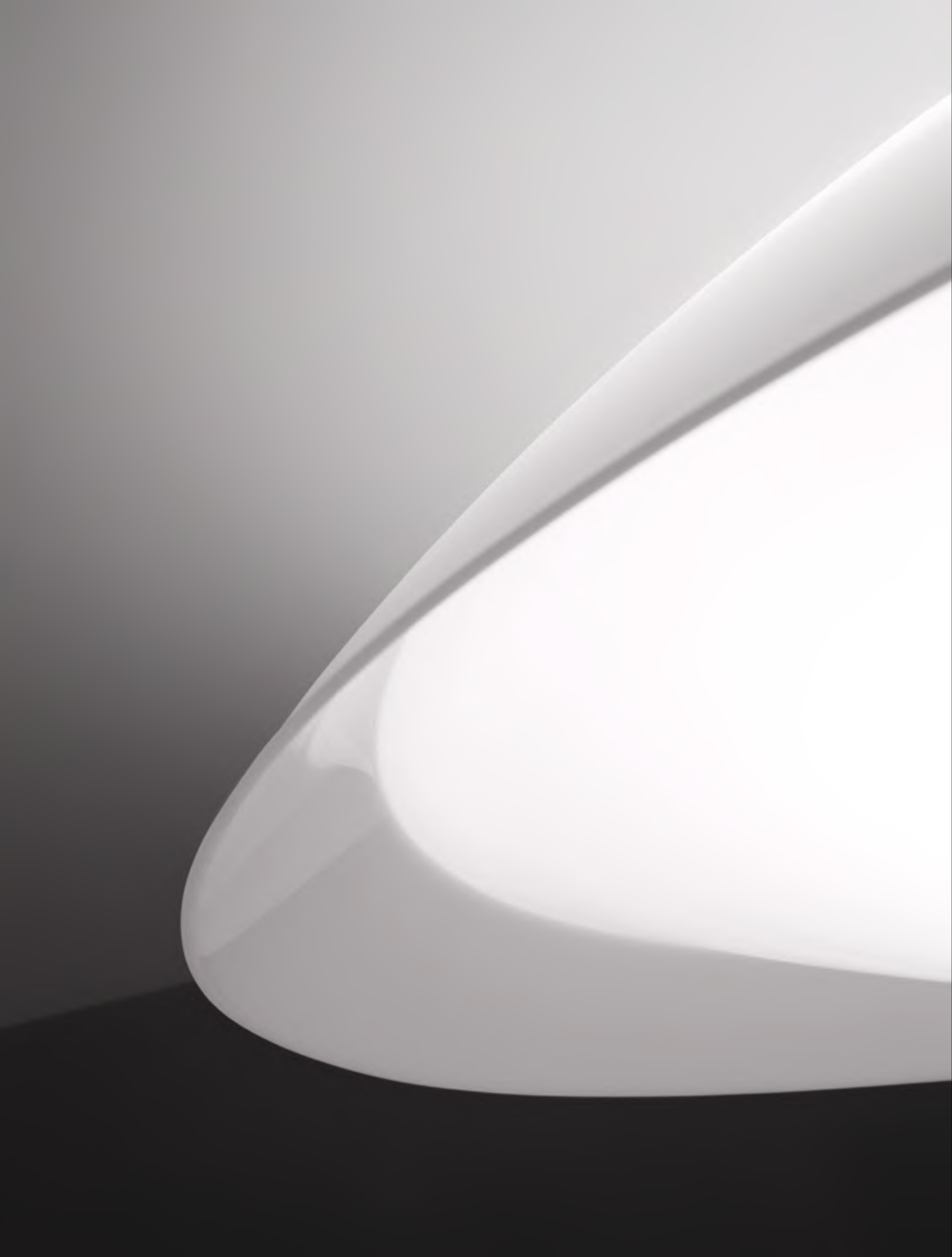





## Lens Led

Design by Cristian Cubiná

Pantalla de metacrilato blanco  
**Shade opal methacrylate**

Estructura hierro pintado epoxi blanco mate  
**Structure white epoxy painted iron**

No regulable  
**Not dimmable**

Led integrado  
**Integrated Led**

9290/011

LED Epistar 40W 3250lm 3000K

CE  

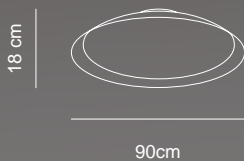



## Drop Downlight Led

Design Cristian Cubiñá

Pantalla cristal borosilicato transparente  
**Shade borosilicate transparent glass**

Foco empotrado. Estructura hierro cromado  
**Embedded downlight. Structure chromed iron**

Driver incluido  
**Driver included**

Lámpara incluida, no regulable y reemplazable  
**Lamp included, not dimmable and replaceable**

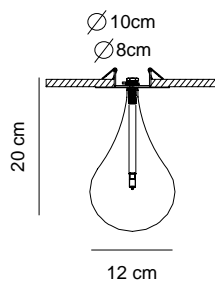

9111/016 LED

LED G4 1,1W 95lm 2700K CRI>80

CE IP20



# Apliques

# Wall Lamps

Bath A Led / Finger / Flat Led / Hotel / Madame / MiniFlat / Mizu / Paros Alabaster  
/ Tribeca









# Finger

Design by Cristian Cubiña

Estructura hierro pintado texturizado

**Structure textured epoxy painted iron**

Con interruptor **With switch**

Lámpara incluida, reemplazable, no regulable

**Lamp included, replaceable, not dimmable**

4020/011 blanco texturizado **textured white**

4020/012 corten texturizado **textured corten**

4020/018 negro texturizado **textured black**

G4 LED 1,1W 95lm 2700K CRI>80

CE IP 20

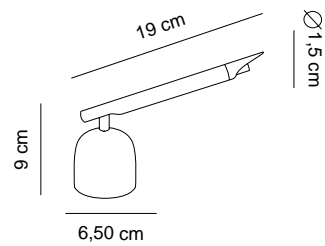



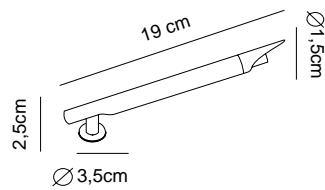

## Finger

Design by Cristian Cubiña

Estructura hierro pintado texturizado  
**Structure textured epoxy painted iron**

Sin interruptor **Without switch**

Lámpara incluida, reemplazable, no regulable  
**Lamp included, replaceable, not dimmable**

4021/011 blanco **white**  
4021/012 corten **corten**  
4021/018 negro **black**

G4 LED 1,1W 95lm 2700K CRI>80

CE IP 20







## Tribeca

Design by Jordi LLopis

Pantalla alabastro  
**Shade alabaster**

Estructura hierro pintado negro texturizado  
**Structure textured black painted iron**

Interruptor para el lector **Switch for the reading light**

Led integrado  
**Integrated Led**

No regulable **Not dimmable**

4800/028 un interruptor **one switch**

Regulable mediante Ttriac **Dimmable by Triac**

4800/028RG un interruptor **one switch**

LED Seoul 4.5W 270lm 2700K

LED Cree 3W 260lm 30° 3000K

CE IP 20

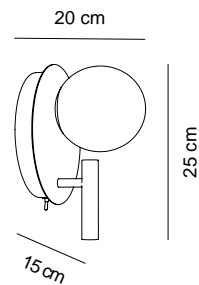



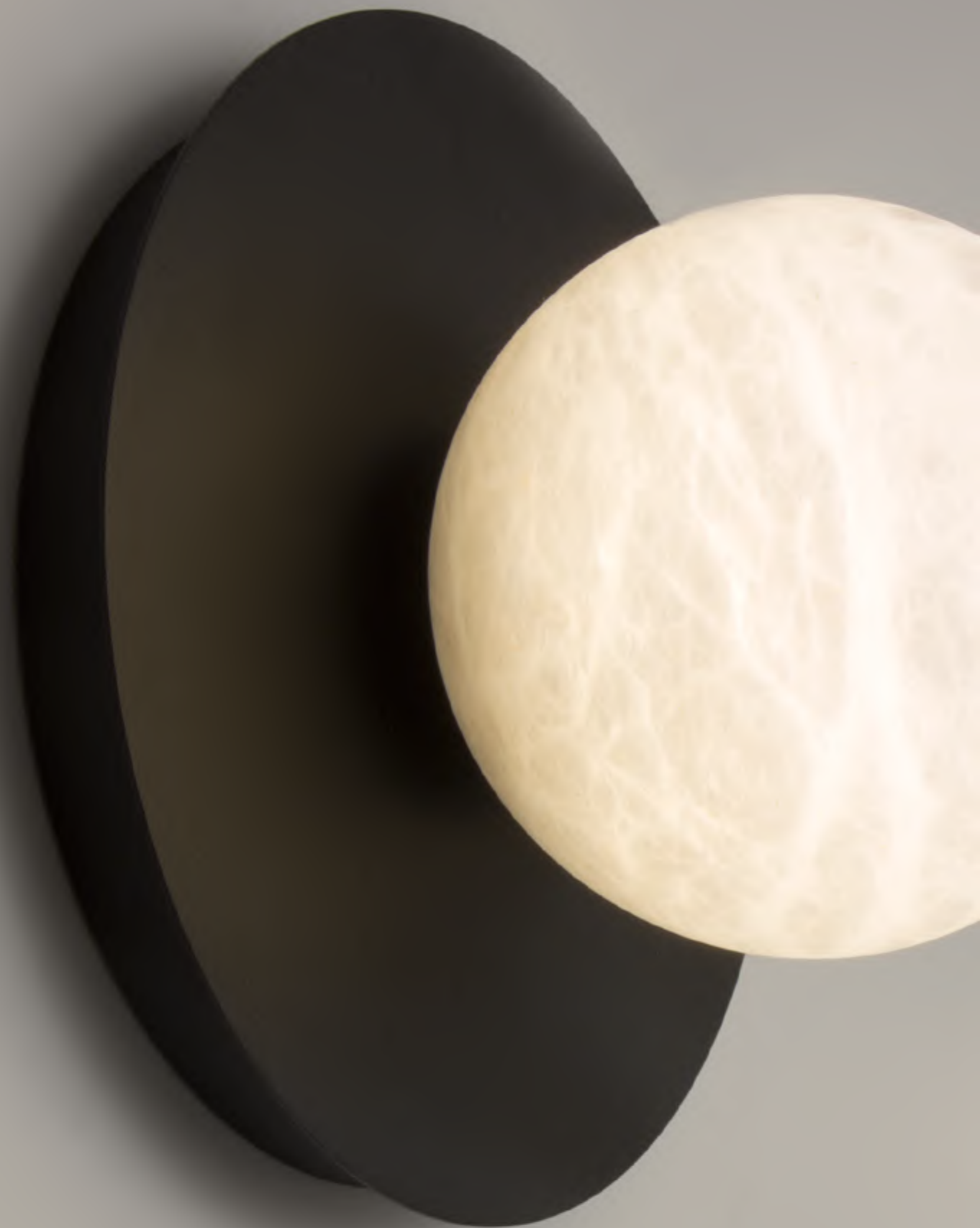







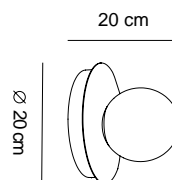

## Tribeca

Design by Jordi LLopis

---

Pantalla alabastro  
**Shade alabaster**

Estructura hierro pintado negro texturizado  
**Structure black textured epoxy painted iron**

Led integrado  
**Integrated Led**

---

No regulable **Not dimmable**

4800/018

Regulable **mediante Triac Dimmable by Triac**

4800/018RG

LED Seoul 4.5W 270lm 2700K

---

CE IP 20

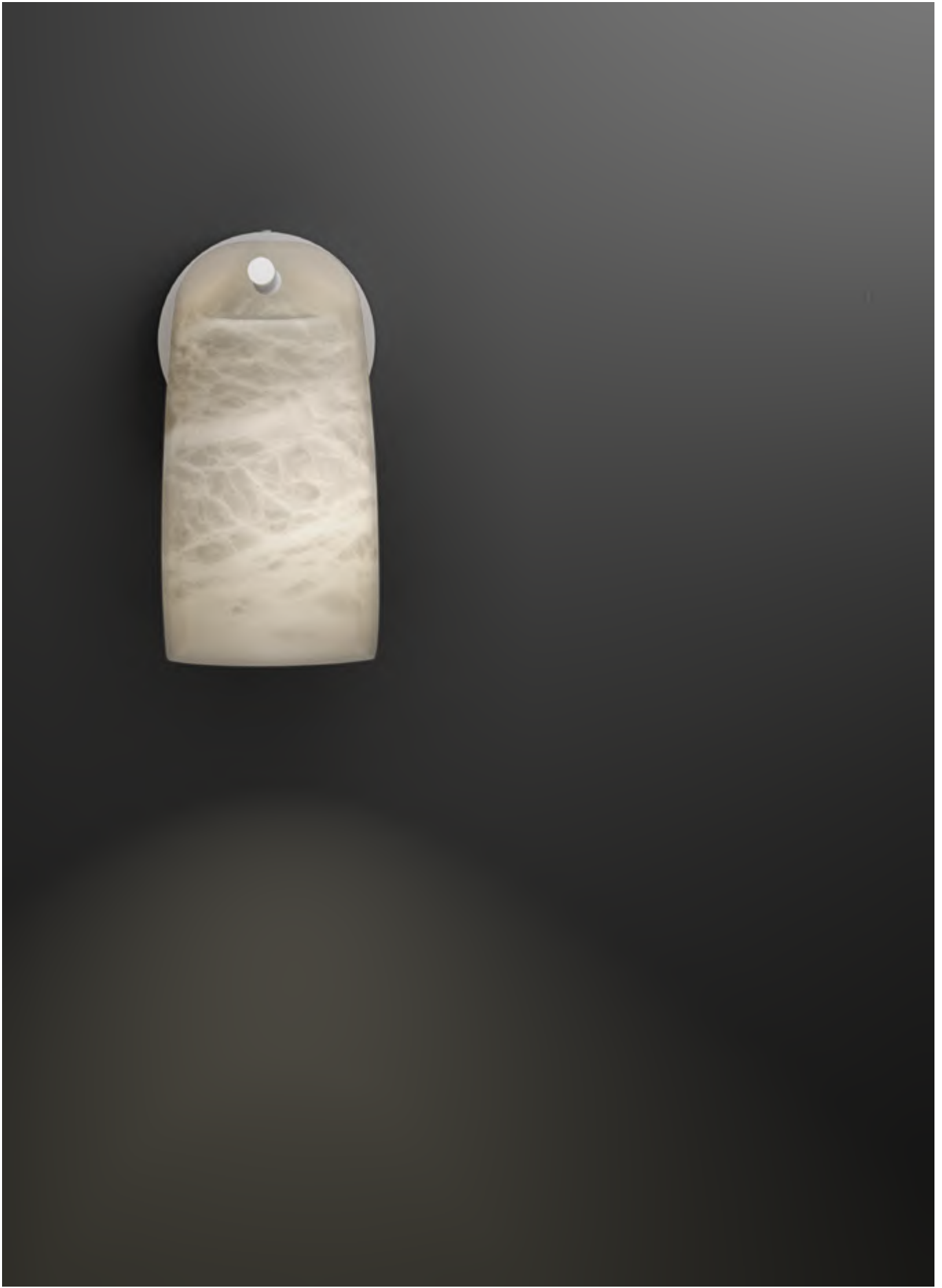

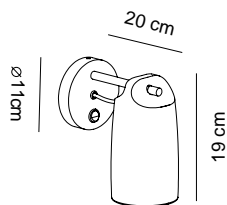

## Paros Alabaster

Design by Josep Novell & Ernest Perera

Pantalla **alabastro**  
**Shade alabaster**

Estructura hierro pintado blanco texturizado  
**Structure textured white painted iron**

Con interruptor With switch

Lámpara no incluida, reemplazable  
**Lamp not included, replaceable**

4270/011

 E14 LED

CE  



- MAKING IT
- LOST FISH
- NEW URBAN HOUSING
- Genève in France
- ALEXEY BRODOVITCH I
- ANTIQUAIRES
- WORLD CHAMPIONS
- Optimal Living Today
- NOODLES

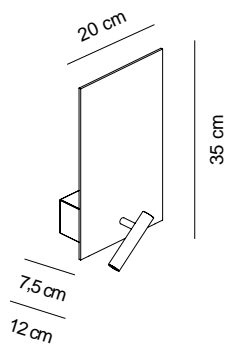

## Flat Led

Design by Josep Novell & Ernest Perera

Estructura hierro  
**Structure iron**

Con interruptor para el lector o dos interruptores  
**With switch for the reading light or two switches**

Led integrado en el lector  
**Integrated LED included for the reading light**

4416/011 blanco mate, un interruptor **matt white, one switch**

4416/018 negro mate, un interruptor **matt black, one switch**

4416/211 blanco mate, un interruptor **matt white, two switch**

4416/218 negro mate, un interruptor **matt black, two switch**

 E27 LED

LED Cree 3W 260lm 30° 3000K

CE 







## MiniFlat

Design by Cristian Cubiñá

Estructura hierro  
**Structure iron**

No regulable  
**Not dimmable**

Led integrado  
**Integrated Led**

4419/011 blanco texturizado **textured white**

4419/018 negro texturizado **textured black**

4419/016 níquel satinado **satín nickel**

4413/011 blanco texturizado **textured white**

4413/018 negro texturizado **textured black**

4413/016 níquel satinado **satín nickel**

4414/011 blanco texturizado **textured white**

4414/018 negro texturizado **textured black**

4414/016 níquel satinado **satín nickel**

LED Cree 3W 260lm 30° 3000K

CE  IP 20

4419

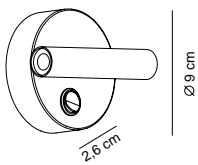

4414

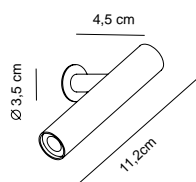

4413

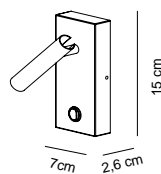

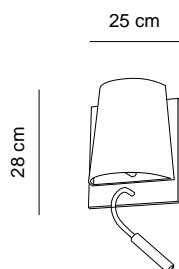

## Hotel

Design by Cristian Cubiñá

---

Pantalla algodón negra  
**Shade black cotton**

Estructura hierro pintado epoxi champagne  
**Structure epoxy champagne painted iron**

Con interruptor para el lector  
**With switch for the reading light**

Led integrado  
**Integrated Led**

---

4540/018

 E27 LED

LED 3W 30° 4000K

---

CE 







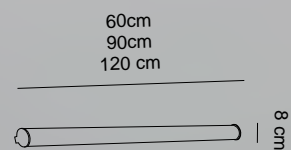

## Bath A Led

Design by Oriol Llahona

Pantalla policarbonato opal  
**Shade opal polycarbonate**

Estructura hierro pintado epoxi  
**Structure epoxy painted iron**

Regulable mediante Triac  
**Dimmable through Triac**

Led integrado,  
**Integrated Led**

4420/061LED 14W 1350lm 60 cm blanco mate **matt white**  
4420/091LED 22W 2160lm 90 cm blanco mate **matt white**  
4420/121LED 30,8W 2970lm 120 cm blanco mate **matt white**  
  
4420/066LED 14W 1350lm 60 cm plata **silver**  
4420/096LED 22W 2160lm 90 cm plata **silver**  
4420/126LED 30,8W 2970lm 120 cm plata **silver**

Led 3000K

CE IP 23



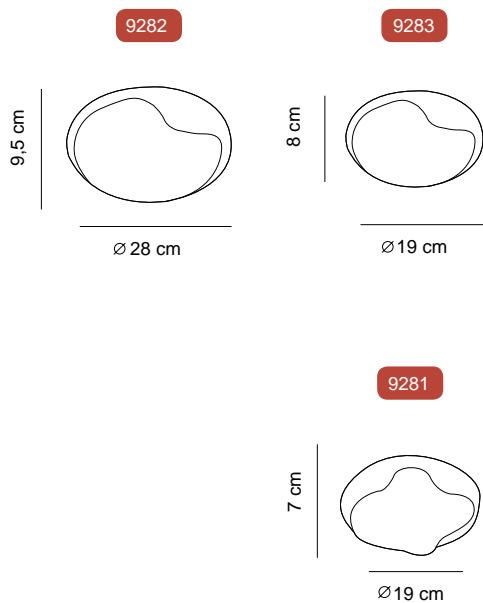

## Mizu

Design by Ricard Ferrer

Pantalla cristal triplex opal  
**Shade opal blown glass**

Estructura hierro pintado epoxi  
**Structure iron epoxy painted**

Lámpara no incluida  
**Lamp not included**

9282/011 blanco mate **matt white**

9282/016 plata **silver**

9283/011 blanco mate **matt white**

9283/016 plata **silver**

9281/011 blanco mate **matt white**

9281/016 plata **silver**

 G9 LED

CE  IP 23













## Madame

Design by Oriol Llahona

Estructura hierro pintado epoxi  
**Structure iron epoxi painted**

Con interruptor  
**With switch**

Lámpara no incluida  
**Lamp not included**

4650/016 blanco mate plata **mat white silver**

4650/018 negro mate dorado **mat black gold**

 G9 LED

CE  

4650/016 4650/018

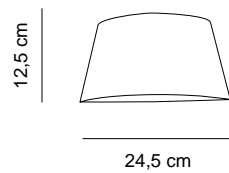

# Exterior Outdoor

Stone Out Led / Tiny









## Tiny

Design by Jose Novell & Josep Puig

Estructura latón acabado níquel satinado  
**Structure brass satin nickel finished**

Pantalla polietileno rotomoldeado / Lámpara no incluida  
**Shade rotomolded polyethylene/Lamp not included**

4370/016

4371/016

4372/016

 E27 LED

CE  

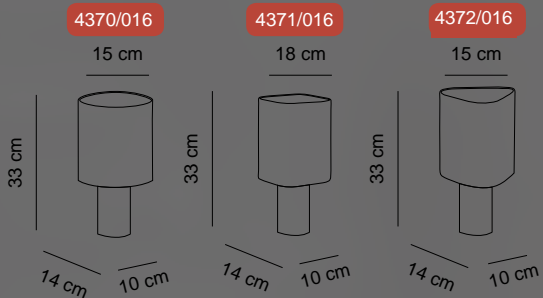

## Tiny

Design by Josep Novell & Josep Puig

Estructura latón acabado níquel satinado  
**Structure brass satin nickel finished**



Pantalla polietileno rotomoldeado / Lámpara no incluida  
**Shade rotomolded polyethylene/Lamp not included**

2370/016

2371/016

2372/016

 E27 LED

CE  

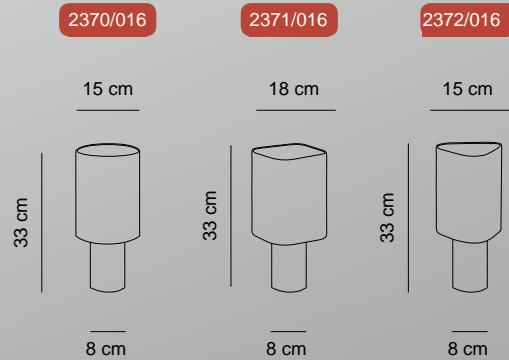

# Tiny

Design by Josep Novell & Josep Puig

Estructura latón acabado níquel satinado  
**Structure brass satin nickel finished**

Con 4mt cable con funda de neopreno y clavija Schuko  
**Structure With 4mt neoprene cable with Shucko plug**

Lámpara no incluida  
**Lamp not included**

2375/016

2376/016

2377/016

 E27 LED

CE  

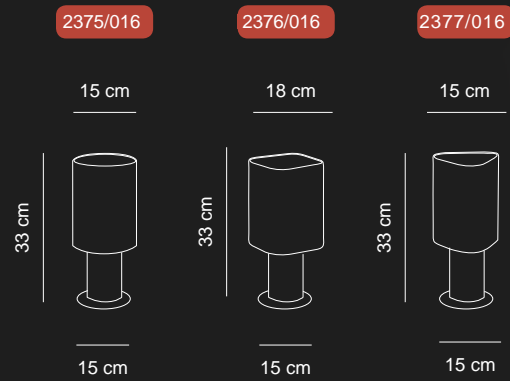



## Stone Out Led

Design by Josep Puig & Josep Novell

Pantalla polietileno rotomoldeado  
**Shade rotomolded polyethylene**

Estructura acero inoxidable pintado blanco mate  
**Structure matt white panted stainless steel**

No regulable  
**Not dimmable**

Led integrado  
**Integrated Led**

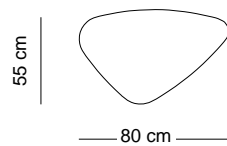

9330/036

LED Epistar 40W 3250lm 3000K

CE  









## Stone Out Led

Design by Josep Puig & Josep Novell

Pantalla polietileno rotomoldeado  
**Shade rotomolded polyethylene**

Estructura acero inoxidable pulido/aluminio  
**Structure polished stainless steel/aluminium**

**No regulable**  
**Not dimmable**

Led integrado  
**Integrated Led**

4 metros de cable con funda de neopreno y clavija Schuko  
**4 meters of neoprene cable with Schuko plug**

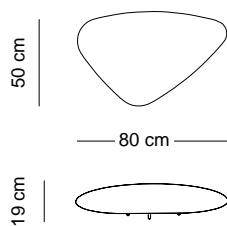

2300/036

LED Epistar 40W 3250lm 3000K

CE  

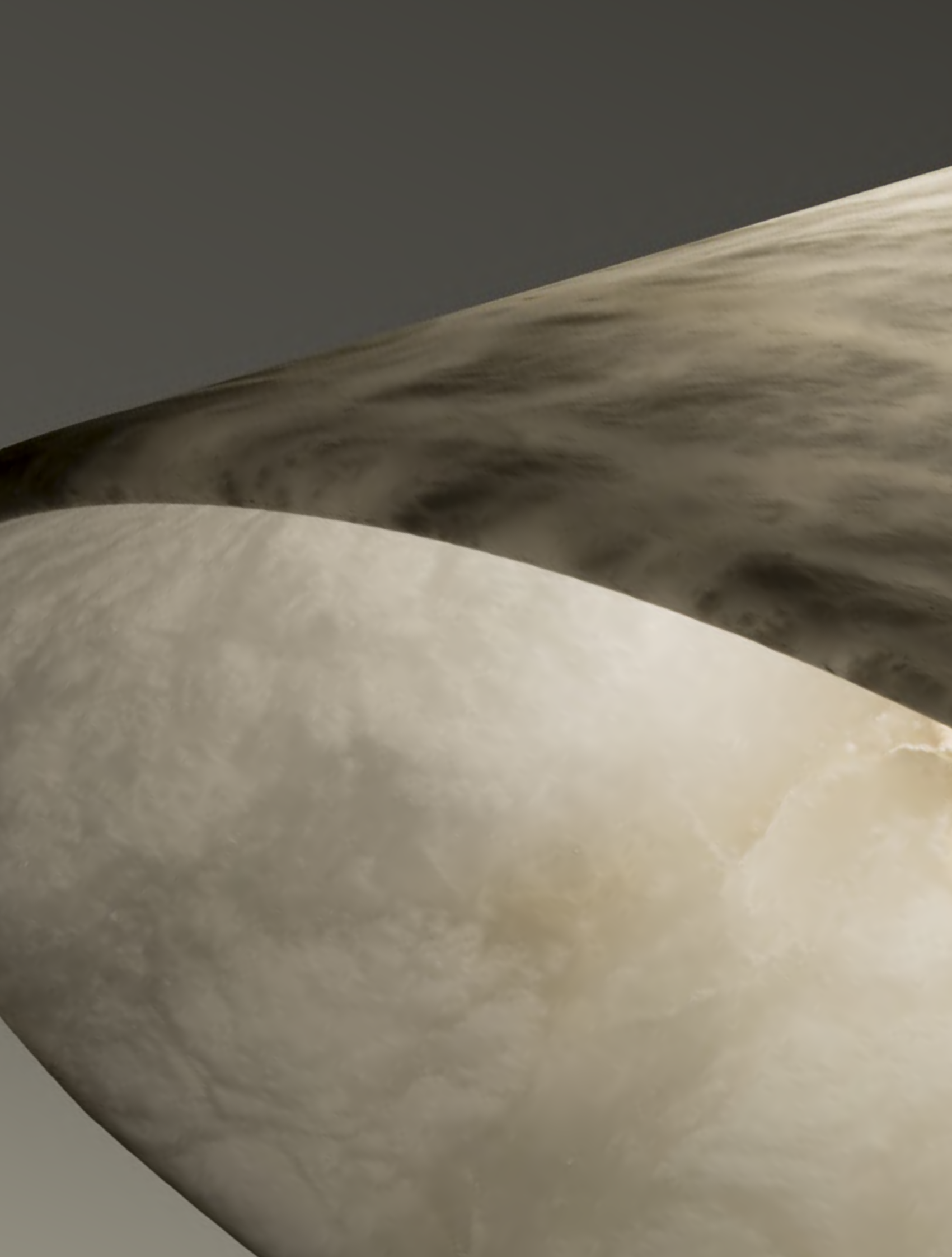

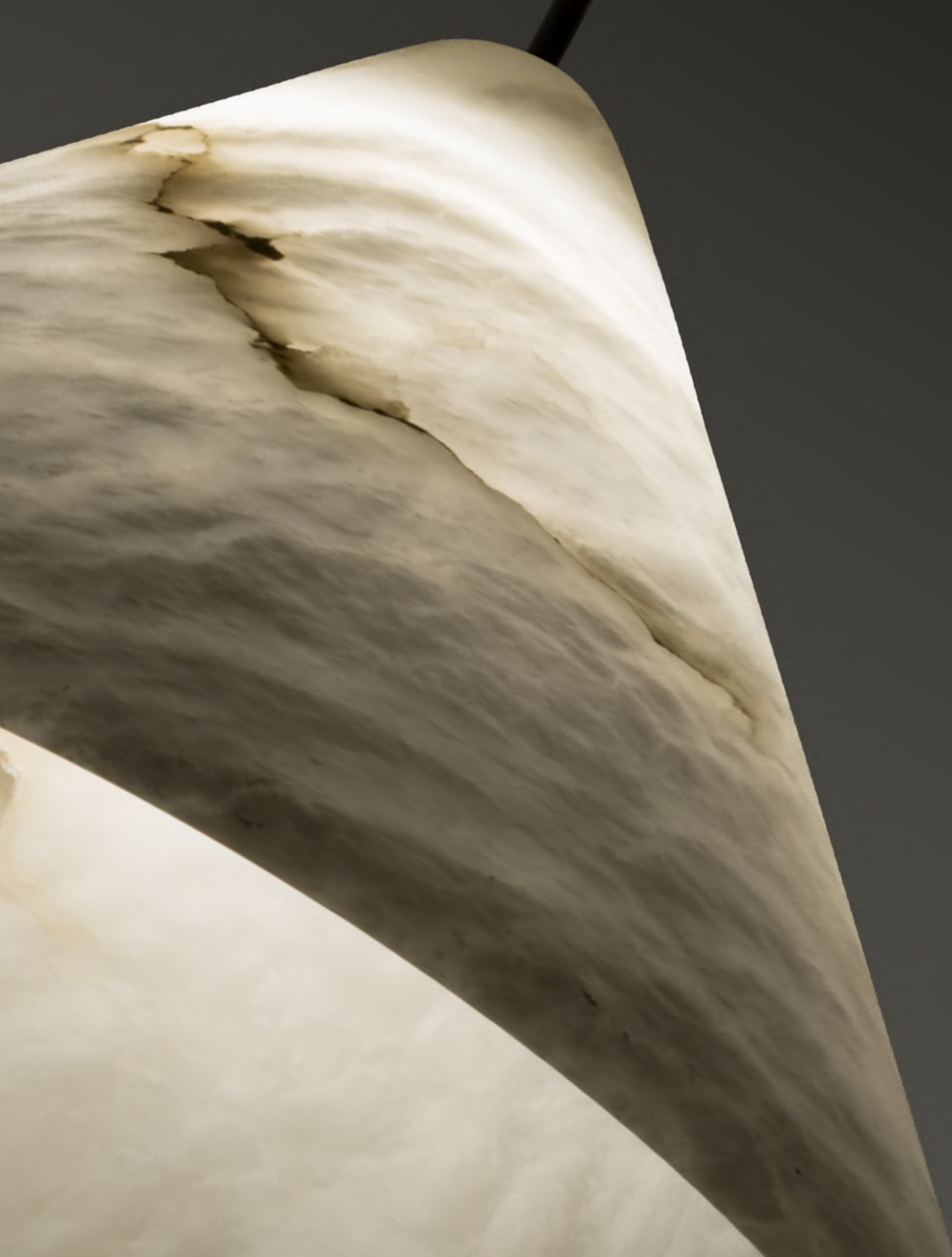

Pintura / *Painted*

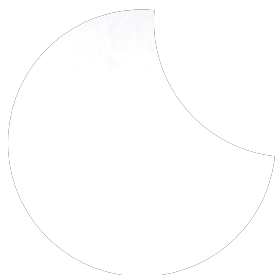

blanco mate  
***matt white***



plata  
***silver***

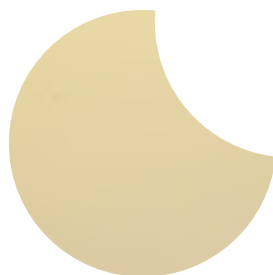

champagne  
***champagne***

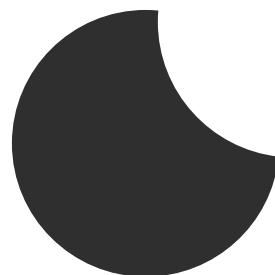

negro mate  
***matt black***

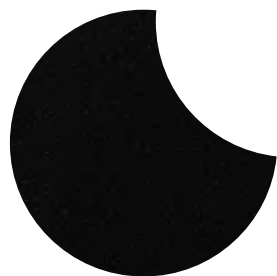

negro texturizado  
***textured black***

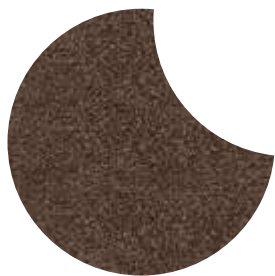

corten texturizado  
***textured corten***

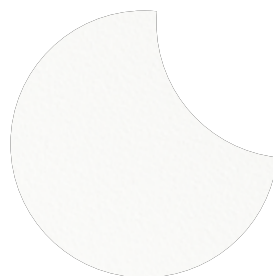

blanco texturizado  
***textured white***

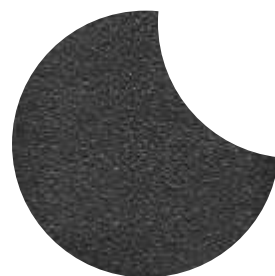

antracita texturizado  
***textured anthracite***

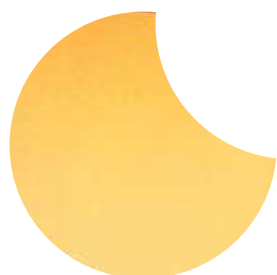

dorado *mate*  
***matt gold***



negro brillante  
***glossy black***

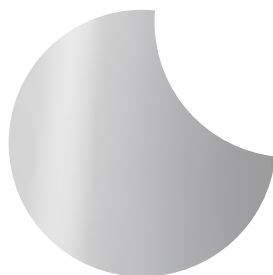

blanco brillante  
***glossy white***

Cristal / *Glass*



transparente Deco  
***transparent Deco***



negro Soft  
***black Soft***



rosa Soft  
***pink Soft***



opal  
***opal***



borosilicato estriado  
***fluted borosilicate***



borosilicato transparente  
***transparent borosilicate***

Baño electrolítico / **Electroplated**



dorado satinado  
*satin gold*

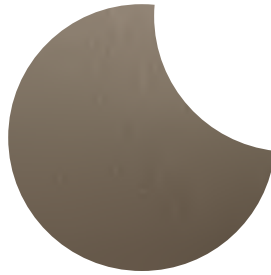

níquel satinado  
*satin nickel*



bronce satinado  
*satin bronze*

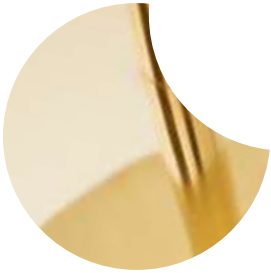

latón pulido brillo  
*polished brass*

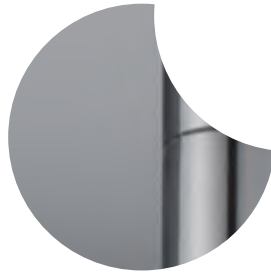

romo  
*chrome*



dorado brillo  
*polished gold*

Anodizado / **Anodized**

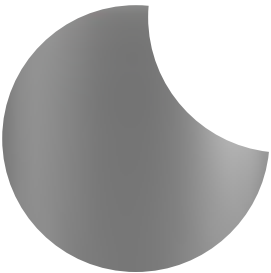

plata mate  
*matt silver*

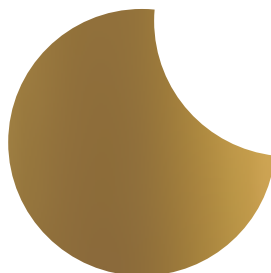

dorado mate  
*matt gold*



latón arenado  
*sandblasted brass*

Pantallas de tela / **Textile shades**

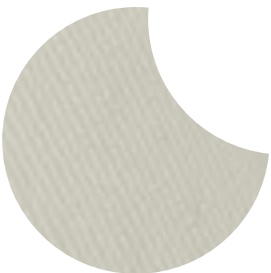

polipropileno  
*polypropylene*

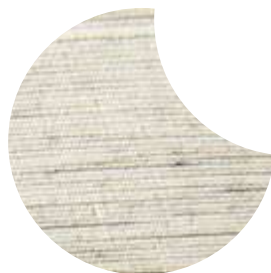

almadén plata  
*silver almaden*



algodón negro  
*black cotton*

Otros Materiales / **Other materials**



polietileno rotomoldeado  
*rotomolded polyethylene*

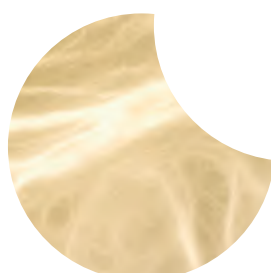

alabastro  
*alabaster*



metacrilato opal  
*opal methacrylate*



madera de Iroco  
*iroco wood*

ALMA light  
Barcelona





ALMA LIGHT se reserva el derecho a realizar modificaciones de producto sin previo aviso.  
Catálogo realizado con papel ecológico, recíclelo, gracias

***ALMA LIGHT reserves the right to modify the products without prior notice.  
Catalogue printed with ecological paper, please recycle it***

Fotografía / **Photography**

Tribeca USB

Cristina Gual Busqué,  Racó19, Sant Vicenç de Montalt (Spain)

Andrea Elballe & Pau Larrea,  La Rania, Vidrà (Spain)

Totem, Tribeca, Star

 Cubiña, Barcelona (Spain)

 Curvas fotométricas disponibles en [www.almalight.com](http://www.almalight.com)  
***Photometric curves available on [www.almalight.com](http://www.almalight.com)***

Para acabados / colores distintos de los artículos catalogados, diseños especiales o formatos customizados, contactar con ALMA LIGHT  
***For finishes/colors different from the ones on this catalog, special designs or customized formats, please contact ALMA LIGHT***





# ALMIGHT

---

**Oficina central y almacén**  
**Head office and warehouse**

Cristobal de Moura 195-197  
08019 Barcelona [Spain]

T [+34] 933 085 346  
T [+34] 932 660 775  
info@almight.com

Follow us in Facebook  
Instagram & Pinterest  
@almightbarcelona

**[www.almight.com](http://www.almight.com)**

---

