

# The New Collection

---

happen, boomerang chill, pío-pío,  
ace, chat, rock, tea, mandarinas.

---

**SANCAL**



## **The New Collection**

Esta colección es de 2010. Para evitar inconvenientes, revise la tarifa actual para comprobar la vigencia del producto antes de solicitarlo.

Los siguientes modelos han sido completamente descatalogados:

**Pío-pío**  
**Ace**

This collection is from 2010. To avoid disappointment, please check our latest price list to see if a specific configuration is still in production before ordering.

The following models have been completely discontinued:

**Pío-pío**  
**Ace**

*HAPPEN, 04-29*

*BOOMERANG CHILL, 30-37*

*PÍO-PÍO, 38-47*

*ACE, 48-57*

*CHAT, 58-65*

*ROCK, 66-75*

*TEA, 76-91*

*MANDARINAS, 92-95*

*TECHNICAL INDEX, 96-108*



## estudihac jmferrero

Valencia, 2003

Estudihac está liderado por José Manuel Ferrero, quien tras una intensa experiencia profesional junto a Oscar Tusquets crea su propio estudio de diseño industrial e interiorismo.

Tras la nominación a los International Designs Awards de Elle Deco, 2009 ha sido su año, pues el estudio ha recibido dos premios ADCV y una selección a los premios Delta de la mítica fundación ADI-FAD.

El estudio colabora desde hace años con Toyota Japón en el diseño de los interiores de la serie iQ. Más allá de la automoción, en el sector del habitat, la carrera del estudio está en plena expansión con los proyectos realizados para Vondom, Punt Mobles, Porcelanosa, Gandia Blasco, Do+Ce y ahora también para Sancal.

Estudihac is led by Jose Manuel Ferrero who, after an intense work experience with Oscar Tusquets, created his own industrial and interior design studio.

After the nomination in the Elle Deco International Designs Awards, 2009 was his year, since the studio has received two ADCV awards and a selection for the Delta awards for the legendary foundation ADI-FAD.

The studio has been collaborating for years with Toyota Japan in the design of the interior of the iQ series. Beyond the automotive, in the habitat sector, the studio's career is booming - with projects

for Vondom, Punt Mobles, Porcelanosa, Gandia Blasco, Do + Ce and now also for Sancal.

Estudihac est dirigé par Jose Manuel Ferrero, qui après une intense expérience professionnelle avec Oscar Tusquets créa son propre bureau d'architecture d'intérieur et design industriel.

Après une nomination aux International Design Awards de Elle Deco, 2009 a suivi une année pleine de succès, en effet le bureau d'études a reçu deux prix ADCV en plus d'une sélection aux prix Delta de la mythique fondation ADI-FAD.

Le studio collabore depuis de nombreuses années avec Toyota Japon, en dessinant les intérieurs de la Série IQ. Au-delà de l'automatisation, dans le secteur de l'habitat, la carrière du studio est en pleine expansion avec les projets réalisés pour Vondom, Punt Mobles, Porcelanosa, Gandia Blasco, Do+Ce et maintenant Sancal.

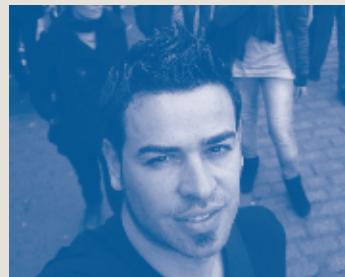

## rafa garcía

Yecla, 1976

Rafa forma parte del corazón creativo de Sancal. Reflexionando sobre las necesidades más íntimas de cada hogar, para esta temporada nos propone dos nuevos must: el modular Happen y las mesas Rock. Para Sancal también ha proyectado el inconfundible Play, el ligero sofá Lineal y el cómodo modular Up!

Rafa is part of the creative heart of Sancal. Reflecting the deepest needs of every home, he offers us two new must-haves for this sea-

son: the modular Happen and the Rock tables. He has also designed the unmistakable Play for Sancal, the lightweight Lineal sofa and the comfortable modular Up!

Rafa fait partie du cœur créatif de Sancal. En réfléchissant sur les nécessités intimes de chaque foyer, il nous propose cette année deux nouveaux must : le fauteuil modulaire Happen et les tables Rock. Il a également dessiné le très reconnaissable Play, le canapé léger Lineal et le confortable modulaire Up!



## a-cero

Madrid, 1996

A-cero es el estudio de arquitectura fundado y dirigido por Joaquín Torres. Su nombre es un juego de palabras a partir del tipo de papel empleado en planimetría, el DIN A-0.

Desde su sede en La Finca, A-cero ha proyectado las más espectaculares edificaciones, entre las que, a parte de las numerosas viviendas privadas de lujo para célebres personajes, destaca la Torre Wave, que se eleva sobre el agua en The Heart of Europe de Dubai.

La colección de asientos Ace es uno de los primeros artículos de mobiliario diseñados por el estudio, que anuncia sus próximas colaboraciones con destacadas firmas.

A-cero is the architectural studio founded and directed by Joaquin Torres. The name is a play on words that comes from the type of paper used in planimetry, DIN A-0.

From its headquarters in La Finca, A-cero has designed the most spectacular buildings, among which, apart from the many private luxury homes for famous characters, we underscore the Wave Tower, which rises above the water in The Heart of Europe in Dubai.

Ace seating collection is one of the first ranges of furniture designed by the studio, which announces its forthcoming collaborations with leading brands.

A-cero est le bureau d'architecture créé et dirigé par Joaquin Torres. Il tire son nom du papier utilisé en planimétrie, le DIN A-0.

De son bureau de La Finca, A-cero a projeté des constructions spectaculaires, parmi lesquelles, de nombreuses résidences privées, très luxueuses destinées à des personnages célèbres, et la remarquable Wave Tower, qui jailli de l'eau dans The Heart of Europe à Dubai.

La collection de sièges Ace est une des premières pièces de mobilier dessinée par le bureau d'études, qui annonce aussi une future collaboration avec des sociétés très en vue comme.



## Quim Larrea

Córdoba, 1957

Quim es uno de los pesos pesados del diseño español. Premio Nacional de Diseño a toda una carrera, arquitecto, diseñador y periodista, en los años 80' funda y dirige la revista Ardi junto a Juli Capella, desde la cual promueven interesantes iniciativas que han dado alas a la cultura del diseño

en made in Spain. Actualmente preside el Centro de Diseño Andaluz y dirige un estudio enfocado tanto a la arquitectura como al diseño industrial. Fruto de esta actividad en la que también colabora Katherine Bedwell, nacen los bancos Agrada para Onn Outside y la colección Boomerang para Sancal, un arriesgado y exitoso proyecto con resultados extremadamente polivalentes.

Quim is one of the heavyweights of Spanish design. He holds the National Design Award for his career as an architect, designer and journalist. In the '80s he founded and directed the magazine Ardi with Juli Capella - from which he promoted interesting initiatives that have given wings to the culture of design made in Spain. Currently he chairs the Andalusian Design Center and directs a study focused on both architecture and industrial design. As a result of this activity, in which Katherine Bedwell also collaborates, the bench seating named Agrada was born, for Onn Outside; also the Boomerang collection for Sancal - an edgy and successful project with extremely versatile results

Quim est un poids lourd du design Espagnol. Premier Prix National du Design, pour toute sa carrière, architecte, designer et journaliste, dans les années 80 il lance et dirige avec Juli Capella, la revue ARDI, ensemble, ils promotionnent des initiatives intéressantes qui ont donné des ailes à la culture du design made in Spain. Actuellement il préside le Centre du Design Andalous et dirige un bureau d'études focalisé vers l'architecture et le design industriel. Fruit de cette activité dans laquelle collabore Katherine Bedwell, sont dessinés les bancs Agrada pour Onn Outside et la collection Boomerang pour Sancal, un projet audacieux, rencontrant le succès en obtenant des résultats extrêmement polyvalents.



**odosdesign**  
Valencia, 2003

Este multidisciplinar estudio está constituido por Ana Segovia, María Mengual, Luis Calabuig y Eva Cerveró. Además de la silla Liné y del aclamado modular 1+1, que proyectaron para la anterior colección de Sancal, han diseñado para firmas tan prestigiosas como Gandía Blasco o Do+Ce. Con la sombrilla Ensombra recibieron en 2007 el primer premio de los británicos Grand Design Awards y una mención especial en los premios Delta. Además, el pasado año recibieron un ADCV de plata por la silla Basic de Gandía Blasco.

This multidisciplinary studio is constituted by Ana Segovia, María Mengual, Luis Calabuig and Eva Cerveró. Apart from the Line chair and the acclaimed modular 1+1 which the studio projected for the previous Sancal collection, they have designed for other prestigious companies such as Gandía Blasco and Do+Ce. With the Ensombra parasol they received the top award at the Grand Design Awards in 2007 and a special mention at the Delta awards. Moreover, last year they received a silver ADCV with the Basic chair for Gandía Blasco.

Ce bureau d'étude multidisciplinaire est formé par Ana Segovia, María Mengual, Luis Calabuig et Eva Cerveró. En plus de la chaise Line et du modulaire à succès 1+1, qu'ils ont dessiné pour l'avant dernière collection de Sancal, ils ont aussi travaillé pour des sociétés prestigieuses comme Gandía Blasco ou Do+Ce. Avec le parasol Ensombra ils ont reçu en

2007 le premier prix des britanniques du Grand Design Awards et une mention spéciale pour les prix Delta. De plus l'année passée ils ont été primés avec un ADCV d'argent pour la chaise Basic de Gandía Blasco.

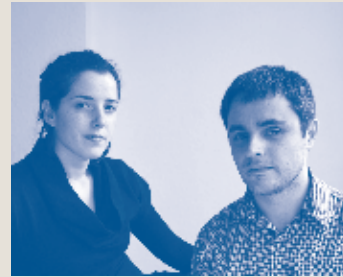

**nadadora**  
Valencia, 2006

Nadadora fue fundado por Isaac Piñeiro y Cristina Alonso. Su trabajo parte de la necesaria relación entre las diferentes disciplinas del diseño. En sus proyectos y forma de trabajar prima la honestidad conceptual y la sencillez; comunicar a primera vista para desarrollar proyectos cercanos. Nadadora ha colaborado con empresas como Lavandera, Sagen Ceramics, La Murrina, Ferrero Italia, Serralunga o Balvi.

Recientemente, el estudio ha sido premiado por Corolla, un diseño proyectado para Nutella y seleccionados para la exposición Serie Fuori Serie de la Triennale Design Museum de Milán. Nos sorprenden ahora con la colección Chat, que no dejará indiferente.

Nadadora was founded by Isaac Piñeiro and Cristina Alonso. Their work comes from a relationship which is necessary between the different disciplines of design. The precedence in their projects and way of working ensures conceptual honesty and simplicity; it is to communicate spontaneously in order to develop immediate projects. Nadadora has collaborated with firms such as Sagen Ceramics, La Murrina, Ferrero Italia, Serralunga or Balvi.

The studio has recently been given

an award by Corolla - a projected design for Nutella; they have also been selected for the exhibition Serie Fuori Serie by the Triennale Design Museum of Milano. They have surprised us yet again with the Chat collection, one cannot remain indifferent.

Nadadora a été fondée par Isaac Piñeiro et Cristina Alonso. Son travail démarre de la relation indispensable entre les différentes disciplines du design. Dans ses projets et formes de travail prime l'honnêteté conceptuelle et la simplicité : communiquer à première vue pour développer des projets familiers. Nadadora a collaboré avec des sociétés comme Lavandera, Sagen Ceramics, La Murrina, Ferro Italia, Serralunga ou Balvi.

Récemment, le bureau d'études a été primé par Corolla, un projet dessiné pour Nutella et sélectionné par l'exposition Serie Fuori Serie de la Triennale Design Museum de Milan. Nous serons séduits par la collection Chat, qui ne manquera pas de nous surprendre.



**elena castaño-lópez**  
Yecla, 1984

Ilustradora y diseñadora gráfica, Elena hace sus pinitos en el mundo del diseño industrial con esta suave propuesta.

Illustrator and graphic designer Elena has successfully dabbled in the world of industrial design with this softer project.

Designer graphique, Elena fait ses premiers pas dans le monde du design industriel avec ce projet tout en douceur.

# HAPPEN

rafa garcía, 2010

Si pensamos en cómo representar un sofá frente a una hoja en blanco, seguramente dibujaríamos algo muy parecido a este modelo, pues **Happen** es lo que surge, el paradigma, la esencia de aquello que hoy día representa un sofá.

**Happen** nace con el propósito de ser normal, si bien ha sido concebido para ir más allá de modas pasajeras. Formas atemporales para trascender. **Rafa García**, no ha intentado reinventar nada, sólo practicar el diseño teniendo muy en cuenta las proporciones, los materiales, las costuras y la capacidad de crear composiciones dinámicas; siempre con el convencimiento de que cada detalle, por pequeño que sea, es importante.

El proyecto huye de gestos exaltados y no se sostiene mediante trucos, sino apelando a formas neutras y a la simplicidad como base del desarrollo de la colección. Es esta pretensión de normalidad lo que diferencia el producto. Detalles estudiados sin artificios. De este modo, Rafa se adhiere a la filosofía que han promovido Naoto Fukasawa y Jasper Morrison a través de la exposición *Super Normal. Sensations of the Ordinary*.

**Happen** propone una fina base con forma de L en la cual ir integrando elementos. Más que un puzzle, se trata de un extenso programa modular, más próximo al sistema de componibles del mueble que al de la tapicería.

Frente a la premisa de ofrecer una extensa modularidad con la que trabajar y participar en todo tipo de espacios, el reto estaba en encontrar piezas originales para satisfacer nuevas necesidades, como, por ejemplo: agregar a la estructura del sofá una superficie donde dar apoyo diferentes objetos; varios tipos de brazo; un módulo con doble fondo; módulos terminales y chaises longues de distinto formato.

También nos permite crear ángulos con gran número de piezas. Sin mencionar las piezas auxiliares: pufs que funcionan sueltos e integrados en una composición o que se fusionan con unas mesas tapizadas para resolver dos aplicaciones en una. A toda esta modularidad, debemos añadir una opción no menos importante: la dualidad de altura para las almohadas de respaldo de 74 y 84 centímetros.

Los detalles que no se ven son todavía más importantes. La confección de las almohadas de asiento está realizada a partir de una composición especial de poliuretano, a la que añadimos una densa capa de viscoelástica de 6 cm. de espesor en la parte superior.

*¡Misión cumplida!*

If we think about how to represent a sofa in a white sheet, we would surely draw something really similar to this model. **Happen** is what happens: the paradigm, the essence of a sofa nowadays.

**Happen** originates with the aim of being normal, thus, it has been conceived to go beyond transient fads; its timeless shapes transcend this. **Rafa García** didn't try to reinvent anything, he just practiced good design - taking into account the proportions, materials, seams - and the ability to create dynamic compositions; always with the conviction that every detail is really important, however small.

The project eschews grand gestures and gimmicks, but, instead, uses neutral forms and simplicity as the base for the collection and its development. It is this pretence of normality what differentiates the product. Details are studied without artifice. Thus, Rafa adheres to the philosophy that promoted Naoto Fukasawa and Jasper Morrison through the exhibition *Super Normal, Sensations of the Ordinary*.

**Happen** uses a narrow L-shaped base to integrate all the elements. More than a puzzle, it is a large modular program, closer to the modular furniture system than to upholstery.

Faced with the premise of offering an extensive modularity with which to work and integrate into all kinds of spaces, the challenge was to find original parts to meet new needs, such as: add to the structure of the sofa a surface to support different objects; various types of arms; a double bottom module; terminal modules, and chaises longues of different formats.

It also allows us to create angles with a large number of pieces. Not to mention the accessories: poufs running loose and integrated into a composition or merging with a few upholstered tables to solve two applications in one. To all this modularity, we add an option: the duality of height of the back cushions - 74 and 84 centimetres.

The unseen details are even more important: the seat cushions are made from a special composition of polyurethane, on top of which is added a 6 cm. deep layer of memory foam.

*Mission accomplished!*

Si nous voulions représenter un canapé sur une feuille blanche, nous dessinerions certainement quelque chose de très proche à ce modèle, car de **Happen** surgit le paradoxe, l'essence de l'idée que l'on se fait de nos jours, d'un canapé.

**Happen** surgit dans le but de paraître normal, il a été conçu pour aller au-delà des tendances passagères. Formes intemporelles et transcendantes. **Rafa García**, n'a pas essayé de réinventer le canapé, mais de pratiquer un design simple, en tenant compte des proportions, des matériaux, des coutures et de la capacité de créer des compositions dynamiques; toujours convaincu que chaque détail, aussi petit soit il, est important.

Ce projet s'écarte des gestes exaltés et ne s'appuie pas sur une quelconque astuce, il fait appel aux formes neutres et à la simplicité, base de développement de la collection. C'est cette prétention de normalité qui différencie le produit. Des détails attentivement étudiés sans artifices. De cette façon, Rafa adhère à la philosophie promotionnée par Naoto Fukasawa et Jasper Morrison à travers de l'exposition *Super Normal. Sensations of the Ordinary*.

**Happen** propose une base amincie en forme de L dans laquelle on intègre différents éléments. Plus qu'un puzzle, il s'agit d'un ample programme modulaire, plus proche du système modulaire du meuble que celui d'un canapé.

Face à la prémisse d'offrir une modularité étendue, avec laquelle composer et adapter à tout type d'espaces, le but étant de trouver des pièces originales pour satisfaire des nouvelles nécessités, comme, par exemple : ajouter à la structure d'un canapé une surface servant d'appuis à différents objets, plusieurs accoudoirs, un module de double profondeur; modules terminaux et chaises longues de différentes formes.

Nous pouvons créer des angles avec un grand nombre de pièces. Sans oublier les pièces auxiliaires : poufs isolés ou intégrés dans une composition ou assemblés aux tables tapissées pour offrir deux utilisations en une. A toute cette modulation, nous devons ajouter une option non des moins importantes : la dualité des hauteurs des coussins de 74 et 84 centimètres.

Si les détails sont la clé du projet, ceux qui ne se voient pas le sont encore plus en offrant confort et continuité. La confection des coussins d'assise est réalisée à partir d'une composition spéciale de polyuréthane à laquelle nous avons ajouté une couche supérieure viscoélastique de 6cm d'épaisseur.

*Mission accomplie!*



















El módulo mesa puede incorporar un sobre de cristal fumé con arenado de formas circulares. De este modo ampliamos su funcionalidad.

We can add smoked glass with sandblasting circular shapes to the table module. In this way we expand its functionality.

Le module table peut être équipé en option d'un verre fumé (avec motifs sablés aux formes circulaires), afin d'optimiser sa fonctionnalité.















Happen 17

Mesa, table *Rock*  
Puf y taburete, pouf and stool, pouf et tabouret *Chat*  
Butaca, small armchair, petit fauteuil *Pío-pío*







Mesa, table *Rock*







Puf y taburete, pouf and stool, pouf et tabouret *Chat*











Happen

25

Mesa, table *Rock*  
Puf y taburete, pouf and stool, pouf et tabouret *Chat*  
Butaca, small armchair, petit fauteuil *Pío-pío*











# BOOMERANG CHILL

quím larrea & associates, 2009

Estética escandinava para una propuesta inspirada en un instrumento aborigen, el bumerán, como elemento vertebrador de todo el diseño.

**Boomerang chill** es la última e innovadora pieza de la colección Boomerang. **Quim Larrea** y su equipo completan, con gran éxito y satisfacción, la familia de asientos que ya en 2006 gestaron para Proyec, marca bajo la cual **Sancal** comercializa asientos – de cuidado diseño – adaptados a los requerimientos de usabilidad de la tercera edad. Como prueba de la atracción de su diseño, cabe mencionar que el sillón orejero fue finalista de los **premios Delta** y seleccionado para los **Designpreis** de Alemania.

Limpieza y sencillez formal, vetas de madera de fresno maciza, curvas cuidadosamente mecanizadas y tacto encerado, para evidenciar la nobleza y vocación naturalista de un diseño para siempre.

La sentada casi a ras de suelo da lugar a su apellido. **Boomerang chill** está comercializado bajo la marca **Sancal** como asiento para ambientes relajantes, *chill out*. En su nuevo formato y enfoque de mercado, propone tres piezas muy características: sillón relax, otoman y chaise longue.

Scandinavian aesthetic answer to a proposal inspired by an aboriginal implement - the boomerang – taken as the backbone of the whole design.

**Boomerang chill** is the latest innovative piece in the Boomerang collection. **Quim Larrea** and his team completed, with great success and satisfaction, the seat family which they had already designed in 2006 for Proyec: the brand under which **Sancal** sells seats - of meticulous design - tailored to the usability requirements of the elderly. As evidence of the attractiveness of its design, it is noteworthy that the armchair with headrest was a finalist for the **Delta** awards and selected for **Designpreis** of Germany.

Clean and formal simplicity, solid ash wood-grain –polished feel – and carefully machined curves, all showcase the noble and naturalistic crafting of a design classic.

The seat, almost at ground level, leads to the use of the adjective in **Boomerang chill**. It is marketed under the brand **Sancal** as a seat for relaxing atmospheres: *chill out*. In its new format and market focus, it offers three very distinctive versions: easy chair, ottoman and chaise longue.

Esthétique scandinave pour une proposition inspirée d'un instrument aborigène, le boomerang, la colonne vertébrale du produit.

**Boomerang Chill** est la dernière pièce innovatrice de la collection Boomerang. **Quim Larrea** et son équipe complètent avec grand succès et satisfaction, la famille des sièges qu'ils ont réalisé en 2006 pour Proyec, marque sous laquelle **Sancal** commercialise des sièges, d'un design consciencieux, adaptés aux exigences du troisième âge. Preuve de son succès grandissant, signalons que le fauteuil bergère fût finaliste des **prix Delta** et sélectionné pour les **Desingnprise** en Allemagne.

Pureté et simplicité formelle, beauté veinée du bois de frêne massif, rondeurs soigneusement mécanisées et un toucher ciré, qui relève la noblesse et vocation naturelle d'un design intemporel.

L'assise au ras du sol, nous inspire son nom. **Boomerang chill** est un fauteuil commercialisé par la marque **Sancal** destiné aux ambiances relaxantes, *chill out*. La nouvelle architecture, marque un changement de segment et propose 3 pièces : fauteuil relax, ottoman et chaise longue.

















# PÍO-PÍO

odosdesign, 2010



**P**ío-pío es un pollito que nos espera siempre con sus alas abiertas. En realidad, hablamos de una pequeña familia de asientos con personalidad propia, muy fresca y divertida. Las **Pío-Pío**, son como una mascota tierna, cariñosa y simpática que anhela ocupar un rincón especial en nuestro hogar.

En cualquiera de sus tres versiones (butaca, sillón y sillón plus), **Pío-Pío** se integrará perfectamente en cualquier espacio y, sin duda, lo dotará de agradables sensaciones.

El sillón es una fantástica opción para el punto y el macramé. La butaca, más pequeña y versátil, nos invita a la charla y a los juegos de mesa. El sillón plus, con su importante respaldo y su cómodo cojín, es perfecto para una tarde *de película*.

**P**ío-pío is a little bird always waiting for us with open wings. Actually, we're talking about a small-seat family with a unique personality: fresh and funny. **Pío-pío** is like a special pet, loving and friendly, intent on occupying a special corner in our homes.

In any of its three versions (small armchair, armchair and armchair plus), **Pío-pío** perfectly integrates in any space and there is no doubt that it will create a pleasant atmosphere.

The armchair is a fancy option for knitting and macramé. The small armchair, smaller and versatile, invites us to chat and play board games. The armchair plus, with its significant back and its comfortable cushion is perfect for spending a great evening sitting back: reading, watching movies or TV.

**P**ío-Pío est un poussin qui nous accueille avec ses ailes ouvertes. En réalité, nous parlons d'une petite famille de fauteuil avec une personnalité propre, fraîche et amusante. Les **Pío-Pío**, sont comme une tendre mascotte, affectueuse et sympathique qui souhaite occuper un coin très spécial dans notre foyer.

Dans chacune des trois versions (mini, fauteuil et fauteuil plus), **Pío-Pío** s'insère parfaitement dans n'importe quel espace et dégagera sans nul doute d'agréables sensations.

Le fauteuil est une fantastique option pour le tricot et le macramé. Le petit fauteuil, est universel, il invite à la conversation et aux jeux de société. Le fauteuil plus, avec son imposant dossier et son coussin confortable est parfait pour une après midi de cinéma.











Pío-Pío 44

Mesa, table *Rock*  
Sofá, sofa, canapé *Happen*









# ACE

**a-cero, 2010**

**P**isamos fuerte, seguros, con pies de acero... porque no queremos dejar de sorprender. Otro año más seguimos aportando elegancia con un diseño a gran escala, la que nos marcamos con **Ace**, un punto directo.

**Ace** es diseño, calidad y funcionalidad. Su versatilidad le permite estar presente en cualquier lugar, desde el más básico al más sofisticado, sin renunciar a un estilo limpio, sencillo y distinguido.

Arquitectónico y escultural, sus líneas nos revelan la filosofía de trabajo de **A-cero**: volumen, amplitud, espacios abiertos, elegancia, luminosidad, seguridad, confianza, libertad...

Sus acogedores volúmenes estimulan y crean una atmósfera confortable. Lo más destacado de **Ace** son sus amplios y sinuosos brazos, una sensual y delicada curva que perfecciona el producto y deslumbrará por su diseño y adaptabilidad, sin renunciar a su fuerte carácter.

Con **Ace**, el estudio de arquitectura de **Joaquín Torres** ha conseguido dar forma a un nuevo lenguaje, un nuevo tipo de expresión no verbal a través del cual transmitimos que sabemos lo que te gusta.

**W**e stand strongly, firmly, on feet of silver... because we want to continue surprising you. One more year and we bring elegance with design on a large scale: the one we mark with **Ace**, a direct hit.

**Ace** is the epitome of design: quality and functionality. This versatility allows it to sit easily in any place, from the more basic to the most sophisticated, without renouncing clean style – casual yet distinguished.

Architectural and sculptural, its lines reveal **A-cero's** working philosophy: volume, ampleness, open spaces, elegance, lightness, safety, trust, freedom...

The cosy volumes stimulate and create a comfortable atmosphere. We highlight **Ace's** large and sinuous arms, a sensual and delicate curve that enhances the product and that will dazzle thanks to its design and adaptability - without relinquishing its strong character.

With **Ace**, the architectural studio of **Joaquín Torres** has managed to shape a new language: a type of non-verbal language through which we communicate.

**N**ous avançons d'un pas solide, confiants, avec des pieds d'acier... parce que nous voulons obstinément surprendre. Cette année encore, nous apportons de l'élégance, un design à grande échelle, un regard déterminant, caractéristiques choisies pour **Ace**.

**Ace** c'est design, qualité et fonctionnalité. Sa versatilité lui permet d'être présent dans n'importe quel espace, du plus basique au plus sophistiqué, sans renoncer à un style pur, simple et distingué.

Architectonique et sculptural, ses lignes nous révèlent la philosophie du travail de **A-cero**: volumes, envergure, espaces ouverts, élégance, luminosité, sécurité, confiance, liberté...

Ses dimensions accueillantes stimulent et créent une atmosphère confortable. Les accoudoirs de **Ace** sont remarquables, amples et sinueux, leur arrondi délicat et sensuel donne une perfection au produit qui séduit par son design et capacité d'intégration, sans renoncer à affirmer son caractère.

Avec **Ace**, le bureau d'architecture de **Joaquín Torres** réussit à donner forme à un nouveau langage, un nouveau type d'expression non verbal à travers duquel nous interprétons ce que tu apprécies.





















# CHAT

nadadora, 2010

*Chat es compartir, interactuar, hablar...  
Chat es público y es privado.  
Chat es redondo, sugerente, bicolor...*

*Chat is sharing, interacting, talking...  
Chat is public and private.  
Chat is round, suggestive, bicolour...*

*Chat c'est partager, interagir, parler...  
Chat c'est public et c'est privé.  
Chat c'est rond, suggestif, bicolore...*

**C**hat es un espacio de reunión, un lugar como punto de encuentro, un símbolo de la interacción entre personas. **Chat** es una colección de pufs y taburetes concebida como complemento de ambientes hogareños, que, en espacios colectivos, facilita la creación de lugares comunes. Se trata del tipo de mobiliario más apropiado para crear pequeñas privacidades en entornos públicos.

De formas amables y sencilla geometría, **Chat** se fusiona con el resto de elementos arquitectónicos que definen cada espacio. La combinación bicolor de los tejidos facilita su adaptabilidad a diferentes entornos. Con este proyecto, el estudio **Nadadora** multiplica las posibilidades de crear diferentes espacios sensoriales, alegres, coloristas y serenos. **Chat** ofrece emoción al mueble tapizado.

**C**hat: a collective space, a place as a meeting point, a symbol of interaction among people. **Chat** is a collection of poufs and stools conceived as a complement for home-like environments, that enables the creation of common places in collective spaces. It is the most appropriate piece of furniture to create intimate areas in public environments.

**Chat**, with its pleasant and easy geometry, merges with the rest of the architectural elements defining each space. The bicolour fabric combination facilitates adaptability to different ambiances. With this project, the **Nadadora** studio multiplies the options for different sensory, cheerful, colourist and serene spaces. **Chat** brings emotion to upholstered furniture.

**C**hat est un espace de réunion, un lieu de rencontre, un symbole de l'interaction entre personnes. **Chat** est une collection de poufs et tabourets conçus comme compléments d'ambiances intimes, qui intégrés dans les espaces collectifs deviennent des lieux communs. Il s'agit d'un type de mobilier destiné à créer des ambiances privées dans des environnements publics.

Des formes sages, de géométrie simple, **Chat** fusionne avec les éléments architectoniques qui définissent chaque espace. La combinaison bicolore des tissus facilite son adaptation aux différentes ambiances. Avec ce projet, le studio d'architecture **Nadadora** multiplie les possibilités de créer différents espaces sensoriels, heureux, colorés et sereins. **Chat** donne de l'émotion au meuble rembourré.















# ROCK

rafa garcía, 2010

Técnicamente, el rock es un ritmo de blues acelerado. En esta ocasión, sin embargo, **Rock** es una pequeña familia de mesas inspiradas en la profusión, exuberancia y optimismo de los años 50'. Un proyecto expresivo y sensual influenciado por las formas orgánicas y biomorfas que popularizaron los precursores del diseño industrial.

Las mesitas **Rock**, al igual que el estilo musical del que toman su nombre, se caracterizan por tener un carácter contemporáneo, así como por hacer posible la fusión de diversos estilos, en este caso visuales en lugar de sonoros. Roble, espejo y cristal fumé son las notas de una partitura que permite crear una melodía personalizada. Además de jugar con sus curvas, volúmenes y materiales, sus diferentes alturas y la mesita elevable incrementan la versatilidad del conjunto.

Technically, rock is an accelerated blues rhythm. In this instance, however, **Rock** is a small family of tables inspired by the abundance, exuberance and optimism of the '50s -an expressive and sensual project influenced by organic and biomorphic forms which popularized the pioneers of industrial design.

The **Rock** tables, like the musical style from which the name is taken, are characterized by a contemporary feel, and by the fusion of different styles - in this case visual rather than sonorous. Oak, mirror and smoked glass are the notes of a score that can create a personalized melody. Besides playing with the curves, volumes and materials, the different heights and lifting table increase the versatility of the set.

Techniquement, le rock est un rythme accéléré du blues. Par contre, dans ce cas précis, **Rock** est une petite famille de tables inspirées de l'exubérance, de la profusion et optimisme des années 50'. Un projet expressif et sensuel influencé par les formes organiques et biomorphes qui ont popularisé les précurseurs du design industriel.

Les tables **Rock**, ainsi que le style musical duquel elles puisent leur nom, se caractérisent par un reflet contemporain, qui fait fusionner plusieurs styles, dans ce cas-ci visuels et non sonores. Chêne, miroir et verre fumé sont les notes d'une partition qui permettent de créer une mélodie personnalisée. En plus de jouer avec les formes arrondies, volumes et matériaux, ses différentes hauteurs et table éleveur ajoutent de la versatilité à l'ensemble.





















# TEA

estudiahac jmferrero, 2010



**T**ea es la consecuencia de reclamar a un placer estético que se percibe por la vista y el tacto; de una intensa búsqueda para despertar emociones en el usuario. Para ello Sancal ha contado con el **estudihac** de **José Manuel Ferrero**, quien ha proyectado una colección de asientos inspirada en el momento del té, en los antiguos juegos de tazas de fina porcelana.

Con puntualidad y disciplina anglosajona, **estudihac** propone para esta temporada combinar texturas y materiales al más puro estilo british. Delicada confección prêt-à-porte para unos acolchados de terciopelo mate en colores sobrios y treviras estampadas en cuadrillos que nos recuerdan al tradicional tweed. Una selección realizada ad hoc, a partir de los tejidos Star y Pro2 de la marca danesa **Kvadrat**, en la que imperan los tonos beige, gris, marrón, granate, verde y caldera.

El acolchado hexagonal y las opciones bicolor son los elementos clave este clásico revisado, actual y desenfado, pero siempre elegante y distinguido. Sin duda, una de las propuestas más especiales y novedosas del mercado.

La colección está formada por butacas, sillones y sofás. Próximamente incorporaremos nuevas y sorprendentes piezas.

**T**ea is the result of reclaiming an aesthetic pleasure perceived by sight and touch, an intense search to arouse emotions in the user. In order to do this, Sancal has relied on the **estudihac** of **Jose Manuel Ferrero**, who has designed a seating collection inspired by teatime – by the old, delicate china tea-set.

With exquisite timing and Anglo-Saxon discipline, **estudihac** combines textures and materials in the purest British style for this season. We offer a delicate prêt-à-porte covering of quilted matt velvet upholstery in sober colours and patterned squares – in Trevira - that is reminiscent of traditional tweed. It is an ad hoc selection made from Star upholsteries and Pro2 from the Danish brand **Kvadrat**, where beiges, greys, browns, maroons, greens and copper colours prevail.

The hexagonal-quilted and the bicolour options are key elements for this revised classic, contemporary and casual but always elegant and distinguished. It is undoubtedly one of the most special and innovative ranges on the market.

The collection consists of small armchairs, sofas and armchairs. New and exciting pieces will be added in the near future.

**T**ea est la conséquence d'une demande constante de plaisir esthétique qui se perçoit par la vue et le toucher; et d'une recherche intense afin de réveiller les émotions des utilisateurs. Pour cela Sancal a pu compter avec **estudihac** de **Jose Manuel Ferrero**, qui a proposé une collection de sièges inspirés de l'ambiance conviviale à l'heure du té, servi dans les tasses de fine porcelaine ancienne.

Avec la ponctualité et discipline Anglo-saxonne, **estudihac** propose cette saison de combiner les textures et matériaux dans le plus pur style british. La confection raffinée d'un matelassage de velours mat, style prêt à porter, aux couleurs sobres et treviras en carreaux imprimés nous rappellent le tweed traditionnel. Une sélection, ad hoc, réalisée à partir des tissus Star et Pro2 de la marque danoise **Kvadrat**, dans laquelle dominent les tons beige, gris, marron, bordeaux, verts et chaudron.

Le matelassé hexagonal et les options bicolores sont les éléments clés de ce classique revisité, actuel et nonchalant, en même temps élégant et distingué. Sans doute, une des propositions les plus spéciales et novatrices du marché.

La collection est composée de plusieurs fauteuils et canapés. Prochainement nous ajouterons d'autres pièces innovantes et surprenantes.



































# MANDARINAS

**elena castaño-lópez, 2010**

**E**l proyecto **Mandarinas** toma prestadas técnicas de costura propias de la corsetería para dar lugar a una detallista colección de cojines de formas redondeadas.

**Mandarinas** es la primera colección de cojines de autor, autora en este caso, que Sancal lanza al mercado.

**T**he **Mandarins** project borrows sewing techniques from the lingerie trade to lead to a detailed collection of rounded cushions.

**Mandarins** is the first named, stand-alone, range of designer cushions collection which Sancal has launched.

**L**e projet **Mandarinas** utilise des techniques très habiles de haute couture, propres au secteur de la corsetterie pour donner corps à une collection exclusive de coussins aux formes arrondies.

**Mandarinas** est la première collection de coussins d'auteur, que Sancal lance en exclusivité.





# technical index

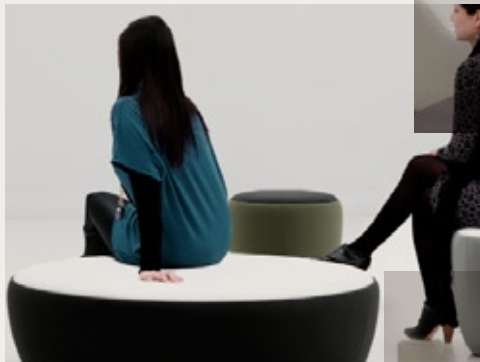
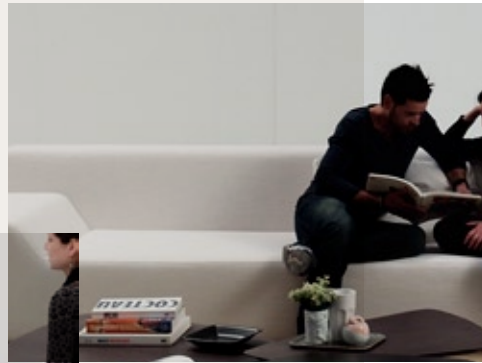

### Happen Pag. 06-07

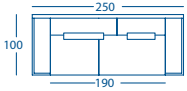

| UNI. | MOD.   | DESCRIPCIÓN / DESCRIPTION / DESCRIPTION  | REF.         | TELAS FABRIC TISSUS | SERIES | PUNTOS POINTS POINTS |
|------|--------|--|--------------|---------------------|--------|----------------------|
| 1    | HAPPEN | SOFA 250 BRAZO ANCHO ALTO 74<br>SOFA 250 WIDE ARM HIGH 74<br>CANAPE 250 BRAS LARGE HAUT 74 | 256.11.Z2H.1 | 1613                | A      | 1153                 |

### Happen Pag. 08

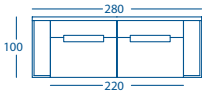

| UNI. | MOD.   | DESCRIPCIÓN / DESCRIPTION / DESCRIPTION  | REF.         | TELAS FABRIC TISSUS | SERIES | PUNTOS POINTS POINTS |
|------|--------|--|--------------|---------------------|--------|----------------------|
| 1    | HAPPEN | SOFA 280 BRAZO ANCHO ALTO 74<br>SOFA 280 WIDE ARM HIGH 74<br>CANAPE 280 BRAS LARGE HAUT 74 | 256.11.Z5H.1 | 6046                | ESP    | 1367                 |

### Happen Pag. 09

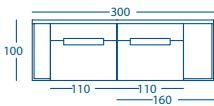

| UNI. | MOD.   | DESCRIPCIÓN / DESCRIPTION / DESCRIPTION   | REF.           | TELAS FABRIC TISSUS | SERIES | PUNTOS POINTS POINTS |
|------|--------|---|----------------|---------------------|--------|----------------------|
| 1    | HAPPEN | BRAZO ANCHO IZDO<br>WIDE LEFT ARM<br>BRAS LARGE GAUCHE  | 256.131.I      | 6045                | ESP    | 150                  |
| 1    | HAPPEN | MODULO 110 ALTO 74<br>MODULE 110 HIGH 74<br>MODULE 110 HAUT 74  | 256.121.MH     | 6045                | ESP    | 574                  |
| 1    | HAPPEN | MODULO 160 BRAZO BAJO DCHO ALTO 74<br>MODULE 160 LOW RIGHT ARM HIGH 74<br>MODULE 160 BRAS BAS DROIT HAUT 74 | 256.122.SH.J.D | 6045                | ESP    | 749                  |
| 2    | HAPPEN | ALMOHADA RIÑONERA 70X29<br>LUMBAR CUSHION 70X29<br>COUSSIN CALE REIN 70X29                                  | 256.27.HC      | 6034                | ESP    | -                    |

### Happen Pag. 10

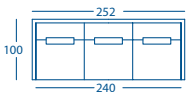

| UNI. | MOD.   | DESCRIPCIÓN / DESCRIPTION / DESCRIPTION  | REF.         | TELAS FABRIC TISSUS | SERIES | PUNTOS POINTS POINTS |
|------|--------|--|--------------|---------------------|--------|----------------------|
| 1    | HAPPEN | SOFA 252 BRAZO ESTRECHO ALTO 74<br>SOFA 252 NARROW ARM HIGH 74<br>CANAPE 252 BRAS ETROIT HAUT 74 | 256.11.Z2H.2 | 1604                | A      | 1265                 |

### Happen Pag. 11-12

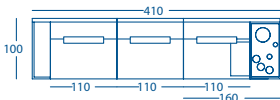

| UNI. | MOD.   | DESCRIPCIÓN / DESCRIPTION / DESCRIPTION   | REF.            | TELAS FABRIC TISSUS | SERIES | PUNTOS POINTS POINTS |
|------|--------|---|-----------------|---------------------|--------|----------------------|
| 1    | HAPPEN | BRAZO ANCHO IZDO<br>WIDE LEFT ARM<br>BRAS LARGE GAUCHE  | 256.131.I       | 6045                | ESP    | 150                  |
| 2    | HAPPEN | MODULO 110 ALTO 84<br>MODULE 110 HIGH 84<br>MODULE 110 HAUT 84  | 256.121.MJ      | 6045                | ESP    | 1190                 |
| 1    | HAPPEN | MODULO MESA 160 C/ALM BR DCHO ALTO 74<br>MODULE TABLE 160 WITH RIGHT ARMREST HIGH 74<br>MODULE TABLE 160 AVEC REPOSE BRAS DROIT HAUT 74 | 256.121.SH.KH.D | 6045                | ESP    | 746                  |
| 1    | HAPPEN | TAPA 210 CR-FUMÉE 45X88<br>GLASS TOP 45X88<br>PLATEAU VERRE 45X88   | 256.32.EJ.L     | 210                 | -      | 72                   |
| 2    | HAPPEN | ALMOHADA RIÑONERA 70X29<br>LUMBAR CUSHION 70X29<br>COUSSIN CALE REIN 70X29  | 256.27.HC       | 6034                | ESP    | -                    |

### Happen Pag. 13

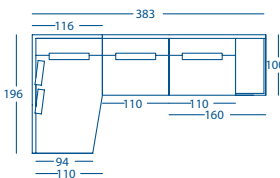

| UNI. | MOD.   | DESCRIPCIÓN / DESCRIPTION / DESCRIPTION  | REF.            | TELAS FABRIC TISSUS | SERIES | PUNTOS POINTS POINTS |
|------|--------|--|-----------------|---------------------|--------|----------------------|
| 1    | HAPPEN | CHAISE LONGUE 116X196 BRAZO ESTRECHO IZDO ALTO 74<br>CHAISE LONGUE 116X196 NARROW LEFT ARM HIGH 74<br>CHAISE LONGUE 116X196 BRAS ETROIT GAUCHE HAUT 74 | 256.142.MVH.2.I | 6045                | ESP    | 934                  |
| 1    | HAPPEN | MODULO 110 ALTO 74<br>MODULE 110 HIGH 74<br>MODULE 110 HAUT 74   | 256.121.MH      | 6045                | ESP    | 574                  |
| 1    | HAPPEN | MODULO 160 BRAZO BAJO DCHO ALTO 74<br>MODULE 160 LOW RIGHT ARM HIGH 74<br>MODULE 160 BRAS BAS DROIT HAUT 74  | 256.122.SH.J.D  | 6045                | ESP    | 749                  |



### Happen Pag. 14-15

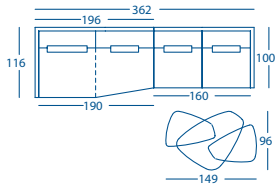

| UNL. | MOD.   | DESCRIPCIÓN / DESCRIPTION / DESCRIPTION  | REF.            | TELAS / FABRIC / TISSUS | SERIES | PUNTOS / POINTS / POINTS |
|------|--------|--|-----------------|-------------------------|--------|--------------------------|
| 1    | HAPPEN | MOD. DOBLE FONDO 196 BRAZO ESTRECHO IZDO ALTO 74<br>MOD. 196 DOUBLE DEPTH NARROW LEFT ARM HIGH 74<br>MOD. DOUBLE PROFONDEUR 196 BRAS ETROIT GAUCHE HAUT 74 | 256.122.VH.ZQ.I | 6045                    | ESP    | 1022                     |
| 1    | HAPPEN | MODULO 160 ALTO 74<br>MODULE 160 HIGH 74<br>MODULE 160 HAUT 74   | 256.121.SH      | 6045                    | ESP    | 813                      |
| 1    | HAPPEN | BRAZO ESTRECHO DCHO<br>NARROW RIGHT ARM<br>BRAS ETROIT DROIT   | 256.132.D       | 6045                    | ESP    | 72                       |
| 1    | ROCK   | MESA 81x58x35<br>TABLE 81x58x35<br>TABLE 81x58x35  | 265.71.JFD      | 301                     | -      | 184                      |
| 1    | ROCK   | MESA 81x58x35<br>TABLE 81x58x35<br>TABLE 81x58x35  | 265.71.JFD      | 030                     | -      | 184                      |
| 1    | ROCK   | MESA 108x81x31<br>TABLE 108x81x31<br>TABLE 108x81x31   | 265.71.LJD      | 004                     | -      | 243                      |

### Happen Pag. 16-17

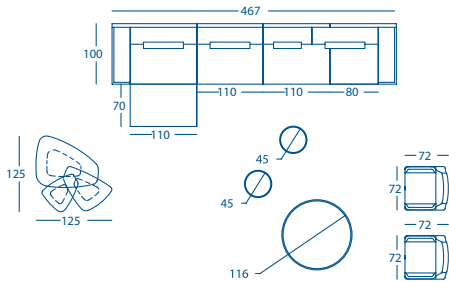

| UNL. | MOD.    | DESCRIPCIÓN / DESCRIPTION / DESCRIPTION                        | REF.       | TELAS / FABRIC / TISSUS | SERIES   | PUNTOS / POINTS / POINTS |
|------|---------|--|------------|-------------------------|----------|--------------------------|
| 1    | HAPPEN  | BRAZO ANCHO IZDO<br>WIDE LEFT ARM<br>BRAS LARGE GAUCHE         | 256.131.I  | 6045                    | ESP      | 150                      |
| 3    | HAPPEN  | MODULO 110 ALTO 74<br>MODULE 110 HIGH 74<br>MODULE 110 HAUT 74 | 256.121.MH | 6045                    | ESP      | 574                      |
| 1    | HAPPEN  | MODULO 80 ALTO 74<br>MODULE 80 HIGH 74<br>MODULE 80 HAUT 74    | 256.121.JH | 6045                    | ESP      | 497                      |
| 1    | HAPPEN  | BRAZO ANCHO DCHO<br>WIDE RIGHT ARM<br>BRAS LARGE DROIT         | 256.131.D  | 6045                    | ESP      | 150                      |
| 1    | PIO-PIO | BUTACA<br>SMALL ARMCHAIR<br>PETIT FAUTEUIL                     | 255.51     | 3862                    | C        | 280                      |
| 1    | PIO-PIO | BUTACA<br>SMALL ARMCHAIR<br>PETIT FAUTEUIL                     | 255.51     | 3867                    | C        | 280                      |
| 1    | CHAT    | TABURETE D45X44<br>STOOL D45X44<br>TABOURET D45X44             | 263.151.EE | 3855<br>6080            | C<br>ESP | 133                      |
| 1    | CHAT    | TABURETE D45X44<br>STOOL D45X44<br>TABOURET D45X44             | 263.151.EE | 6074<br>3855            | ESP<br>C | 133                      |
| 1    | CHAT    | PUF D116X36<br>POUF D116X36<br>POUF D116X36                    | 263.151.MD | 3855<br>3857            | C        | 257                      |
| 1    | ROCK    | MESA 62X48X39<br>TABLE 62X48X39<br>TABLE 62X48X39              | 265.71.GED | 301                     | -        | 152                      |
| 1    | ROCK    | MESA 81x58x35<br>TABLE 81x58x35<br>TABLE 81x58x35              | 265.71.JFD | 301                     | -        | 184                      |
| 1    | ROCK    | MESA 108x81x31<br>TABLE 108x81x31<br>TABLE 108x81x31           | 265.71.LJD | 301                     | -        | 243                      |

### Happen Pag. 18-19

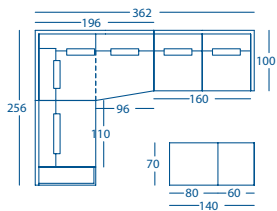

| UNL. | MOD.   | DESCRIPCIÓN / DESCRIPTION / DESCRIPTION  | REF.          | TELAS / FABRIC / TISSUS | SERIES | PUNTOS / POINTS / POINTS |
|------|--------|--|---------------|-------------------------|--------|--------------------------|
| 1    | HAPPEN | BRAZO ANCHO IZDO<br>WIDE LEFT ARM<br>BRAS LARGE GAUCHE   | 256.131.I     | 6045                    | ESP    | 150                      |
| 1    | HAPPEN | MODULO 110 ALTO 74<br>MODULE 110 HIGH 74<br>MODULE 110 HAUT 74   | 256.121.MH    | 6045                    | ESP    | 574                      |
| 1    | HAPPEN | ANGULO DOBLE FONDO 196 IZDO ALTO 74<br>LEFT STRAIGHT CORNER 196 DOUBLE DEPTH HIGH 74<br>ANGLE DOUBLE PROFONDEUR 196 GAUCHE HAUT 74 | 256.16.VH.Q.I | 6045                    | ESP    | 1108                     |
| 1    | HAPPEN | MODULO 160 ALTO 74<br>MODULE 160 HIGH 74<br>MODULE 160 HAUT 74   | 256.121.SH    | 6045                    | ESP    | 813                      |
| 1    | HAPPEN | BRAZO ESTRECHO DCHO<br>NARROW RIGHT ARM<br>BRAS ETROIT DROIT   | 256.132.D     | 6045                    | ESP    | 72                       |
| 1    | HAPPEN | PUF MESA 140X70<br>POUF TABLE 140X70<br>POUF TABLE 140X70  | 256.151.QH.K  | 6045                    | ESP    | 321                      |

### Happen Pag. 20-21

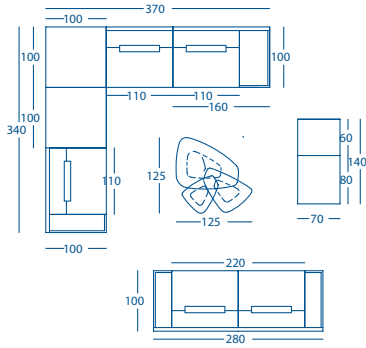

| UNL. | MOD.   | DESCRIPCIÓN / DESCRIPTION / DESCRIPTION   | REF.           | TELAS FABRIC TISSUS | SERIES | PUNTOS POINTS POINTS |
|------|--------|---|----------------|---------------------|--------|----------------------|
| 1    | HAPPEN | BRAZO ANCHO IZDO<br>WIDE LEFT ARM<br>BRAS LARGE GAUCHE  | 256.131.I      | 6045                | ESP    | 150                  |
| 1    | HAPPEN | MODULO 110 ALTO 74<br>MODULE 110 HIGH 74<br>MODULE 110 HAUT 74  | 256.121.MH     | 6045                | ESP    | 574                  |
| 2    | HAPPEN | PUF 100X100<br>POUF 100X100<br>POUF 100X100   | 256.151.LL     | 6045                | ESP    | 351                  |
| 1    | HAPPEN | MODULO 110 ALTO 74<br>MODULE 110 HIGH 74<br>MODULE 110 HAUT 74  | 256.121.MH     | 6045                | ESP    | 574                  |
| 1    | HAPPEN | MODULO 160 BRAZO BAJO DCHO ALTO 74<br>MODULE 160 LOW RIGHT ARM HIGH 74<br>MODULE 160 BRAS BAS DROIT HAUT 74 | 256.122.SH.J.D | 6045                | ESP    | 749                  |
| 1    | HAPPEN | PUF MESA 140X70<br>POUF TABLE 140X70<br>POUF TABLE 140X70   | 256.151.QH.K   | 6045                | ESP    | 321                  |
| 1    | HAPPEN | SOFA 280 BRAZO ANCHO ALTO 74<br>SOFA 280 WIDE ARM HIGH 74<br>CANAPE 280 BRAS LARGE HAUT 74                  | 256.11.Z5H.1   | 6046                | ESP    | 1367                 |
| 1    | ROCK   | MESA 62X48X39<br>TABLE 62X48X39<br>TABLE 62X48X39   | 265.71.GED     | 301                 | -      | 184                  |
| 1    | ROCK   | MESA 81x58x35<br>TABLE 81x58x35<br>TABLE 81x58x35   | 265.71.JFD     | 030                 | -      | 184                  |
| 1    | ROCK   | MESA 108x81x31<br>TABLE 108x81x31<br>TABLE 108x81x31  | 265.71.LJD     | 004                 | -      | 243                  |

### Happen Pag. 22-23

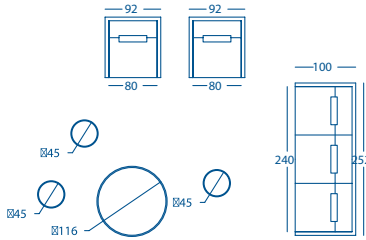

| UNL. | MOD.   | DESCRIPCIÓN / DESCRIPTION / DESCRIPTION   | REF.         | TELAS FABRIC TISSUS | SERIES | PUNTOS POINTS POINTS |
|------|--------|---|--------------|---------------------|--------|----------------------|
| 1    | HAPPEN | SOFA 252 BRAZO ESTRECHO ALTO 74<br>SOFA 252 NARROW ARM HIGH 74<br>CANAPE 252 BRAS ETROIT HAUT 74      | 256.11.Z2H.2 | 1604                | A      | 1265                 |
| 2    | HAPPEN | SILLON 92 BRAZO ESTRECHO ALTO 74<br>ARMCHAIR 92 NARROW ARM HIGH 74<br>FAUTEUIL 92 BRAS ETROIT HAUT 74 | 256.11.KH.2  | 1604                | A      | 1156                 |
| 2    | CHAT   | TABURETE D45X44<br>STOOL D45X44<br>TABOURET D45X44  | 263.151.EE   | 3858<br>3856        | C      | 230                  |
| 1    | CHAT   | TABURETE D45X44<br>STOOL D45X44<br>TABOURET D45X44  | 263.151.EE   | 6076<br>6080        | ESP    | 141                  |
| 1    | CHAT   | PUF D116X36<br>POUF D116X36<br>POUF D116X36   | 263.151.MD   | 3855<br>3857        | C      | 257                  |

### Happen Pag. 24-26

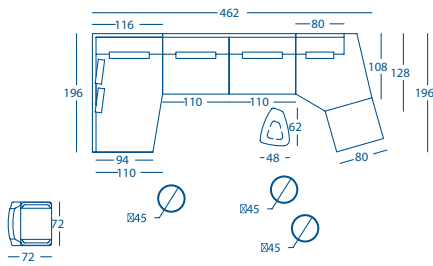

| UNL. | MOD.    | DESCRIPCIÓN / DESCRIPTION / DESCRIPTION  | REF.            | TELAS FABRIC TISSUS | SERIES | PUNTOS POINTS POINTS |
|------|---------|--|-----------------|---------------------|--------|----------------------|
| 1    | HAPPEN  | CHAISE LONGUE 116X196 BRAZO ESTRECHO IZDO ALTO 74<br>CHAISE LONGUE 116X196 NARROW LEFT ARM HIGH 74<br>CHAISE LONGUE 116X196 BRAS ETROIT GAUCHE HAUT 74 | 256.142.MVH.2.I | 6045                | ESP    | 934                  |
| 2    | HAPPEN  | MODULO 110 ALTO 74<br>MODULE 110 HIGH 74<br>MODULE 110 HAUT 74   | 256.121.MH      | 6045                | ESP    | 1148                 |
| 1    | HAPPEN  | MODULO TERMINAL 126 DCHO ALTO 74<br>RIGHT TERMINAL MODULE 126 HIGH 74<br>MODULE TERMINAL 126 DROIT HAUT 74   | 256.17.NH.D     | 6045                | ESP    | 707                  |
| 1    | HAPPEN  | PUF 80X70<br>POUF 80X70<br>POUF 80X70  | 256.151.JH      | 6045                | ESP    | 261                  |
| 2    | HAPPEN  | ALMOHADA RIÑONERA 70X29<br>LUMBAR CUSHION 70X29<br>COUSSIN CALE REIN 70X29   | 256.27.HC       | 6034                | ESP    | -                    |
| 2    | HAPPEN  | ALMOHADA RIÑONERA 50X29<br>LUMBAR CUSHION 50X29<br>COUSSIN CALE REIN 50X29   | 256.27.FC       | 6034                | ESP    | -                    |
| 1    | CHAT    | TABURETE D45X44<br>STOOL D45X44<br>TABOURET D45X44   | 263.151.EE      | 6076<br>6080        | ESP    | 141                  |
| 1    | CHAT    | TABURETE D45X44<br>STOOL D45X44<br>TABOURET D45X44   | 263.151.EE      | 6078<br>6076        | ESP    | 141                  |
| 1    | CHAT    | TABURETE D45X44<br>STOOL D45X44<br>TABOURET D45X44   | 263.151.EE      | 6081<br>6074        | ESP    | 141                  |
| 1    | PIO-PIO | BUTACA<br>SMALL ARMCHAIR<br>PETIT FAUTEUIL   | 255.51          | 6055                | ESP    | 329                  |
| 1    | ROCK    | MESA ELEVABLE 62X48X39/60<br>LIFTING TABLE 62X48X39/60<br>TABLE ELEVATEUR 62X48X39/60  | 265.76.GED      | 030                 | -      | 227                  |

## Happen Pag. 27

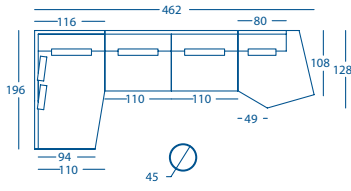

| UNI. | MOD.   | DESCRIPCIÓN / DESCRIPTION / DESCRIPTION  | REF.            | TELAS FABRIC TISSUS | SERIES | PUNTOS POINTS POINTS |
|------|--------|--|-----------------|---------------------|--------|----------------------|
| 1    | HAPPEN | CHAISE LONGUE 116X196 BRAZO ESTRECHO IZDO ALTO 84<br>CHAISE LONGUE 116X196 NARROW LEFT ARM HIGH 84<br>CHAISE LONGUE 116X196 BRAS ETROIT GAUCHE HAUT 84 | 256.142.MVJ.2.I | 6045                | ESP    | 946                  |
| 1    | HAPPEN | MODULO 110 ALTO 84<br>MODULE 110 HIGH 84<br>MODULE 110 HAUT 84   | 256.121.MJ      | 6045                | ESP    | 595                  |
| 1    | HAPPEN | MODULO 110 ALTO 74<br>MODULE 110 HIGH 74<br>MODULE 110 HAUT 74   | 256.121.MH      | 6045                | ESP    | 574                  |
| 1    | HAPPEN | MODULO TERMINAL 126 DCHO ALTO 74<br>RIGHT TERMINAL MODULE 126 HIGH 74<br>MODULE TERMINAL 126 DROIT HAUT 74   | 256.17.NH.D     | 6045                | ESP    | 707                  |
| 2    | HAPPEN | ALMOHADA RIÑONERA 70X29<br>LUMBAR CUSHION 70X29<br>COUSSIN CALE REIN 70X29   | 256.27.HC       | 6034                | ESP    | -                    |
| 2    | HAPPEN | ALMOHADA RIÑONERA 50X29<br>LUMBAR CUSHION 50X29<br>COUSSIN CALE REIN 50X29   | 256.27.FC       | 6034                | ESP    | -                    |
| 1    | CHAT   | TABURETE D45X44<br>STOOL D45X44<br>TABOURET D45X44   | 263.151.EE      | 6076<br>6080        | ESP    | 141                  |

## Happen Pag. 28-29

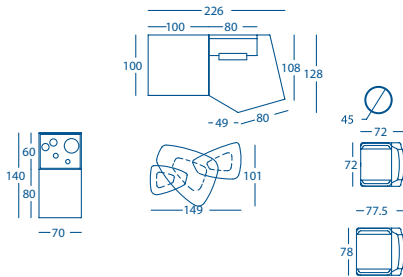

| UNI. | MOD.    | DESCRIPCIÓN / DESCRIPTION / DESCRIPTION  | REF.         | TELAS FABRIC TISSUS | SERIES | PUNTOS POINTS POINTS |
|------|---------|--|--------------|---------------------|--------|----------------------|
| 1    | HAPPEN  | PUF 100X100<br>POUF 100X100<br>POUF 100X100  | 256.151.LL   | 6045                | ESP    | 351                  |
| 1    | HAPPEN  | MODULO TERMINAL 126 DCHO ALTO 74<br>RIGHT TERMINAL MODULE 126 HIGH 74<br>MODULE TERMINAL 126 DROIT HAUT 74 | 256.17.NH.D  | 6045                | ESP    | 707                  |
| 1    | HAPPEN  | PUF MESA 140X70<br>POUF TABLE 140X70<br>POUF TABLE 140X70  | 256.151.QH.K | 6045                | ESP    | 321                  |
| 1    | HAPPEN  | TAPA 210 CR-FUMÉE 56X66<br>GLASS TOP 56X66<br>PLATEAU VERRE 56X66  | 256.32.FG.L  | 210                 | -      | 72                   |
| 1    | PIO-PIO | SILLON<br>ARMCHAIR<br>FAUTEUIL   | 255.61.J     | 6076                | ESP    | 364                  |
| 1    | PIO-PIO | SILLON PLUS<br>ARMCHAIR PLUS<br>FAUTEUIL PLUS  | 255.61.K     | 6072                | ESP    | 417                  |
| 1    | PIO-PIO | ALMOHADA RIÑONERA CON BANDA<br>LUMBAR CUSHION WITH BAND<br>COUSSIN CALE REIN AVEC PLATE-BANDE              | 255.27       | 6071                | ESP    | -                    |
| 1    | CHAT    | TABURETE D45X44<br>STOOL D45X44<br>TABOURET D45X44   | 263.151.EE   | 3858<br>3856        | C      | 115                  |
| 1    | ROCK    | MESA 62X48X39<br>TABLE 62X48X39<br>TABLE 62X48X39  | 265.71.GED   | 002                 | -      | 152                  |
| 1    | ROCK    | MESA 81x58x35<br>TABLE 81x58x35<br>TABLE 81x58x35  | 265.71.JFD   | 030                 | -      | 184                  |
| 1    | ROCK    | MESA 108x81x31<br>TABLE 108x81x31<br>TABLE 108x81x31   | 265.71.LJD   | 002                 | -      | 243                  |

## Boomerang Chill Pag. 32-35

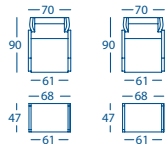

| UNI. | MOD.            | DESCRIPCIÓN / DESCRIPTION / DESCRIPTION  | REF.      | TELAS FABRIC TISSUS | SERIES | PUNTOS POINTS POINTS |
|------|-----------------|--|-----------|---------------------|--------|----------------------|
| 1    | BOOMERANG CHILL | BOOMERANG CHILL SILLON OREJERO<br>BOOMERANG CHILL ARMCHAIR WITH HEADREST<br>BOOMERANG CHILL FAUTEUIL | 003.631.H | 1610                | A      | 342                  |
| 1    | BOOMERANG CHILL | BOOMERANG CHILL PUF<br>BOOMERANG CHILL POUF<br>BOOMERANG CHILL POUF                                  | 003.151.H | 1610                | A      | 144                  |
| 1    | BOOMERANG CHILL | BOOMERANG CHILL SILLON OREJERO<br>BOOMERANG CHILL ARMCHAIR WITH HEADREST<br>BOOMERANG CHILL FAUTEUIL | 003.631.H | 1609                | A      | 342                  |
| 1    | BOOMERANG CHILL | BOOMERANG CHILL PUF<br>BOOMERANG CHILL POUF<br>BOOMERANG CHILL POUF                                  | 003.151.H | 1609                | A      | 144                  |

### Boomerang Chill Pag. 36

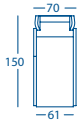

| UNL. | MOD.            | DESCRIPCIÓN / DESCRIPTION / DESCRIPTION  | REF.        | TELAS FABRIC TISSUS | SERIES | PUNTOS POINTS POINTS |
|------|-----------------|--|-------------|---------------------|--------|----------------------|
| 1    | BOOMERANG CHILL | BOOMERANG CHILL CHAISE BRAZO IZDO<br>BOOMERANG CHILL CHAISE LONGUE LEFT ARM<br>BOOMERANG CHILL CHAISE LONGUE BRAS GAUCHE | 003.142.H.I | 1617                | A      | 438                  |

### Boomerang Chill Pag. 37

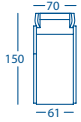

| UNL. | MOD.            | DESCRIPCIÓN / DESCRIPTION / DESCRIPTION  | REF.        | TELAS FABRIC TISSUS | SERIES | PUNTOS POINTS POINTS |
|------|-----------------|--|-------------|---------------------|--------|----------------------|
| 1    | BOOMERANG CHILL | BOOMERANG CHILL CHAISE BRAZO IZDO<br>BOOMERANG CHILL CHAISE LONGUE LEFT ARM<br>BOOMERANG CHILL CHAISE LONGUE BRAS GAUCHE | 003.142.H.I | 1609                | A      | 438                  |

### Pío-Pío Pag. 40

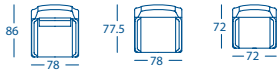

| UNL. | MOD.    | DESCRIPCIÓN / DESCRIPTION / DESCRIPTION       | REF.     | TELAS FABRIC TISSUS | SERIES | PUNTOS POINTS POINTS |
|------|---------|---|----------|---------------------|--------|----------------------|
| 1    | PIO-PIO | BUTACA<br>SMALL ARMCHAIR<br>PETIT FAUTEUIL    | 255.51   | 3862                | C      | 280                  |
| 1    | PIO-PIO | SILLON<br>ARMCHAIR<br>FAUTEUIL                | 255.61.J | 6072                | ESP    | 364                  |
| 1    | PIO-PIO | SILLON PLUS<br>ARMCHAIR PLUS<br>FAUTEUIL PLUS | 255.61.K | 3859                | C      | 348                  |

### Pío-Pío Pag. 42

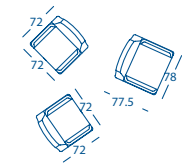

| UNL. | MOD.    | DESCRIPCIÓN / DESCRIPTION / DESCRIPTION    | REF.     | TELAS FABRIC TISSUS | SERIES | PUNTOS POINTS POINTS |
|------|---------|--|----------|---------------------|--------|----------------------|
| 1    | PIO-PIO | BUTACA<br>SMALL ARMCHAIR<br>PETIT FAUTEUIL | 255.51   | 3862                | C      | 280                  |
| 1    | PIO-PIO | BUTACA<br>SMALL ARMCHAIR<br>PETIT FAUTEUIL | 255.51   | 6072                | ESP    | 329                  |
| 1    | PIO-PIO | SILLON<br>ARMCHAIR<br>FAUTEUIL             | 255.61.J | 3859                | C      | 308                  |

### Pío-Pío Pag. 43

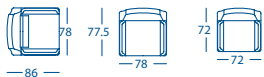

| UNL. | MOD.    | DESCRIPCIÓN / DESCRIPTION / DESCRIPTION   | REF.     | TELAS FABRIC TISSUS | SERIES | PUNTOS POINTS POINTS |
|------|---------|---|----------|---------------------|--------|----------------------|
| 1    | PIO-PIO | BUTACA<br>SMALL ARMCHAIR<br>PETIT FAUTEUIL  | 255.51   | 6055                | ESP    | 329                  |
| 1    | PIO-PIO | SILLON<br>ARMCHAIR<br>FAUTEUIL  | 255.61.J | 6072                | ESP    | 364                  |
| 1    | PIO-PIO | ALMOHADA RIÑONERA CON BANDA<br>LUMBAR CUSHION WITH BAND<br>COUSSIN CALE REIN AVEC PLATE-BANDE | 255.27   | 6072                | ESP    | 35                   |
| 1    | PIO-PIO | SILLON PLUS<br>ARMCHAIR PLUS<br>FAUTEUIL PLUS   | 255.61.K | 6071                | ESP    | 417                  |

### Pío-Pío Pag. 44

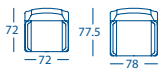

| UNL. | MOD.    | DESCRIPCIÓN / DESCRIPTION / DESCRIPTION   | REF.     | TELAS FABRIC TISSUS | SERIES | PUNTOS POINTS POINTS |
|------|---------|---|----------|---------------------|--------|----------------------|
| 1    | PIO-PIO | BUTACA<br>SMALL ARMCHAIR<br>PETIT FAUTEUIL  | 255.51   | 6072                | ESP    | 329                  |
| 1    | PIO-PIO | ALMOHADA RIÑONERA CON BANDA<br>LUMBAR CUSHION WITH BAND<br>COUSSIN CALE REIN AVEC PLATE-BANDE | 255.27   | 6072                | ESP    | 35                   |
| 1    | PIO-PIO | SILLON<br>ARMCHAIR<br>FAUTEUIL  | 255.61.J | 6071                | ESP    | 364                  |
| 1    | PIO-PIO | ALMOHADA RIÑONERA CON BANDA<br>LUMBAR CUSHION WITH BAND<br>COUSSIN CALE REIN AVEC PLATE-BANDE | 255.27   | 6071                | ESP    | 35                   |

### Pío-Pío Pag. 45



| UNL. | MOD.    | DESCRIPCIÓN / DESCRIPTION / DESCRIPTION       | REF.     | TELAS FABRIC TISSUS | SERIES | PUNTOS POINTS POINTS |
|------|---------|---|----------|---------------------|--------|----------------------|
| 1    | PIO-PIO | BUTACA<br>SMALL ARMCHAIR<br>PETIT FAUTEUIL    | 255.51   | 3856                | C      | 280                  |
| 1    | PIO-PIO | SILLON PLUS<br>ARMCHAIR PLUS<br>FAUTEUIL PLUS | 255.61.K | 6076                | ESP    | 417                  |

Pío-Pío Pag. 46-47

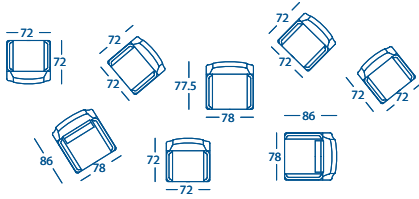

| UNL. | MOD.    | DESCRIPCIÓN / DESCRIPTION / DESCRIPTION   | REF.     | TELAS FABRIC TISSUS | SERIES | PUNTOS POINTS POINTS |
|------|---------|---|----------|---------------------|--------|----------------------|
| 1    | PIO-PIO | BUTACA SMALL ARMCHAIR PETIT FAUTEUIL  | 255.51   | 3856                | C      | 280                  |
| 1    | PIO-PIO | SILLON PLUS ARMCHAIR PLUS FAUTEUIL PLUS   | 255.61.K | 3859                | C      | 348                  |
| 1    | PIO-PIO | BUTACA SMALL ARMCHAIR PETIT FAUTEUIL  | 255.51   | 6076                | ESP    | 329                  |
| 1    | PIO-PIO | BUTACA SMALL ARMCHAIR PETIT FAUTEUIL  | 255.51   | 6055                | ESP    | 329                  |
| 1    | PIO-PIO | SILLON ARMCHAIR FAUTEUIL  | 255.61.J | 6072                | ESP    | 364                  |
| 1    | PIO-PIO | ALMOHADA RIÑONERA CON BANDA LUMBAR CUSHION WITH BAND COUSSIN CALE REIN AVEC PLATE-BANDE | 255.27   | 6071                | ESP    | 35                   |
| 1    | PIO-PIO | BUTACA SMALL ARMCHAIR PETIT FAUTEUIL  | 255.51   | 3856                | C      | 280                  |
| 1    | PIO-PIO | SILLON PLUS ARMCHAIR PLUS FAUTEUIL PLUS   | 255.61.K | 6071                | ESP    | 417                  |
| 1    | PIO-PIO | BUTACA SMALL ARMCHAIR PETIT FAUTEUIL  | 255.51   | 3862                | C      | 280                  |

Ace Pag. 50-51, 53

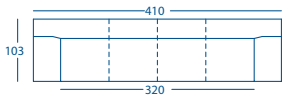

| UNL. | MOD. | DESCRIPCIÓN / DESCRIPTION / DESCRIPTION                          | REF.         | TELAS FABRIC TISSUS | SERIES | PUNTOS POINTS POINTS |
|------|------|--|--------------|---------------------|--------|----------------------|
| 1    | ACE  | SOFA 410 BRAZO ANCHO SOFA 410 WIDE ARM CANAPE 410 BRAS LARGE     | 260.11.ZA1.1 | 1608                | A      | 1650                 |
| 2    | ACE  | ALMOHADA RESPALDO 75X50 BACK CUSHION 75X50 COUSSIN DOSSIER 75X50 | 260.28.HF    | 1608                | A      | 152                  |
| 1    | ACE  | ALMOHADA RESPALDO 60X40 BACK CUSHION 60X40 COUSSIN DOSSIER 60X40 | 260.28.GE    | 1612                | A      | 60                   |

Ace Pag. 52

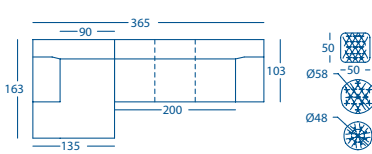

| UNL. | MOD.      | DESCRIPCIÓN / DESCRIPTION / DESCRIPTION   | REF.          | TELAS FABRIC TISSUS | SERIES | PUNTOS POINTS POINTS |
|------|-----------|---|---------------|---------------------|--------|----------------------|
| 1    | ACE       | CHAISE 135X165 BRAZO ANCHO IZDO CHAISE 135X165 WIDE LEFT ARM CHAISE 135X165 BRAS LARGE GAUCHE     | 260.14.PS.1.I | 6057                | ESP    | 841                  |
| 1    | ACE       | MODULO 200 MODULE 200 MODULE 200  | 260.121.W     | 6057                | ESP    | 810                  |
| 1    | ACE       | BRAZO ANCHO DCHO WIDE RIGHT ARM BRAS LARGE DROIT  | 260.131.D     | 6057                | ESP    | 196                  |
| 1    | ACE       | ALMOHADA RESPALDO 60X40 BACK CUSHION 60X40 COUSSIN DOSSIER 60X40                                  | 260.28.GE     | 6050                | ESP    | 70                   |
| 1    | ACE       | ALMOHADA RESPALDO 75X50 BACK CUSHION 75X50 COUSSIN DOSSIER 75X50                                  | 260.28.HF     | 6057                | ESP    | 92                   |
| 1    | MANDARINA | COJIN D48X11.5 CON PELLIZCOS CUSHION D48X11.5 WITH PINCHES COUSSIN D48X11.5 AVEC PINCEMENTS       | 267.24.E.P    | 6043                | ESP    | 49                   |
| 1    | MANDARINA | COJIN D58X15 CON PELLIZCOS CUSHION D58X15 WITH PINCHES COUSSIN D58X15 AVEC PINCEMENTS             | 267.24.F.P    | 6072                | ESP    | 59                   |
| 1    | MANDARINA | COJIN 50X50X15.5 CON PELLIZCOS CUSHION 50X50X15.5 WITH PINCHES COUSSIN 50X50X15.5 AVEC PINCEMENTS | 267.22.FF.P   | 8027                | J      | 66                   |

Ace Pag. 54-55

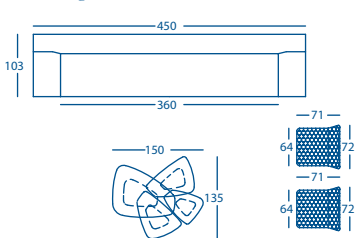

| UNL. | MOD. | DESCRIPCIÓN / DESCRIPTION / DESCRIPTION                            | REF.         | TELAS FABRIC TISSUS | SERIES | PUNTOS POINTS POINTS |
|------|------|--|--------------|---------------------|--------|----------------------|
| 1    | ACE  | SOFA 450 BRAZO ANCHO SOFA 450 WIDE ARM CANAPE 450 BRAS LARGE       | 260.11.ZA5.1 | 1722                | A      | 1722                 |
| 1    | ACE  | ALMOHADA RESPALDO 60X40 BACK CUSHION 60X40 COUSSIN DOSSIER 60X40   | 260.28.GE    | 1612                | A      | 60                   |
| 2    | ACE  | ALMOHADA RESPALDO 75X50 BACK CUSHION 75X50 COUSSIN DOSSIER 75X50   | 260.28.HF    | 1008                | A      | 152                  |
| 1    | TEA  | BUTACA ACOLCHADA QUILTED SMALL ARMCHAIR PETIT FAUTEUIL MATELASSAGE | 250.51.G     | 8022<br>8033        | J      | 352                  |

← Cont.

|   |      |  |            |              |   |     |
|---|------|--|------------|--------------|---|-----|
| 1 | TEA  | BUTACA ACOLCHADA<br>QUILTED SMALL ARMCHAIR<br>PETIT FAUTEUIL MATELASSAGE | 250.51.G   | 8023<br>8032 | J | 352 |
| 1 | ROCK | MESA 62X48X39<br>TABLE 62X48X39<br>TABLE 62X48X39                        | 265.71.GED | 030          | - | 152 |
| 1 | ROCK | MESA 81x58x35<br>TABLE 81x58x35<br>TABLE 81x58x35                        | 265.71.JFD | 301          | - | 184 |
| 1 | ROCK | MESA 81x58x35<br>TABLE 81x58x35<br>TABLE 81x58x35                        | 265.71.JFD | 004          | - | 184 |
| 1 | ROCK | MESA 108x81x31<br>TABLE 108x81x31<br>TABLE 108x81x31                     | 265.71.LJD | 004          | - | 243 |

Ace Pag. 56

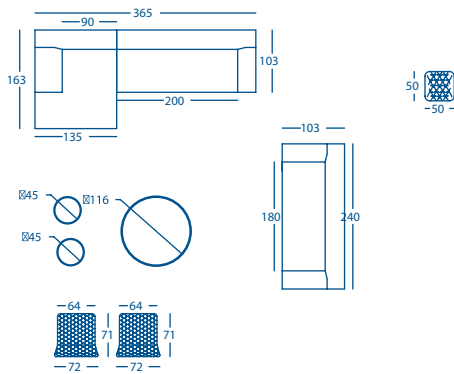

| UNL. | MOD.      | DESCRIPCIÓN / DESCRIPTION / DESCRIPTION   | REF.          | TELAS<br>FABRIC<br>TISSUS | SERIES   | PUNTOS<br>POINTS<br>POINTS |
|------|-----------|---|---------------|---------------------------|----------|----------------------------|
| 1    | ACE       | CHAISE 135X165 BRAZO ANCHO IZDO<br>CHAISE 135X165 WIDE LEFT ARM<br>CHAISE 135X165 BRAS LARGE GAUCHE     | 260.14.PS.1.J | 6057                      | ESP      | 841                        |
| 1    | ACE       | MODULO 200<br>MODULE 200<br>MODULE 200  | 260.121.W     | 6057                      | ESP      | 810                        |
| 1    | ACE       | BRAZO ANCHO DCHO<br>WIDE RIGHT ARM<br>BRAS LARGE DROIT  | 260.131.D     | 6057                      | ESP      | 196                        |
| 3    | ACE       | ALMOHADA RESPALDO 75X50<br>BACK CUSHION 75X50<br>COUSSIN DOSSIER 75X50                                  | 260.28.HF     | 6050                      | ESP      | 276                        |
| 1    | MANDARINA | COJIN 50X50X15.5 CON PELLIZCOS<br>CUSHION 50X50X15.5 WITH PINCHES<br>COUSSIN 50X50X15.5 AVEC PINCEMENTS | 267.22.FF.P   | 6040                      | ESP      | 55                         |
| 1    | MANDARINA | COJIN 50X50X15.5 CON PELLIZCOS<br>CUSHION 50X50X15.5 WITH PINCHES<br>COUSSIN 50X50X15.5 AVEC PINCEMENTS | 267.22.FF.P   | 6081                      | ESP      | 55                         |
| 1    | ACE       | SOFA 240 BRAZO ESTRECHO<br>SOFA 240 NARROW ARM<br>CANAPE 240 BRAS ETROIT                                | 260.11.Z1.2   | 6057                      | ESP      | 1071                       |
| 2    | ACE       | ALMOHADA RESPALDO 60X40<br>BACK CUSHION 60X40<br>COUSSIN DOSSIER 60X40                                  | 260.28.GE     | 6050                      | ESP      | 140                        |
| 1    | ACE       | ALMOHADA RESPALDO 60X40<br>BACK CUSHION 60X40<br>COUSSIN DOSSIER 60X40                                  | 260.28.GE     | 1612                      | A        | 60                         |
| 1    | TEA       | BUTACA ACOLCHADA<br>QUILTED SMALL ARMCHAIR<br>PETIT FAUTEUIL MATELASSAGE                                | 250.51.G      | 8022<br>8033              | J        | 352                        |
| 1    | TEA       | BUTACA ACOLCHADA<br>QUILTED SMALL ARMCHAIR<br>PETIT FAUTEUIL MATELASSAGE                                | 250.51.G      | 8023<br>8032              | J        | 352                        |
| 1    | CHAT      | TABURETE D45X44<br>STOOL D45X44<br>TABOURET D45X44  | 263.151.EE    | 6076<br>6080              | ESP      | 141                        |
| 1    | CHAT      | TABURETE D45X44<br>STOOL D45X44<br>TABOURET D45X44  | 263.151.EE    | 6074<br>3855              | ESP<br>C | 133                        |
| 1    | CHAT      | PUF D116X36<br>POUF D116X36<br>POUF D116X36   | 263.151.MD    | 3855<br>3857              | C        | 257                        |

Ace Pag. 57

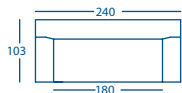

| UNL. | MOD. | DESCRIPCIÓN / DESCRIPTION / DESCRIPTION                                  | REF.        | TELAS<br>FABRIC<br>TISSUS | SERIES | PUNTOS<br>POINTS<br>POINTS |
|------|------|--|-------------|---------------------------|--------|----------------------------|
| 1    | ACE  | SOFA 240 BRAZO ESTRECHO<br>SOFA 240 NARROW ARM<br>CANAPE 240 BRAS ETROIT | 260.11.Z1.2 | 6057                      | ESP    | 1071                       |
| 2    | ACE  | ALMOHADA RESPALDO 75X50<br>BACK CUSHION 75X50<br>COUSSIN DOSSIER 75X50   | 260.28.HF   | 6050                      | ESP    | 184                        |

Chat Pag. 60-61

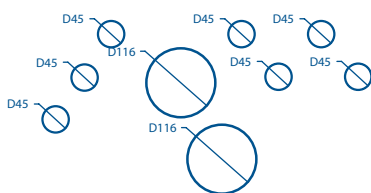

| UNL. | MOD. | DESCRIPCIÓN / DESCRIPTION / DESCRIPTION            | REF.       | TELAS<br>FABRIC<br>TISSUS | SERIES   | PUNTOS<br>POINTS<br>POINTS |
|------|------|--|------------|---------------------------|----------|----------------------------|
| 1    | CHAT | TABURETE D45X44<br>STOOL D45X44<br>TABOURET D45X44 | 263.151.EE | 6076<br>6080              | ESP      | 141                        |
| 1    | CHAT | TABURETE D45X44<br>STOOL D45X44<br>TABOURET D45X44 | 263.151.EE | 6074<br>3855              | ESP<br>C | 133                        |
| 1    | CHAT | PUF D116X36<br>POUF D116X36<br>POUF D116X36        | 263.151.MD | 3855<br>3857              | C        | 115                        |

← Cont.

|   |      |  |            |              |          |     |
|---|------|--|------------|--------------|----------|-----|
| 1 | CHAT | PUF D116X36<br>POUF D116X36<br>POUF D116X36        | 263.151.MD | 6074<br>3857 | ESP<br>C | 295 |
| 1 | CHAT | TABURETE D45X44<br>STOOL D45X44<br>TABOURET D45X44 | 263.151.EE | 6070<br>3855 | ESP<br>C | 133 |
| 1 | CHAT | TABURETE D45X44<br>STOOL D45X44<br>TABOURET D45X44 | 263.151.EE | 3855<br>6080 | C<br>ESP | 133 |
| 1 | CHAT | TABURETE D45X44<br>STOOL D45X44<br>TABOURET D45X44 | 263.151.EE | 6070<br>8081 | ESP      | 141 |
| 1 | CHAT | TABURETE D45X44<br>STOOL D45X44<br>TABOURET D45X44 | 263.151.EE | 6077<br>6076 | ESP      | 141 |
| 1 | CHAT | TABURETE D45X44<br>STOOL D45X44<br>TABOURET D45X44 | 263.151.EE | 3857<br>6074 | C<br>ESP | 133 |

Chat Pag. 62

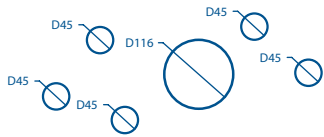

| UNI. | MOD. | DESCRIPCIÓN / DESCRIPTION / DESCRIPTION            | REF.       | TELAS<br>FABRIC<br>TISSUS | SERIES   | PUNTOS<br>POINTS<br>POINTS |
|------|------|--|------------|---------------------------|----------|----------------------------|
| 1    | CHAT | TABURETE D45X44<br>STOOL D45X44<br>TABOURET D45X44 | 263.151.EE | 3857<br>6074              | C / ESP  | 133                        |
| 1    | CHAT | TABURETE D45X44<br>STOOL D45X44<br>TABOURET D45X44 | 263.151.EE | 3855<br>6080              | C<br>ESP | 133                        |
| 1    | CHAT | TABURETE D45X44<br>STOOL D45X44<br>TABOURET D45X44 | 263.151.EE | 6077<br>6076              | ESP      | 141                        |
| 1    | CHAT | PUF D116X36<br>POUF D116X36<br>POUF D116X36        | 263.151.MD | 3855<br>3857              | C        | 257                        |
| 1    | CHAT | TABURETE D45X44<br>STOOL D45X44<br>TABOURET D45X44 | 263.151.EE | 6076<br>6080              | ESP      | 141                        |
| 1    | CHAT | TABURETE D45X44<br>STOOL D45X44<br>TABOURET D45X44 | 263.151.EE | 3858<br>3856              | C        | 115                        |

Chat Pag. 63-65

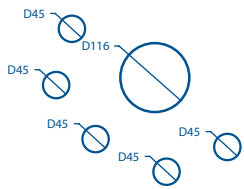

| UNI. | MOD. | DESCRIPCIÓN / DESCRIPTION / DESCRIPTION            | REF.       | TELAS<br>FABRIC<br>TISSUS | SERIES   | PUNTOS<br>POINTS<br>POINTS |
|------|------|--|------------|---------------------------|----------|----------------------------|
| 1    | CHAT | TABURETE D45X44<br>STOOL D45X44<br>TABOURET D45X44 | 263.151.EE | 3855<br>6080              | C<br>ESP | 133                        |
| 1    | CHAT | TABURETE D45X44<br>STOOL D45X44<br>TABOURET D45X44 | 263.151.EE | 3858<br>3856              | C        | 115                        |
| 1    | CHAT | TABURETE D45X44<br>STOOL D45X44<br>TABOURET D45X44 | 263.151.EE | 6076<br>6080              | ESP      | 141                        |
| 1    | CHAT | TABURETE D45X44<br>STOOL D45X44<br>TABOURET D45X44 | 263.151.EE | 3857<br>6074              | C / ESP  | 133                        |
| 1    | CHAT | PUF D116X36<br>POUF D116X36<br>POUF D116X36        | 263.151.MD | 6074<br>3857              | ESP / C  | 295                        |
| 1    | CHAT | TABURETE D45X44<br>STOOL D45X44<br>TABOURET D45X44 | 263.151.EE | 6070<br>3855              | ESP / C  | 133                        |

Rock Pag. 68

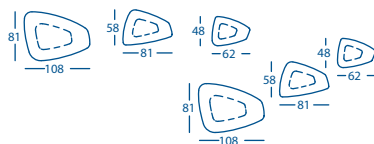

| UNI. | MOD. | DESCRIPCIÓN / DESCRIPTION / DESCRIPTION              | REF.       | TELAS<br>FABRIC<br>TISSUS | SERIES | PUNTOS<br>POINTS<br>POINTS |
|------|------|--|------------|---------------------------|--------|----------------------------|
| 2    | ROCK | MESA 62X48X39<br>TABLE 62X48X39<br>TABLE 62X48X39    | 265.71.GED | 002                       | -      | 152                        |
| 2    | ROCK | MESA 81x58x35<br>TABLE 81x58x35<br>TABLE 81x58x35    | 265.71.JFD | 004                       | -      | 184                        |
| 2    | ROCK | MESA 108x81x31<br>TABLE 108x81x31<br>TABLE 108x81x31 | 265.71.LJD | 002                       | -      | 486                        |

Rock Pag. 70-71



| UNI. | MOD. | DESCRIPCIÓN / DESCRIPTION / DESCRIPTION              | REF.       | TELAS<br>FABRIC<br>TISSUS | SERIES | PUNTOS<br>POINTS<br>POINTS |
|------|------|--|------------|---------------------------|--------|----------------------------|
| 1    | ROCK | MESA 62X48X39<br>TABLE 62X48X39<br>TABLE 62X48X39    | 265.71.GED | 301                       | -      | 152                        |
| 1    | ROCK | MESA 81x58x35<br>TABLE 81x58x35<br>TABLE 81x58x35    | 265.71.JFD | 301                       | -      | 184                        |
| 1    | ROCK | MESA 108x81x31<br>TABLE 108x81x31<br>TABLE 108x81x31 | 265.71.LJD | 301                       | -      | 243                        |



Rock Pag. 72-73

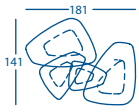

| UNL. | MOD. | DESCRIPCIÓN / DESCRIPTION / DESCRIPTION              | REF.       | TELAS FABRIC TISSUS | SERIES | PUNTOS POINTS POINTS |
|------|------|--|------------|---------------------|--------|----------------------|
| 1    | ROCK | MESA 62X48X39<br>TABLE 62X48X39<br>TABLE 62X48X39    | 265.71.GED | 030                 | -      | 152                  |
| 1    | ROCK | MESA 81x58x35<br>TABLE 81x58x35<br>TABLE 81x58x35    | 265.71.JFD | 210                 | -      | 217                  |
| 1    | ROCK | MESA 108x81x31<br>TABLE 108x81x31<br>TABLE 108x81x31 | 265.71.LJD | 004                 | -      | 243                  |
| 1    | ROCK | MESA 108x81x31<br>TABLE 108x81x31<br>TABLE 108x81x31 | 265.71.LJD | 002                 | -      | 244                  |

Rock Pag. 74

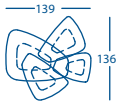

| UNL. | MOD. | DESCRIPCIÓN / DESCRIPTION / DESCRIPTION              | REF.       | TELAS FABRIC TISSUS | SERIES | PUNTOS POINTS POINTS |
|------|------|--|------------|---------------------|--------|----------------------|
| 1    | ROCK | MESA 62X48X39<br>TABLE 62X48X39<br>TABLE 62X48X39    | 265.71.GED | 030                 | -      | 152                  |
| 1    | ROCK | MESA 81x58x35<br>TABLE 81x58x35<br>TABLE 81x58x35    | 265.71.JFD | 004                 | -      | 184                  |
| 1    | ROCK | MESA 81x58x35<br>TABLE 81x58x35<br>TABLE 81x58x35    | 265.71.JFD | 301                 | -      | 184                  |
| 1    | ROCK | MESA 108x81x31<br>TABLE 108x81x31<br>TABLE 108x81x31 | 265.71.LJD | 004                 | -      | 243                  |

Rock Pag. 75



| UNL. | MOD. | DESCRIPCIÓN / DESCRIPTION / DESCRIPTION   | REF.       | TELAS FABRIC TISSUS | SERIES | PUNTOS POINTS POINTS |
|------|------|---|------------|---------------------|--------|----------------------|
| 1    | ROCK | MESA ELEVABLE 62X48X39/60<br>LIFTING TABLE 62X48X39/60<br>TABLE ELEVATEUR 62X48X39/60 | 265.76.GED | 002                 | -      | 227                  |

Tea. 78-81

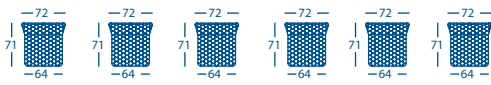

| UNL. | MOD. | DESCRIPCIÓN / DESCRIPTION / DESCRIPTION                                  | REF.     | TELAS FABRIC TISSUS | SERIES | PUNTOS POINTS POINTS |
|------|------|--|----------|---------------------|--------|----------------------|
| 1    | TEA  | BUTACA ACOLCHADA<br>QUILTED SMALL ARMCHAIR<br>PETIT FAUTEUIL MATELASSAGE | 250.51.G | 8025<br>8028        | J      | 352                  |
| 1    | TEA  | BUTACA ACOLCHADA<br>QUILTED SMALL ARMCHAIR<br>PETIT FAUTEUIL MATELASSAGE | 250.51.G | 8021<br>8030        | J      | 352                  |
| 1    | TEA  | BUTACA ACOLCHADA<br>QUILTED SMALL ARMCHAIR<br>PETIT FAUTEUIL MATELASSAGE | 250.51.G | 8022<br>8033        | J      | 352                  |
| 1    | TEA  | BUTACA ACOLCHADA<br>QUILTED SMALL ARMCHAIR<br>PETIT FAUTEUIL MATELASSAGE | 250.51.G | 8024<br>8031        | J      | 352                  |
| 1    | TEA  | BUTACA ACOLCHADA<br>QUILTED SMALL ARMCHAIR<br>PETIT FAUTEUIL MATELASSAGE | 250.51.G | 8020<br>8029        | J      | 352                  |
| 1    | TEA  | BUTACA ACOLCHADA<br>QUILTED SMALL ARMCHAIR<br>PETIT FAUTEUIL MATELASSAGE | 250.51.G | 8023<br>8032        | J      | 352                  |

Tea Pag. 82-83



| UNL. | MOD. | DESCRIPCIÓN / DESCRIPTION / DESCRIPTION                               | REF.       | TELAS FABRIC TISSUS | SERIES | PUNTOS POINTS POINTS |
|------|------|---|------------|---------------------|--------|----------------------|
| 1    | TEA  | SILLON 94 ACOLCHADO<br>QUILTED ARMCHAIR 94<br>FAUTEUIL 94 MATELASSAGE | 250.61.K.G | 3864                | C      | 440                  |

Tea Pag. 84-85

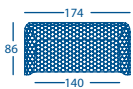

| UNL. | MOD. | DESCRIPCIÓN / DESCRIPTION / DESCRIPTION                          | REF.       | TELAS FABRIC TISSUS | SERIES | PUNTOS POINTS POINTS |
|------|------|--|------------|---------------------|--------|----------------------|
| 1    | TEA  | SOFA 174 ACOLCHADO<br>QUILTED SOFA 174<br>CANAPE 174 MATELASSAGE | 250.61.T.G | 3856                | C      | 633                  |

Tea Pag. 86-87

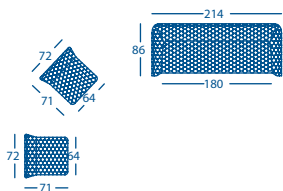

| UNL. | MOD. | DESCRIPCIÓN / DESCRIPTION / DESCRIPTION                                  | REF.       | TELAS FABRIC TISSUS | SERIES | PUNTOS POINTS POINTS |
|------|------|--|------------|---------------------|--------|----------------------|
| 1    | TEA  | BUTACA ACOLCHADA<br>QUILTED SMALL ARMCHAIR<br>PETIT FAUTEUIL MATELASSAGE | 250.51.G   | 8021<br>8030        | J      | 352                  |
| 1    | TEA  | BUTACA ACOLCHADA<br>QUILTED SMALL ARMCHAIR<br>PETIT FAUTEUIL MATELASSAGE | 250.51.G   | 8024<br>8031        | J      | 352                  |
| 1    | TEA  | SOFA 214 ACOLCHADO<br>QUILTED SOFA 214<br>CANAPE 214 MATELASSAGE         | 250.61.X.G | 8027<br>3859        | J / C  | 856                  |

← Cont.

|   |     |  |        |              |        |    |
|---|-----|--|--------|--------------|--------|----|
| 2 | TEA | ALMOHADA RIÑONERA<br>LUMBAR CUSHION<br>COUSSIN CALE REIN | 250.27 | 8027<br>3859 | J<br>C | 72 |
|---|-----|--|--------|--------------|--------|----|

Tea Pag. 88-89

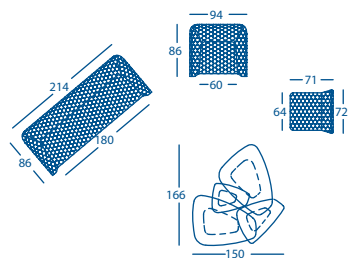

| UNL. | MOD. | DESCRIPCIÓN / DESCRIPTION / DESCRIPTION   | REF.       | TELAS<br>FABRIC<br>TISSUS | SERIES | PUNTOS<br>POINTS<br>POINTS |
|------|------|---|------------|---------------------------|--------|----------------------------|
| 1    | TEA  | SOFA 214 ACOLCHADO<br>QUILTED SOFA 214<br>CANAPE 214 MATELASSAGE                      | 250.61.X.G | 8027<br>3859              | J<br>C | 856                        |
| 1    | TEA  | SILLON 94 ACOLCHADO<br>QUILTED ARMCHAIR 94<br>FAUTEUIL 94 MATELASSAGE                 | 250.61.K.G | 8027<br>3859              | J<br>C | 510                        |
| 1    | TEA  | BUTACA ACOLCHADA<br>QUILTED SMALL ARMCHAIR<br>PETIT FAUTEUIL MATELASSAGE              | 250.51.G   | 8022<br>8033              | J      | 352                        |
| 1    | ROCK | MESA 81x58x35<br>TABLE 81x58x35<br>TABLE 81x58x35                                     | 265.71.JFD | 004                       |        | 184                        |
| 1    | ROCK | MESA 108x81x31<br>TABLE 108x81x31<br>TABLE 108x81x31                                  | 265.71.LJD | 004                       |        | 243                        |
| 1    | ROCK | MESA 108x81x31<br>TABLE 108x81x31<br>TABLE 108x81x31                                  | 265.71.LJD | 002                       |        | 243                        |
| 1    | ROCK | MESA ELEVABLE 62X48X39/60<br>LIFTING TABLE 62X48X39/60<br>TABLE ELEVATEUR 62X48X39/60 | 265.76.GED | 002                       |        | 227                        |

Tea Pag. 90-91

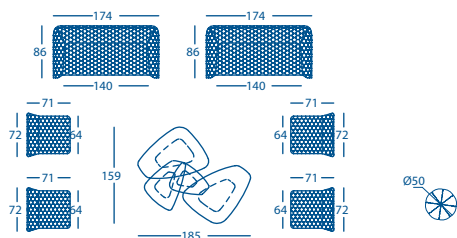

| UNL. | MOD.      | DESCRIPCIÓN / DESCRIPTION / DESCRIPTION                                   | REF.       | TELAS<br>FABRIC<br>TISSUS | SERIES | PUNTOS<br>POINTS<br>POINTS |
|------|-----------|---|------------|---------------------------|--------|----------------------------|
| 1    | TEA       | SOFA 174 ACOLCHADO<br>QUILTED SOFA 174<br>CANAPE 174 MATELASSAGE          | 250.61.T.G | 3856                      | C      | 633                        |
| 1    | MANDARINA | COJIN D40X14 FRUNCIDO<br>WRINKLED CUSHION D40X14<br>COUSSIN D40X14 FRONCÉ | 267.24.E.O | 6079                      | ESP    | 49                         |
| 1    | TEA       | SOFA 174 ACOLCHADO<br>QUILTED SOFA 174<br>CANAPE 174 MATELASSAGE          | 250.61.T.G | 3864                      | C      | 633                        |
| 2    | TEA       | ALMOHADA RIÑONERA<br>LUMBAR CUSHION<br>COUSSIN CALE REIN                  | 250.27     | 8027<br>3859              | J<br>C | 72                         |
| 1    | TEA       | BUTACA ACOLCHADA<br>QUILTED SMALL ARMCHAIR<br>PETIT FAUTEUIL MATELASSAGE  | 250.51.G   | 8021<br>8030              | J      | 352                        |
| 1    | TEA       | BUTACA ACOLCHADA<br>QUILTED SMALL ARMCHAIR<br>PETIT FAUTEUIL MATELASSAGE  | 250.51.G   | 8024<br>8031              | J      | 352                        |
| 1    | TEA       | BUTACA ACOLCHADA<br>QUILTED SMALL ARMCHAIR<br>PETIT FAUTEUIL MATELASSAGE  | 250.51.G   | 8022<br>8033              | J      | 352                        |
| 1    | TEA       | BUTACA ACOLCHADA<br>QUILTED SMALL ARMCHAIR<br>PETIT FAUTEUIL MATELASSAGE  | 250.51.G   | 8025<br>8028              | J      | 352                        |
| 1    | ROCK      | MESA 62X48X39<br>TABLE 62X48X39<br>TABLE 62X48X39                         | 265.71.GED | 030                       | -      | 152                        |
| 1    | ROCK      | MESA 81x58x35<br>TABLE 81x58x35<br>TABLE 81x58x35                         | 265.71.JFD | 210                       | -      | 217                        |
| 1    | ROCK      | MESA 108x81x31<br>TABLE 108x81x31<br>TABLE 108x81x31                      | 265.71.LJD | 004                       | -      | 243                        |
| 1    | ROCK      | MESA 108x81x31<br>TABLE 108x81x31<br>TABLE 108x81x31                      | 265.71.LJD | 002                       | -      | 243                        |

Mandarinas Pag. 94

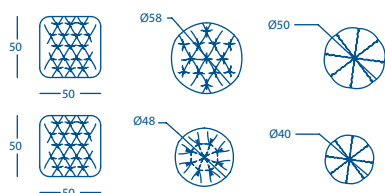

| UNL. | MOD.      | DESCRIPCIÓN / DESCRIPTION / DESCRIPTION   | REF.         | TELAS<br>FABRIC<br>TISSUS | SERIES | PUNTOS<br>POINTS<br>POINTS |
|------|-----------|---|--------------|---------------------------|--------|----------------------------|
| 1    | MANDARINA | COJIN 50X50X15.5 CON PELLIZCOS<br>CUSHION 50X50X15.5 WITH PINCHES<br>COUSSIN 50X50X15.5 AVEC PINCEMENTS | 267.22.F.F.P | 6081                      | ESP    | 55                         |
| 1    | MANDARINA | COJIN D58X15 CON PELLIZCOS<br>CUSHION D58X15 WITH PINCHES<br>COUSSIN D58X15 AVEC PINCEMENTS             | 267.24.F.P   | 6071                      | ESP    | 59                         |
| 1    | MANDARINA | COJIN D50X16.5 FRUNCIDO<br>WRINKLED CUSHION D50X16.5<br>COUSSIN D50X16.5 FRONCÉ                         | 267.24.F.O   | 6079                      | ESP    | 59                         |
| 1    | MANDARINA | COJIN 50X50X15.5 CON PELLIZCOS<br>CUSHION 50X50X15.5 WITH PINCHES<br>COUSSIN 50X50X15.5 AVEC PINCEMENTS | 267.22.F.F.P | 6080                      | ESP    | 55                         |
| 1    | MANDARINA | COJIN D48X11.5 CON PELLIZCOS<br>CUSHION D48X11.5 WITH PINCHES<br>COUSSIN D48X11.5 AVEC PINCEMENTS       | 267.24.E.P   | 6072                      | ESP    | 49                         |
| 1    | MANDARINA | COJIN D40X14 FRUNCIDO<br>WRINKLED CUSHION D40X14<br>COUSSIN D40X14 FRONCÉ                               | 267.24.E.O   | 6070                      | ESP    | 49                         |

## CALIDAD

La satisfacción de nuestros clientes y la calidad de nuestros productos es un elemento central en la política de Sancal, por ello la empresa apuesta por la Mejora Continua a través de un riguroso Sistema de Gestión de la Calidad que se rige por las normativas ISO 9000 y es anualmente supervisado por Bureau Veritas. Además, la calidad de nuestros productos está garantizada por el saber hacer de nuestro personal y por la supervisión directa de una fabricación made in Spain.

## ENSAYOS

Sancal ensaya sus productos en los laboratorios de CETEM y/o de AIDIMA según las normativas UNE (Española) y UNE EN (Europea) para usos en espacios públicos.

El Símbolo Calidad Controlada certifica a aquellos muebles que han superado diferentes ensayos y reconoce que son adecuados para el uso al que están destinados.

Los test específicos a los que son sometidos nuestros productos comprueban la Durabilidad; la Estabilidad; la Resistencia estática; la Resistencia a impactos y caídas y la Seguridad de los mismos.

Según el tipo de productos las normas que aplicamos son:

| ASIENTOS         |  |
|------------------|--|
| Sofás y bancadas |  |
| Norma española   | UNE 11012:1989   |
| Especificación   | UNE 11021.2:1992 Nivel 4/5 (uso público normal/severo) |
| Norma europea    | UNE EN 15373:2007                                      |
| Especificación   | Nivel 2 (uso no doméstico)                             |
| Sillas y butacas |  |
| Norma española   | UNE 11010:1989   |
| Especificación   | UNE 11020.2:1992 Nivel 4/5 (uso público normal/severo) |
| Norma europea    | UNE EN 15373:2007                                      |
| Especificación   | Nivel 2 (uso no doméstico)                             |
| MESAS            |  |
| Norma            | UNE 11014:1989   |
| Especificación   | UNE 11022.2:1992 Nivel 4/5 (uso público normal/severo) |

## ECOLOGÍA

La conservación del medio ambiente nos preocupa y ha preocupado desde la fundación de la empresa. El consumo sostenible es nuestra máxima y el reciclaje es una realidad para todo el personal de Sancal. Asimismo el tratamiento que damos a nuestros residuos cumple con las normativas europeas correspondientes y la madera empleada en nuestros productos proviene de bosques renovables. La Región de Murcia ha concedido a Sancal el distintivo de Empresa Comprometida con el Desarrollo Sostenible.

## GARANTÍAS

Sancal garantiza todos sus productos hasta 2 años a partir de la fecha de compra indicada en la factura.

Estas garantías son válidas exclusivamente cuando el producto es empleado en aquellas actividades para las que fue concebido. La garantía queda revocada automáticamente en caso de un uso inapropiado del producto o de la manipulación de los componentes del mismo.

## QUALITY

The main aim of Sancal's policy is to achieve customer satisfaction and quality products, thus the firm implements Ongoing Improvements through a thorough System of Quality Management ruled by the ISO 9000 standard and it is annually supervised by Bureau Veritas. Moreover, quality is guaranteed by our personnel's know-how and the direct monitoring of our manufactured products, which bear the made in Spain guarantee.

## TESTS

Sancal tests its products in the CETEM and/or AIDIMA laboratories depending on the UNE (Spanish) and UNE EN (European) standard for use in public spaces.

The Quality Controlled Symbol certifies all pieces of furniture that have passed different tests and recognises that they are suitable for the use for which they were designed.

The specific tests to which our products are subject to check: durability; stability; static resistance; resistance to impacts and its security.

Depending on the type of products, the standards applied are:

| SEATS                     |  |
|---------------------------|--|
| Sofas and benches         |  |
| Spanish standard          | UNE 11012:1989                                       |
| Specification             | UNE 11021.2:1992 Nivel 4/5 (normal/harsh public use) |
| European standard         | UNE EN 15373:2007                                    |
| Specification             | Nivel 2 (domestic use)                               |
| Sofas and small armchairs |  |
| Spanish standard          | UNE 11010:1989                                       |
| Specification             | UNE 11020.2:1992 Nivel 4/5 (normal/harsh public use) |
| Norma europea             | UNE EN 15373:2007                                    |
| Especificación            | Nivel 2 (domestic use)                               |
| TABLES                    |  |
| Standard                  | UNE 11014:1989                                       |
| Specification             | UNE 11022.2:1992 Nivel 4/5 (normal/harsh public use) |

## ECOLOGY

We are concerned with environmental conservation, and have been since the company was established. Sustainable consumption is our motto and recycling is a reality for all Sancal personnel. The treatment we give our resources complies with the relevant European regulations, and the wood used in our products comes from renewable forests. The Region of Murcia has conferred distinction on Sancal as a Company Committed to Sustained Development.

## GUARANTEES

Sancal guarantees all its products for up to 2 years from the purchase date stated on the invoice. These guarantees are only valid when the product is used in those applications for which it was made. Guarantee will be automatically revoked in the event of inappropriate product use.

## QUALITE

La satisfaction de nos clients et la qualité de nos produits sont des facteurs primordiaux dans notre politique. Pour cela, Sancal s'engage à l'amélioration continue au travers de systèmes de gestion et de qualité rigoureux, régis par les normes ISO 9000, et annuellement vérifiés par le Bureau Veritas. De plus, la qualité de nos produits est garantie par le savoir-faire de notre personnel et la qualité de fabrication Made in Spain.

## TESTS PRODUCTS

Sancal teste ses produits dans des laboratoires du CETEM et/ou de l'AIDIMA selon les normes UNE (espagnole) et UNE EN (européenne) pour des utilisations en espaces publics. Le Symbole Qualité Contrôlée certifie que les meubles ayant subi les différents tests sont bien adaptés à l'utilisation à laquelle ils sont destinés. Les tests spécifiques auxquels sont soumis les produits vérifient leur durabilité, leur stabilité, la résistance statique, la résistance aux impacts et aux chutes, et la sécurité des produits.

Selon le type de produit, les normes que nous appliquons sont:

| ASSISES               |   |
|-----------------------|---|
| Canapes et banquettes |   |
| Norme espagnole       | UNE 11012:1989  |
| Spécification         | UNE 11021.2:1992 Niveau 4/5 (utilisation publique normale/sévère) |
| Norme européenne      | UNE EN 14749: 2007  |
| Spécification         | Niveau 2 (utilisation non domestique)                             |
| Chaises et fauteuils  |   |
| Norme espagnole       | UNE 11010:1989  |
| Spécification         | UNE 11020.2:1992 Niveau 4/5 (utilisation publique normale/sévère) |
| Norme européenne      | UNE EN 14749: 2007  |
| Spécification         | Niveau 2 (utilisation non domestique)                             |
| TABLES                |   |
| Norme                 | UNE 11014:1989  |
| Spécification         | UNE 11022.2:1992 Niveau 4/5 (utilisation publique normale/sévère) |

## ECOLOGIE

La préservation de la nature nous préoccupe et a toujours préoccupé l'usine depuis sa création. La consommation limitée est notre devise et le recyclage est une réalité pour tout notre personnel. Ainsi le traitement appliqué à nos résidus est en accord total avec les lois normes européennes et le bois employé dans nos produits provient de forêt renouvelables. Actuellement, nous sommes sous procès de certification ISO14001 et grâce à notre travail écologique, la région de Murcia nous a décerné le titre d'Entreprise Engagée pour le Développement Durable.

## GARANTIE

Sancal garantit tous ses produits 2 ans et jusqu'à 10 ans pour les structures en bois de ses canapés, à partir de la date d'achat indiquée sur la facture. Ces garanties sont valides uniquement si le produit a subi une utilisation conforme à celle pour lequel il était destiné. La garantie est automatiquement révoquée dans le cas d'une utilisation non adaptée.

---

# SANCAL

REF. 10011

Art direction & styling **juan ibañez**  
Fotografía photography **marcelo martínez**  
Coordinación coordination **esther castaño-lópez**  
Proyecto gráfico graphic project **juan ibañez**

Impresión Gráficas .....  
Copyright © Sancal Diseño S.L. 2010

**SANCAL DISEÑO, S.L.**  
Pol. Ind. La Herrada C/ Príncipe de Asturias,  
18 30510 Yecla (Murcia) Spain  
Tel Esp. +34 968 75 15 03  
Tel. Eng. +34 968 71 90 62  
Tel. Fra. +34 968 71 90 61  
Fax +34 968 79 40 62  
e-mail web@sancal.com  
**www.sancal.com**



