

REF. 3.217

MQ2102 Escritorio de Oficina

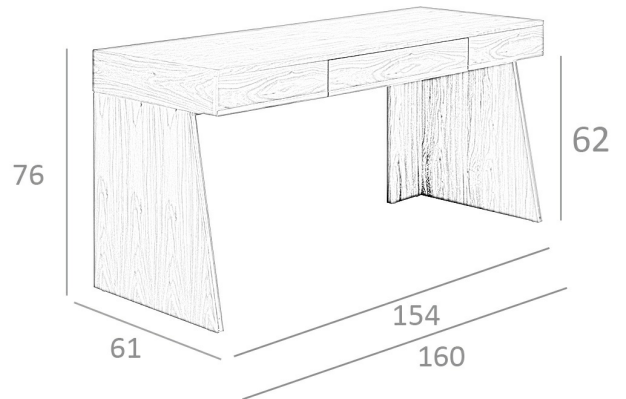

MEDIDAS

Medidas: 160 x 61 x 76 cm.

Peso: 50 Kg.

EMBALAJE

166 x 67 x 20 cm. / 32 Kg.

66 x 68 x 30 cm. / 22 Kg.

VOLUMEN

0,36 m3

PRODUCTO

Chapa Nogal - STOCK

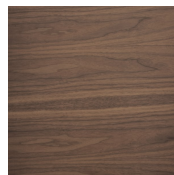

PATAS

Material Patas: Chapa Nogal

