

Dome 60/01

Diseño / Design:

Benedetta Tagliabue | EMBT / 2015

Tipología: Suspensión

Typology: Pendant lamp

Ambiente: Interior

Environment: Indoor

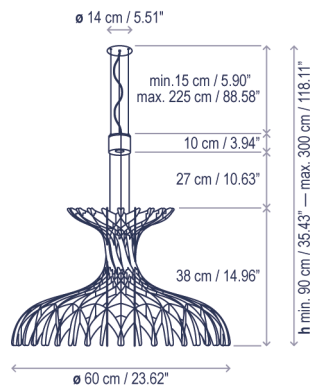

Descripción técnica / Technical description:



Peso Neto: 2,38 kg
Net Weight: 2,38 kg



1 Caja/Box | 67 x 67 x 57 cm | 0,2559 m³
Peso bruto / Gross Weight: 4,63 kg

Materiales: Hierro, Aluminio, Madera
acabado haya.

Materials: Iron, Aluminum, Wood finished
beech.

La fuente de luz está situada sobre la
estructura, proyectando bellos mosaicos de
luz en las superficies inferiores.

The light is above the structure to illuminate
throughout the open and diffused portions
casting beautiful shadow patterns on surfaces
below.

Consulte la tabla de reguladores TRIAC
recomendados en la página 242.

Please check the list of recommended TRIAC
dimmers at page 242.

No personalizable

Not customizable

Certificaciones
Certifications



Descripción lámpara / Lamps description:



230V
50Hz

IP-20



12,5 W LED / CRI: 90 / 2700K
1352 lm fuente de luz / light source



Ref

Acabados / Finishing

Ean13

2580621400/P829

Regulable Triac - Blanco Mate
Pantalla Madera Natural
Dimmable Triac - Matte White
Natural Wood Shade

8435493705897

bover
barcelona lights

Avda. Catalunya 173
Poligon Ind. Sud
08440 Cardedeu
Barcelona, Spain

T. +34 938 713 152
F. +34 938 462 089
info@bover.es
www.bover.es

Familia / Family: Dome

60/01



60/02



90



180

