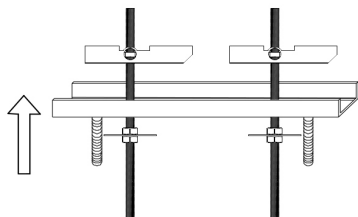
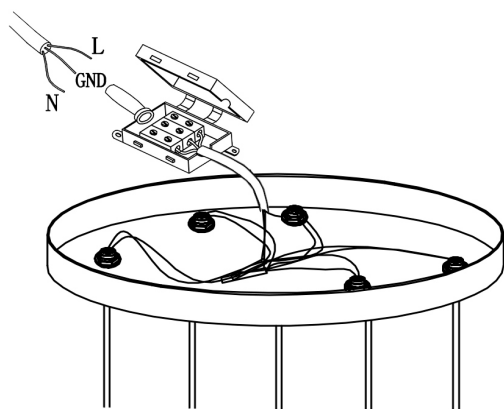
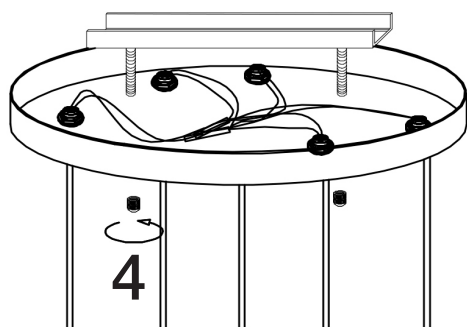

ATENCIÓN: Schuller recomienda que utilice los balancines suministrados en la instalación de esta lámpara.

1

3

4

Ajustar la longitud de los cables antes de instalar. Colocar las tulipas una vez instalada la lámpara en su lugar definitivo.

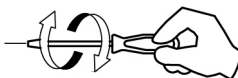
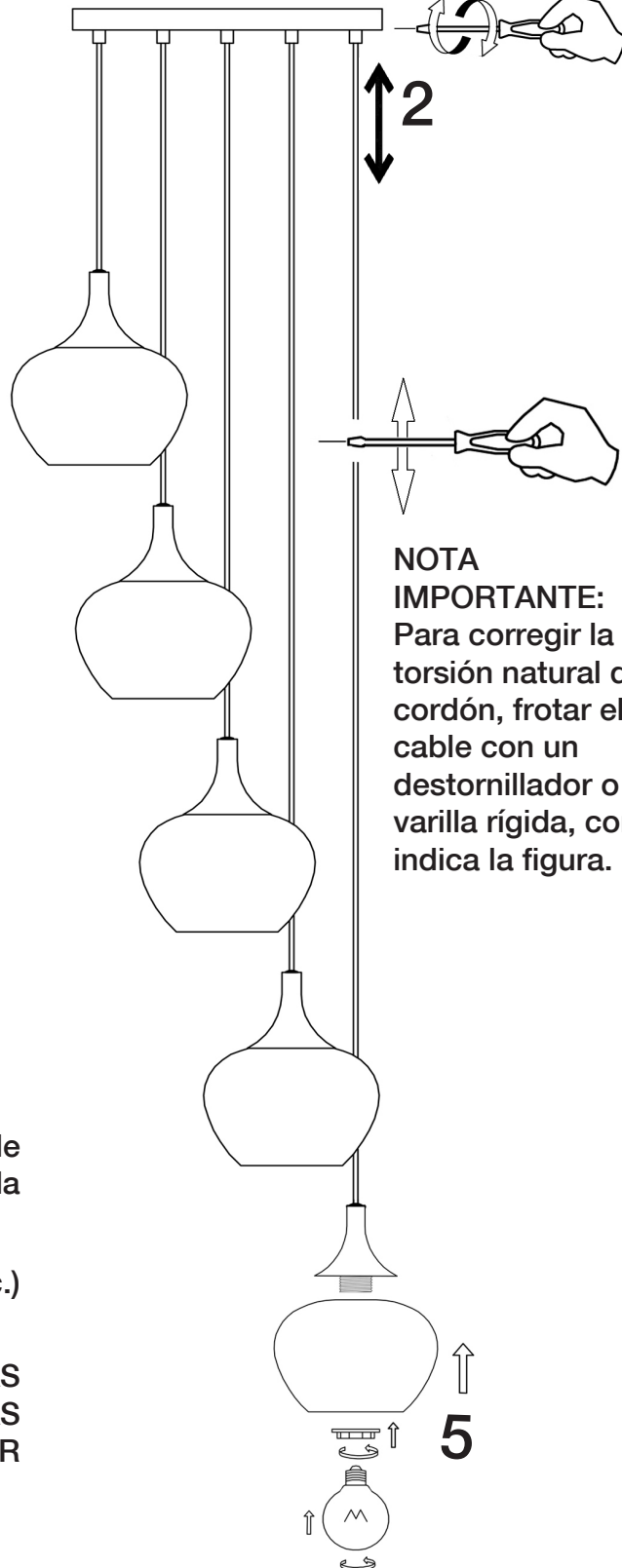
En la manipulación (montaje, limpieza, etc.) evite que los cristales se golpeen entre sí.

LA FABRICACIÓN ARTESANAL DE ESTAS TULIPAS DE CRISTAL PERMITE LIGERAS IMPERFECCIONES ACEPTADAS POR NUESTRO CONTROL DE CALIDAD.

2

NOTA IMPORTANTE:
 Para corregir la torsión natural del cordón, frotar el cable con un destornillador o una varilla rígida, como indica la figura.

5

Para ver la ficha técnica de producto completa, puede usar el siguiente código QR:





ATTENTION: Schuller recommends to use included special screws when installing this pendant lamp.

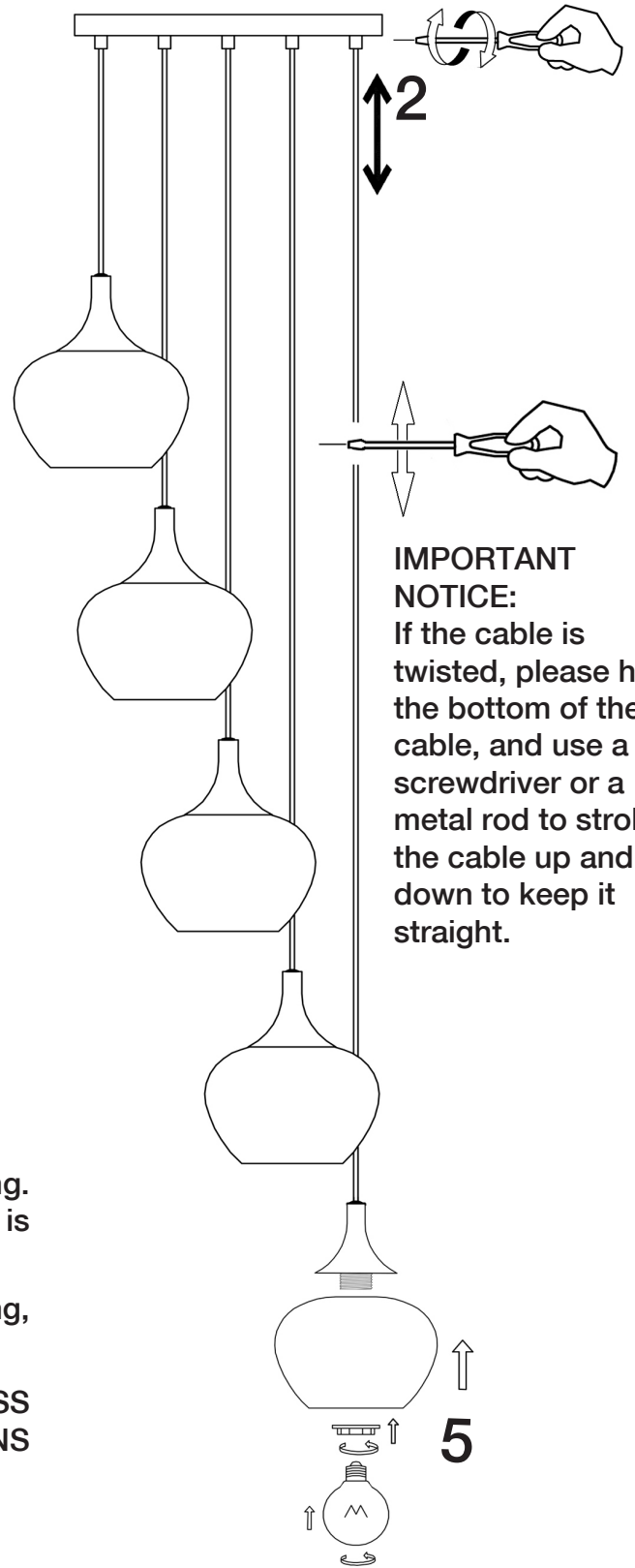
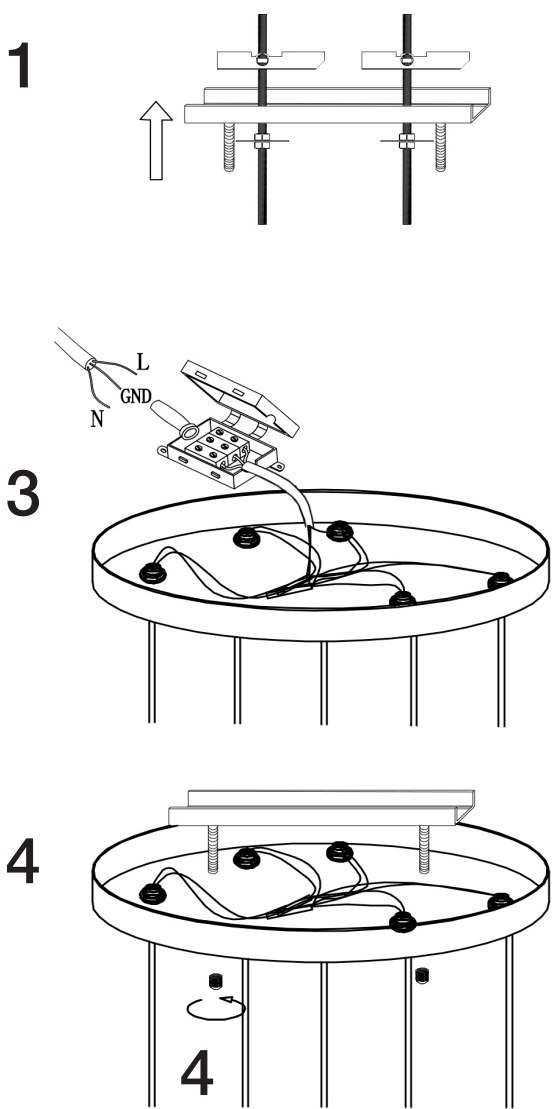

IMPORTANT NOTICE:
 If the cable is twisted, please hold the bottom of the cable, and use a screwdriver or a metal rod to stroke the cable up and down to keep it straight.

Adjust the length of the cables before installing.
 Place the glass shades once the lamp is installed in its final place.

During the handling (assembling, cleaning, etc) avoid that glasses knock each other.

CRAFTMAN PRODUCTION FOR THIS GLASS SHADE ALLOW SMALL IMPERFECTIONS CHECKED BY OUR QUALITY CONTROL

You may use the following QR code to view the complete technical data sheet of the product:

