

## Pars

Carlos Tícar



### EN

Its unique design makes it perfect for placing a series of different accessories at different heights; a reading lamp, a hook for hanging objects and trays of various sizes. Among the bedside tables which were created for this collection there is one which is incorporated in the head-board in the form of a small shelf. With all of these features, you can create your own original headboard and also personalize the sides of your bed.

### SP

Su particular diseño permite colocar a distintas alturas una serie de accesorios; un foco de lectura, un gancho para colgar objetos y bandejas de varios tamaños. Entre las mesitas de noche creadas para la colección hay una que se integra en el cabecero a modo de pequeña estantería. Con todas estas características, el usuario puede crear su propio y original cabecero, así como personalizar su lado de la cama.

### FR

La tête de lit Pars, est différente par rapport au modèles conventionnels, il s'agit d'un concept flexible, conçu comme une frise continue formée à partir de pièces verticales de plusieurs largeurs disponibles en plusieurs finitions laquées et en deux hauteurs, qui peuvent se combiner suivant votre choix pour obtenir des compositions symétriques ou asymétriques.

### DE

Das besondere Design erlaubt es auf unterschiedlichen Höhenstufen eine Reihe von verschiedenen Zubehörteilen anzubringen; eine Leselampe, ein Haken um Objekte verschiedenster Größe aufzuhängen. Zwischen den Nachttischen, die für diese Kollektion kreiert wurden, gibt es eine, die sich als kleines Regal in das Kopfteil integriert. All diese Merkmale erlauben es dem Benutzer, sein Bettkopfteil und seine Seite des Bettes so persönlich und individuell zu gestalten, wie er möchte.

### RU

Его особая конструкция позволяет размещать на разных высотах ряд аксессуаров; прожектор для чтения, крючок для подвешивания предметов и полок различных размеров. Среди тумбочек, созданных для этой коллекции, есть одна, которая интегрируется в изголовье как небольшая книжная полка. Со всеми этими функциями пользователь может создать свое собственное оригинальное изголовье, а также персонализировать свою сторону кровати.

## DIMENSIONS:

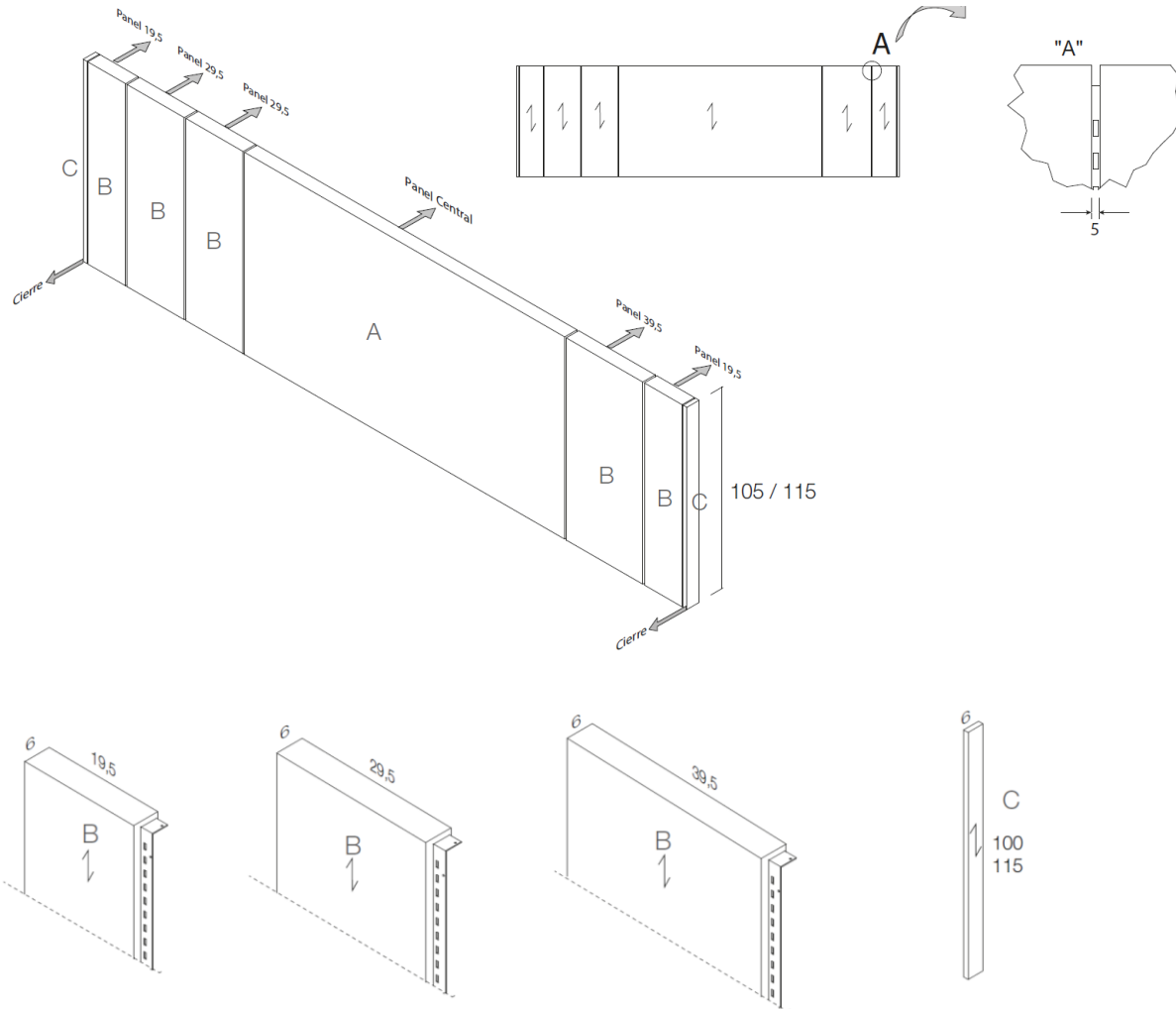

Cm	Inches	Panel / Panel / Panneaux / Pannel / Панель
19,5 x 100	7,68 x 39,37	B
19,5 x 115	7,68 x 45,28	B
29,5 x 100	11,61 x 39,37	B
29,5 x 115	11,61 x 45,28	B
39,5 x 100	15,55 x 39,37	B
39,5 x 115	15,55 x 45,28	B
6 x 100	2,36 x 39,37	C
6 x 115	2,36 x 45,28	C

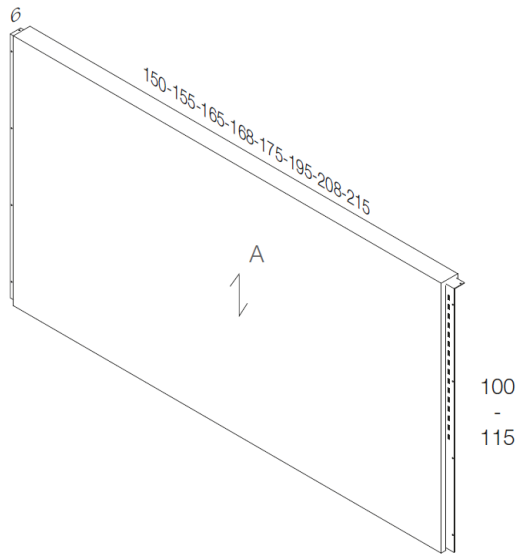

Pars headboard accessories / Complementos para cabezal Pars / Accessoires pour la tête de lit Pars / Zubehör für das Kopfteil / Аксессуары для изголовья

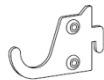
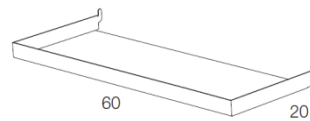
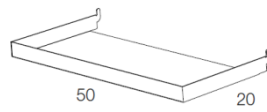
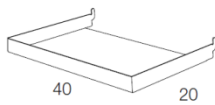
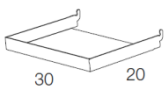
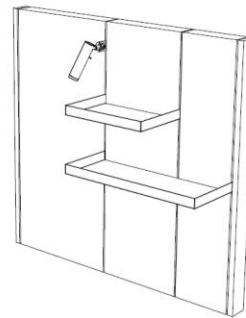
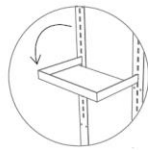
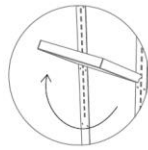
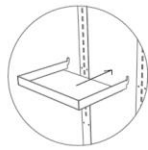
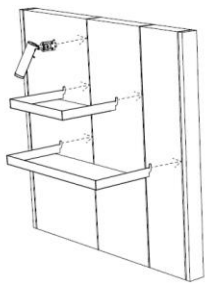

## FINISHES:

### Lacquers

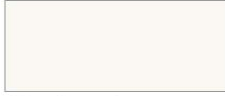

White / Blanco / Blanc

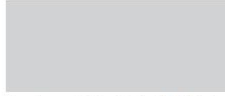

Pearl grey / Gris Perla / Gris Perle

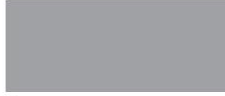

Foggy



Rain

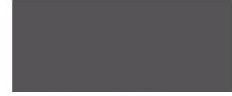

Slate / Pizarra / Ardoise



Stone / Piedra / Stone



Sahara



Mocca



Mink / Visón / Vison



Gold



Terracota / Terre Cuite



Brick



Merlot



Taupe



Black / Negro / Noir



Moss



Salvia



Whale blue / Azul Ballena / Bleu Baleine



Mustard / Mostaza / Moutarde



Navy



Coffee

### Natural Veneers



European oak / Roble europeo / Chêne Européen



Leopard oak / Roble Leopard / Chêne Leopard



American walnut / Nogal Americano / Noyer Américain



Smoky oak / Roble Fumé / Chêne Fumé

# Mobenia®

## Fabrics



Mine Kakhi



Mine Hunter



Mine Dolphin



Mine Anthracita



Libra 05



Libra 07



Libra 10



Libra 41



Libra 50



Libra 51



Libra 52



Libra 61

## DESIGNER:

Carlos Tiscar



### EN

Carlos Tiscar (1964) finished his studies in 1982 and he currently holds a degree in industrial design from the School of Applied Arts in Valencia, major in industrial design. Two years later, he moved to Italy and graduated from the Scuola Politecnica di Design di Milano. His professional career started in 1987 as a member of the industrial design group Factoria and, later on, as a partner of the consulting firm Gesto Design Management, in 1991.

In 1993, he founded his own studio, Tiscar Design, and his field of expertise is home, office and contract furniture, as well as urban furniture and homeware. Alongside with his studio, he has been a professor in several institutions and schools, such as Barreira (Valencia), AIMME (Paterna) and eset CEU (Alfara del Patriarca). Moreover, he's the former vicepresident of

### SP

Carlos Tiscar 1964. Miembro de ADCV. Aunque en realidad empezó a diseñar a los seis años de edad, tuvo que cursar estudios y graduarse en la Escuela de Artes Aplicadas de Valencia (1982), en la especialidad de Diseño Industrial. Dos años después, se trasladó a Italia para estudiar en la Scuola Politécnica di Design de Milán. Comenzó a dedicarse profesionalmente al diseño como miembro del grupo Factoría Diseño Industrial (1987) y como socio de Gesto Design Management (1991). Desde 1993 dirige su propio estudio.

Ha impartido la asignatura de proyectos para las siguientes escuelas e instituciones: Barreira (Valencia), AIMME (Paterna), eset CEU (Alfara del Patriarca) y EASD (Valencia). Fue presidente de la

### FR

Carlos Tiscar 1964, membre du ADCV. Même si en réalité il commence à faire du design à l'âge de 6 ans, il a du suivre des études et se diplômer en Design Industriel à l'Ecole des Beaux Arts de Valence (1982). Deux ans après il se déplace en Italie pour étudier à la Scuola Politécnica di Design à Milan. Il se consacre professionnellement au Design comme membre du Groupe Factoria Design Industrial (1987) et comme partenaire de Gesto Design Management (1991).

Depuis 1993 il dirige sa propre agence de design. Il assure la formation de projets pour les suivantes écoles et établissements: Barreira (Valence), AIMME (Paterna) eset CEU (Alfara del Patriarca) y EASD (Valence). Il a été Président de ADCV (Association de Designers de la communauté Valencienne) de 2012 à

### DE

Carlos Tiscar 1964. Mitglied im Verband der Designer der Autonomen Region von Valencia ADCV.

Obwohl er eigentlich schon im Alter von sechs Jahren mit dem Designen begann, musste er in der Schule für angewandte Kunst in Valencia im Fachbereich Industriedesign studieren und einen Abschluss machen (1982). Zwei Jahre später zog er nach Italien um in Mailand an der Polytechnischen Schule für Design (Scuola Politecnica di Design) zu studieren. Als Mitglied der Gruppe Factoría Diseño Industrial (1987) und als Partner von Gesto Design Management (1991) begann er sich professionell dem Design zu widmen.

Seit 1993 leitet er sein eigenes Studio. Er unterrichtete das Fach „Projekte“ an folgenden Schulen und Institutionen: Barreira (Valencia), AIMME (Paterna), eset CEU

### RU

Карлос Тискар, 1964. Член ADCV.

Он начал проектировать еще в возрасте шести лет, затем он учился и закончил школу прикладного искусства Валенсии (1982) по специальности Промышленный Дизайн. Два года спустя он переехал в Италию для учебы в Миланском политехническом университете. Он начал профессионально заниматься дизайном в качестве члена группы промышленного дизайна (1987) и в качестве партнера в Gesto Design Management (1991).

С 1993 года возглавляет собственную студию. Он преподавал проектирование для следующих школ и учреждений: Barreira (Валенсия), AIMME (Патерна), eset CEU (Альфара-дель-Патриарка) и EASD (Валенсия). Он был президентом ADCV (Ассоциация дизайнеров Валенсии) с 2012 по 2015 год. Его заслуги были отмечены, среди

the ADCV (the Designers of the Valencian Community Association)

ADCV (Asociación de Diseñadores de la Comunidad Valenciana) de 2012 a 2015. Su trabajo ha merecido, entre otros, el Premio Impiva, el Premio ADCV Oro, el Good Design Award, el German Design Award, y el iF Design Award.

2015. Son travail à remporté entre d' autres prix , le prix Impiva, le prix ADCV Or, le Good Design Award, Le German Design Award et le IF Design Award.

(Alfara del Patriarca) und EASD (Valencia). Von 2012 bis 2015 war er Präsident des ADCV (Verband der Designer der Autonomen Region von Valencia). Für seine Arbeiten erhielt er unter anderem den Impiva Award, den ADCV Gold Award, den Good Design Award, den German Design Award und den iF Design Award.

прочего, премией Impiva, золотой премией ADCV, Good Design Award, German Design Award и iF Design Award.