

REF. 4.022

F3201 Silla

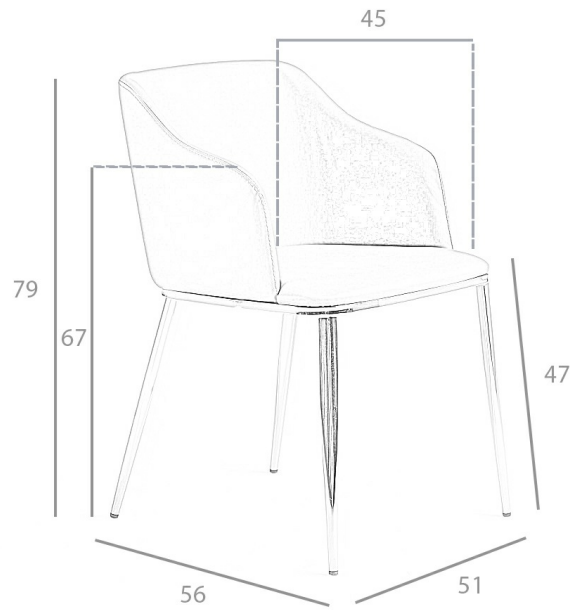

MEDIDAS

Medidas: 51 x 56 x 79 cm.

Peso: 7 Kg.

Metraje: 1,75 (x1,4) m.

EMBALAJE

66 x 50 x 70 cm. / 16 Kg.

VOLUMEN

0,15 m3

PRODUCTO

Polipiel - STOCK - Similar Acua 18

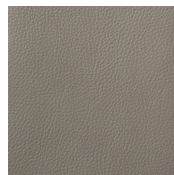

PATAS

Material Patas: Acero Cromado

