

**COSMOPOLITAN ● ROUND SUSPENSION**  
REF. 9980.100

**WEIGHT**

Net Weight: 33 kg | 72.8 lbs  
Gross Weight: 45 kg | 99.3 lbs

**BULBS**

Quantity: 24  
Type: G9  
Wattage: 40W (max)

**MATERIALS**

Body: Brass  
Details: Glass

**PACKING** (approx.)

Dimensions: 111 x 111 x 39 cm  
43.7 x 43.7 x 15.6 in  
Volume: 0.2 m<sup>3</sup> | 4.2 ft<sup>3</sup>

**HEIGHT**  
15 cm | 5.9 in

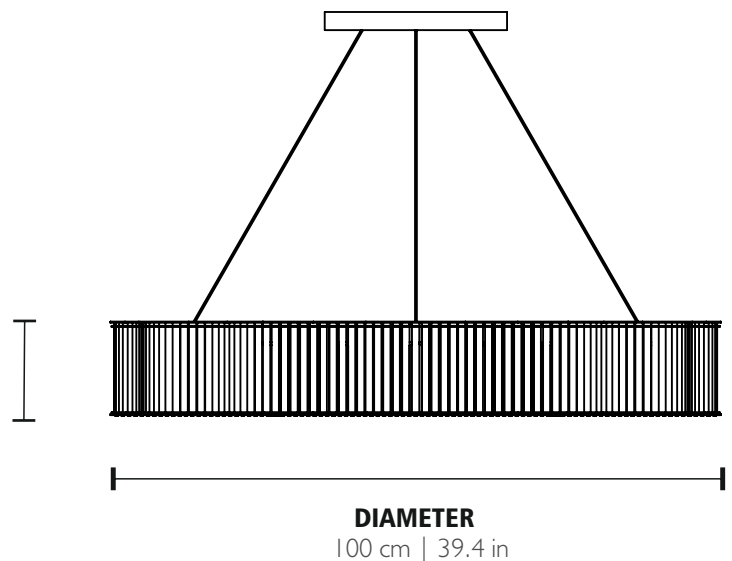

**DIAMETER**  
100 cm | 39.4 in

CE - Products manufactured according the European norm of security EN 60 598-1.

VF - Products adjusted for instalation in surfaces normally inflammable.

□ - Products of class II. The electric isolation is double or reinforced.

ES - Products with the possibility of instalation of low-energy consumption bulbs.

PRODUCT FINISHES & COSTUMIZATION OPTIONS

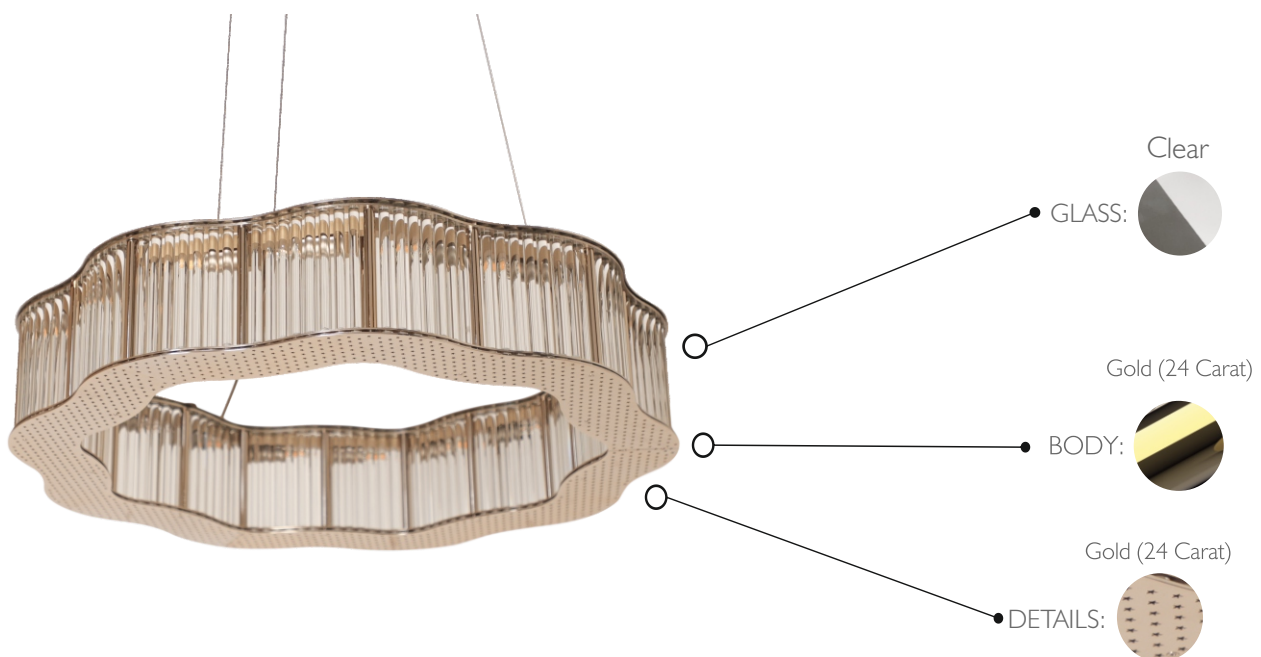

MORE FINISHES AVAILABLE HERE:

[CLICK HERE](#) 