

# Urban PF/60

Coming soon!

Diseño / Design:  
Joana Bover / 2011

Tipología: Plafón  
Typology: Ceiling lamp

Ambiente: Interior  
Environment: Indoor

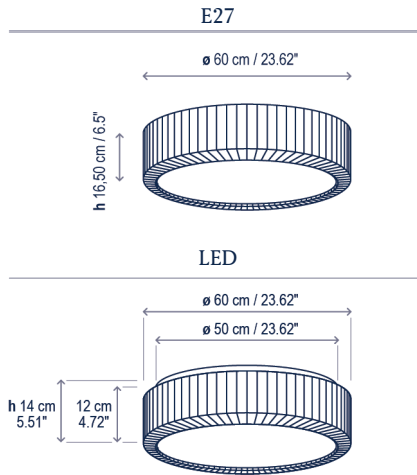

## Descripción técnica / Technical description:

Peso Neto: 6,27 kg  
Net Weight: 6,27 kg

1 Caja/Box | 67 x 67 x 25 cm | 0,1122 m<sup>3</sup>  
Peso bruto / Gross Weight: 8,22 kg

Materiales: Hierro  
Materials: Iron

Opciones Dali/1-10V: consultar  
Dali/1-10V options: consult

Difusor superior e inferior: Policarbonato  
Upper and lower diffuser: Polycarbonate

Hilo incandescente pantalla: 960°  
Shade GWFI: 960°

Personalizable  
Customizable

\*Bombillas no incluidas (E-27 P45)  
\*Bulbs not included (E-27 P45)

Regulable sólo si se utilizan bombillas regulables. / Dimmable only if dimmable bulbs are used.

\*\*Led para conexión directa a red eléctrica  
\*\*Led for direct connection to mains voltage

Certificaciones  
Certifications

Recambios / Spare parts:

R02325DIF Difusor / Diffuser

## Descripción lámpara / Lamps description:

230V 50HZ | IP-20 | 4 x MAX 9W LED E-27 P45 |

Ref	Acabados / Finishing	Ean13
*32502100189	Plata Mate - Pantalla Cinta Translúcida Blanca Matte Silver - White Translucent Ribbon Shade	8435493726083
*32502100190	Plata Mate - Pantalla Cinta Translúcida Crema Matte Silver - Cream Translucent Ribbon Shade	8435493726120

## Descripción lámpara / Lamps description:

230V 50HZ | IP-20 | TRIAC | 39 W LED / CRI: 90 / 2700K  
5400 lm fuente de luz / light source |

Ref	Acabados / Finishing	Ean13
32511105189	LED Regulable TRIAC Plata Mate - Pantalla Cinta Translúcida Blanca LED TRIAC Dimmable Matte Silver - White Translucent Ribbon Shade	8435493710136
32511105190	LED Regulable TRIAC Plata Mate - Pantalla Cinta Translúcida Crema LED TRIAC Dimmable Matte Silver - Cream Translucent Ribbon Shade	8435493710150

**bover**  
barcelona lights

Avda. Catalunya 173  
Poligon Ind. Sud  
08440 Cardedeu  
Barcelona, Spain

T. +34 938 713 152  
F. +34 938 462 089  
info@bover.es  
www.bover.es

Familia / Family: Urban

