

KENNETH COBONPUE
LIGHTING & ACCESSORIES





HALO and BIBA

KENNETHCOBONPUE



Welcome to the KENNETHCOBONPUE Lighting and Accessories Catalog.

Within these pages lies a world of whimsy, fun, and play to bring out the child in you. Inspired by ideas as diverse as our imagination takes us, our designers from around the world work with craftsmen to bring concepts to life. We use organic materials and environmentally friendly production processes, reflecting our concern for nature. Each unique piece is handmade and designed to bring wonder into your home.

The KENNETHCOBONPUE team is based in a small island in the Pacific called Cebu. We are blessed with lush landscape: radiant sun, clear seas, blue skies, and rolling mountains. It is a beautiful place to come home to after traveling through cosmopolitan centers of the world. Old traditions have survived here and the people convey a special warmth and friendliness. We collaborate with skilled craftsmen who take pride in their work. Many of the materials we use are sustainable, and we constantly strive to innovate their usage and extend their longevity. The specialized handwork that goes into each piece allows us to keep our energy consumption to a minimal.

At KENNETHCOBONPUE, we believe in the necessity of communing with nature and our fellow humans. We take our connection with nature and culture seriously. It is this feeling of being part of the world that we realize in our brand. It is our innate need to circulate around life, whether it be plants, animals, or other people.

Great expanse, openness,
lightness, familiarity
with the elements and seasons,
reminders of things past,
memories of people and places
that give us comfort,
awe, and wonder.

These emotions are evoked where we live.
We want to share these same emotions with you through our designs.

Kenneth Cobonpue



Cloud Collection

CONTENTS



Biba	01	Limbo	47
Carousel	03	Little People	53
Cloud	05	Luau	59
Constellation	07	Nori	61
Coral	09	Poppy	63
Crokkis	13	Safari	65
C U C Me	15	Shireen	67
Dragon's Tail	21	Shuttle	69
Fandango	23	Twiggy	71
Foglia	25	Village	73
Geisha	27	Whisk	75
Halo	29	Wiggle	77
Kai	33		
Kala	43	Designers	79
Kris Kros	45		

01 BIBA



ROUND MIRROR

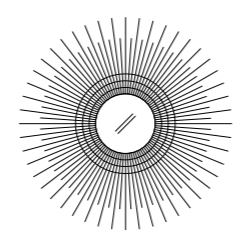
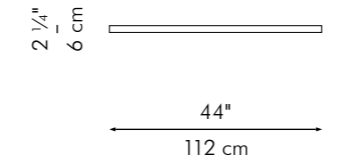

SMALL

mirror Ø (15 1/4" | 39 cm)
thickness (1/4" | 6 mm)

INDOOR rattan, powder-coated steel



Black / Orange / Yellow

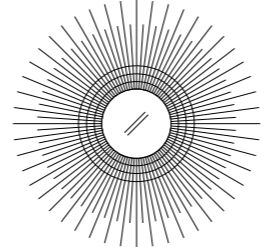
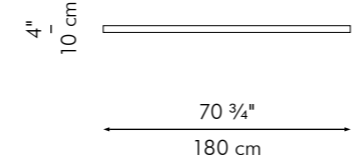

LARGE

mirror Ø (19 3/4" | 50 cm)
thickness (1/4" | 6 mm)

HANGING LAMP

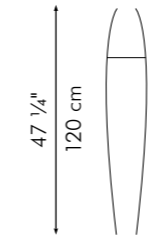
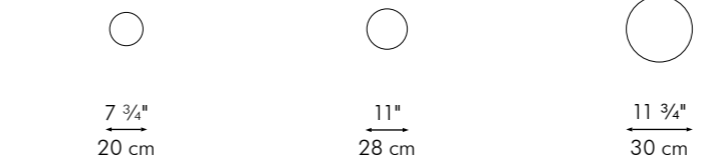

SMALL

Surface mounted pre-wired lamp
E26 / E27
110V - 230V

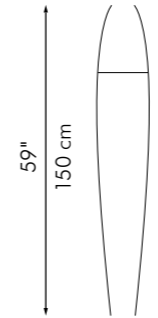

MEDIUM

INDOOR rattan, powder-coated steel, fiber-reinforced polymer



Black / Orange / Yellow

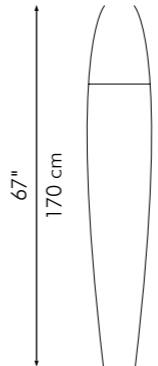

LARGE

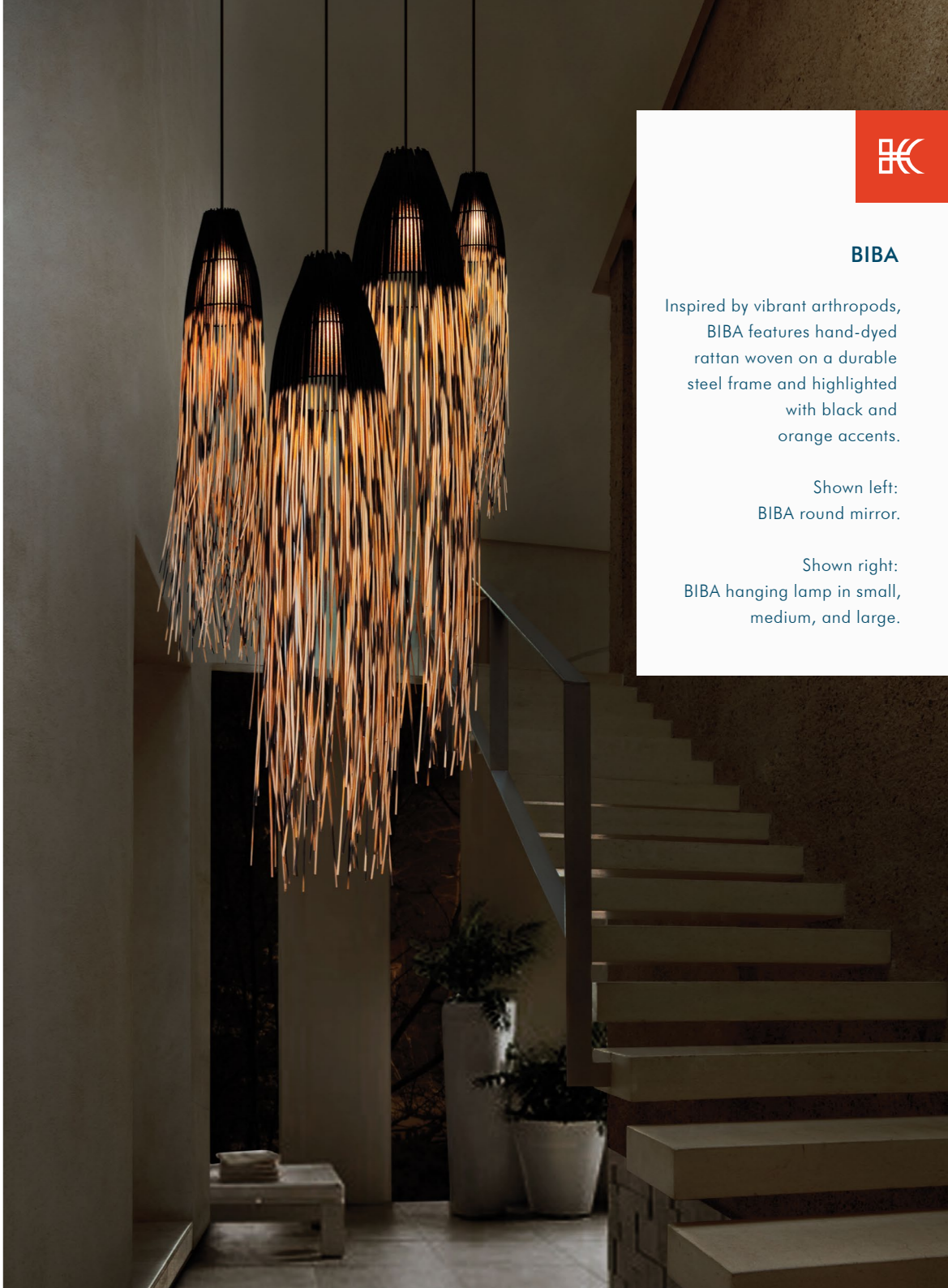

BIBA

Inspired by vibrant arthropods, BIBA features hand-dyed rattan woven on a durable steel frame and highlighted with black and orange accents.

Shown left: BIBA round mirror.

Shown right: BIBA hanging lamp in small, medium, and large.

03 CAROUSEL



HANGING LAMP

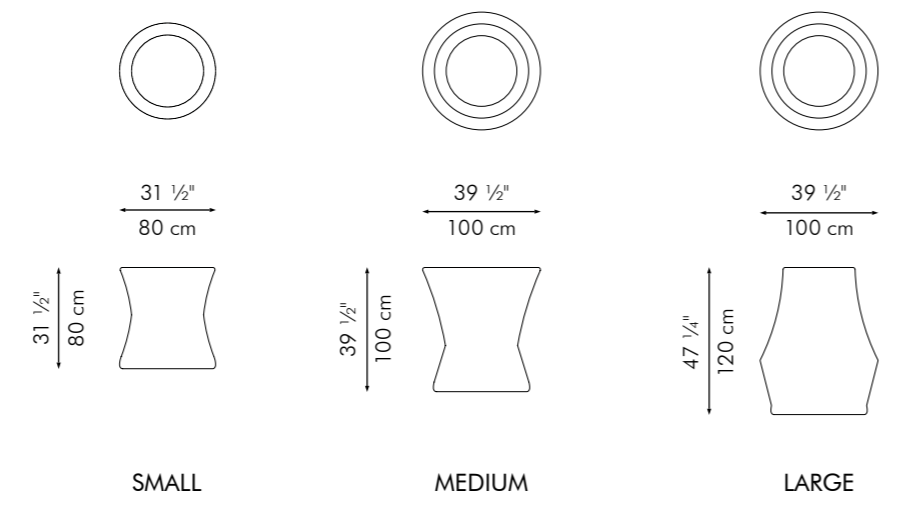

Surface mounted pre-wired lamp
 E26 / E27
 110V - 230V

INDOOR cotton rope, powder-coated steel

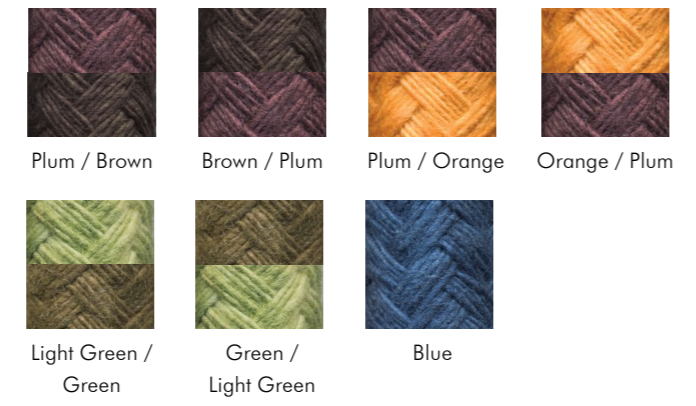

CAROUSEL

CAROUSEL evokes the wonder and whimsy of the world's grandest carnivals. Naturally dyed cotton rope is hand-knitted on hoops, creating a set of dramatic contemporary lighting pieces. Collapsible and packed flat.

Shown left: The CAROUSEL collection in various sizes and colors.

Shown right: CAROUSEL hanging lamps over the Tropez sofa and Kaja end tables.

05 CLOUD



HANGING LAMP

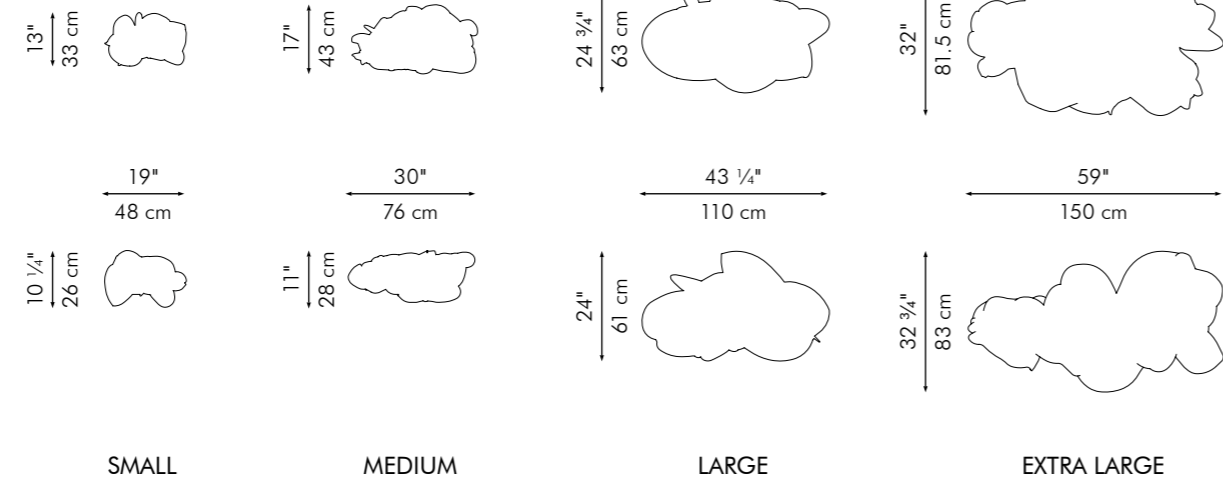

Surface mounted pre-wired lamp
E26 / E27
110V - 230V

INDOOR cotton, powder-coated steel

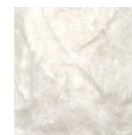

White



CLOUD

Thin cotton fiber is blown into shape by seemingly weightless wire armatures. The delicate forms are stronger than they appear and can be reshaped by hand.

by Hae Young Yoon

Shown right:
CLOUD hanging lamps over the Voyage bed.

07 **CONSTELLATION**



HANGING LAMP

CONSTELLATION 8

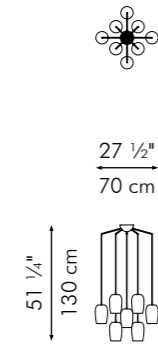

CONSTELLATION 16

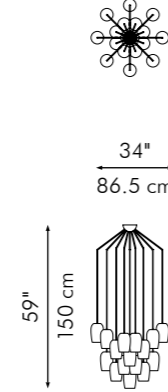

CONSTELLATION 24

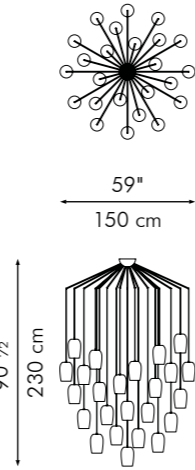

Surface mounted pre-wired lamp
E14
110V - 230V

INDOOR Buri (palm leaf spines), powder-coated steel, glass



Black



CONSTELLATION

Like the dazzling night sky, **CONSTELLATION** is a breathtaking formation of lines and pendulums. Glass lamps wrapped in woven Buri hang from the tips of steel rods and form orbits beneath the central base.

Shown left:
CONSTELLATION 16
hanging lamp.

Shown right:
CONSTELLATION 24 hanging
lamps over the
Yin & Yang sofa.

09 CORAL



TABLE DECOR

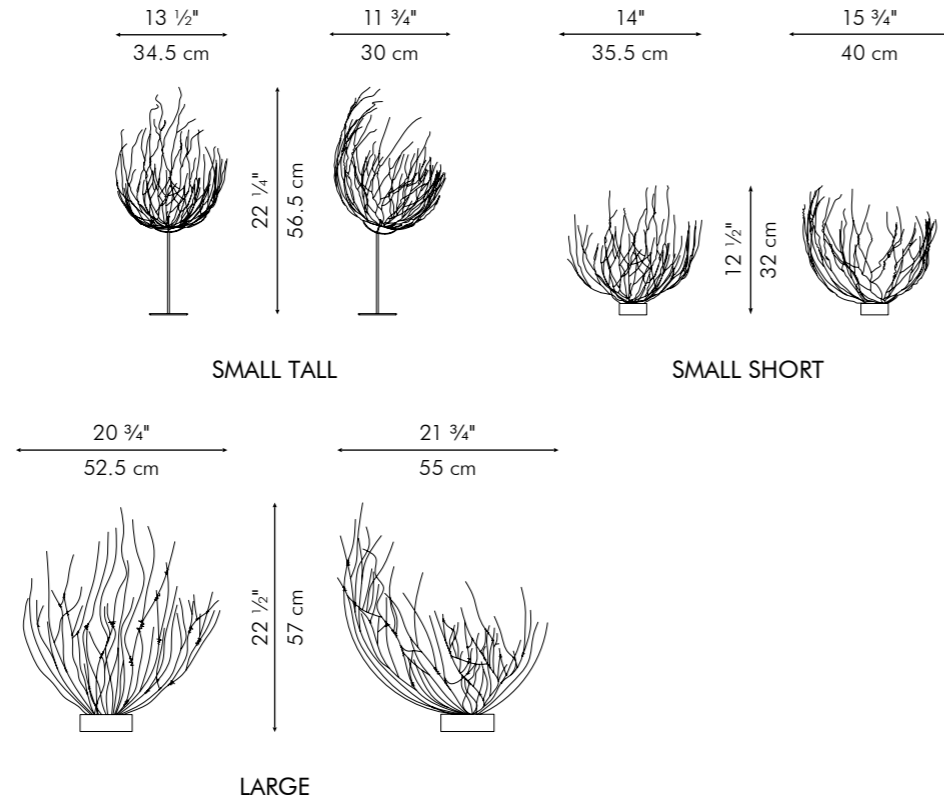

INDOOR Salago fiber, powder-coated steel



CORAL

Mimicking life beneath the ocean waters, the CORAL collection can brighten any room with its vibrant colors and organic forms. Made of Salago fiber and topped with stainless steel or copper, the pliable branches can be reshaped to express the flow of the tides.

Shown left: Detail of CORAL table decor in large.

Shown right: CORAL table decor in small tall and small short.

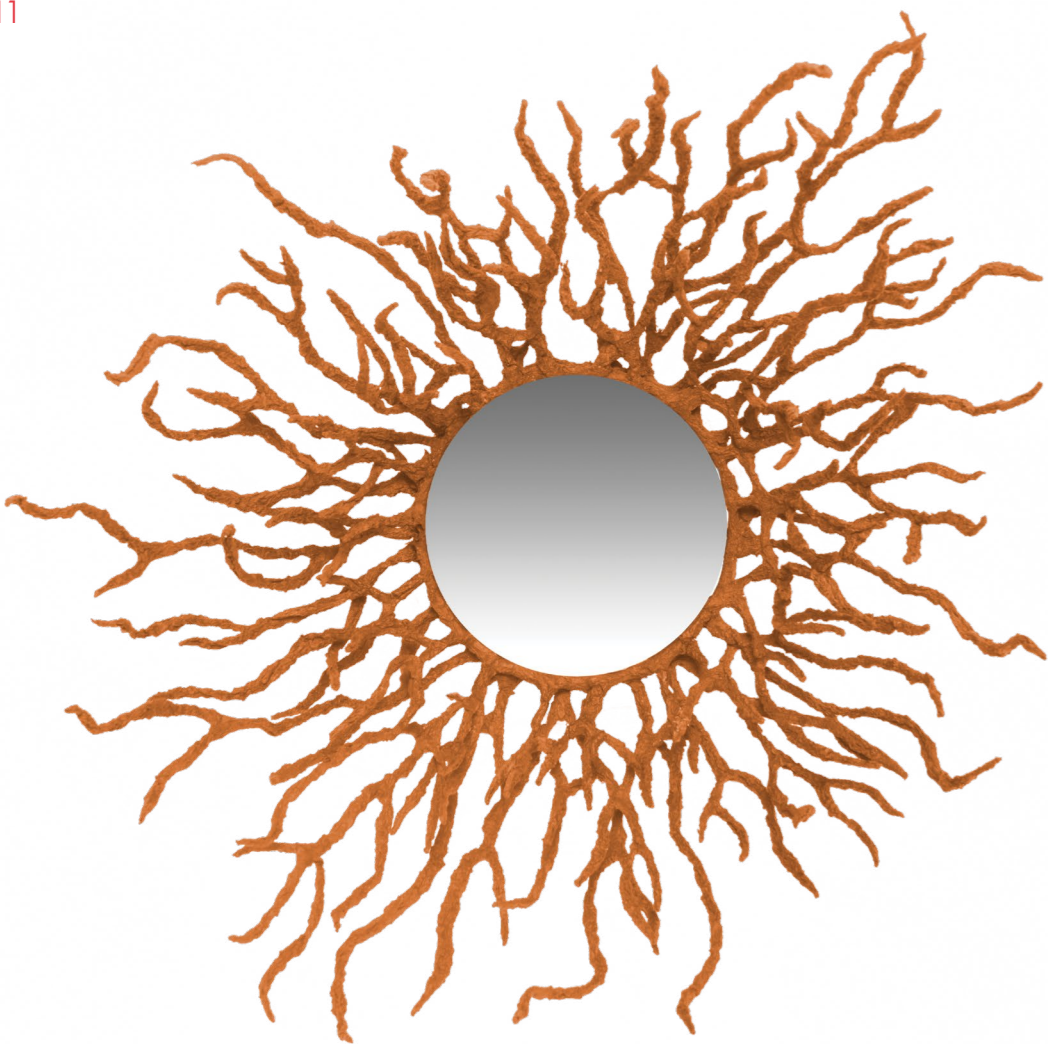

ROUND MIRROR

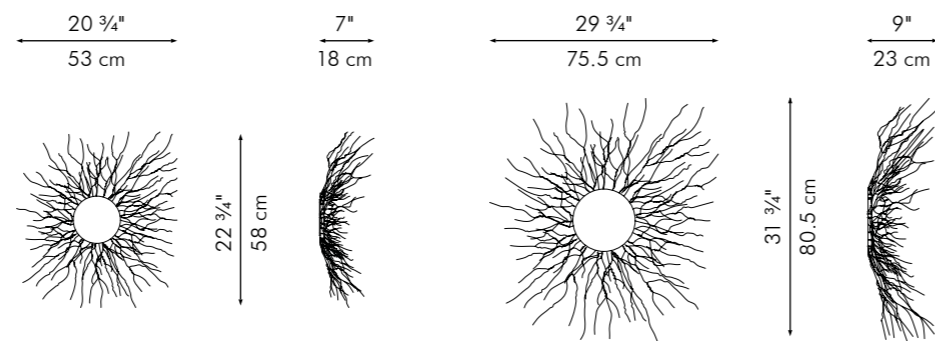

SMALL

LARGE

mirror Ø (6" | 15 cm)
thickness (1/4" | 6 mm)

mirror Ø (8" | 20 cm)
thickness (1/4" | 6 mm)

INDOOR Salago fiber, powder-coated steel



Terracotta Teal Green Silver



Black Brown Cream

WALL LAMP

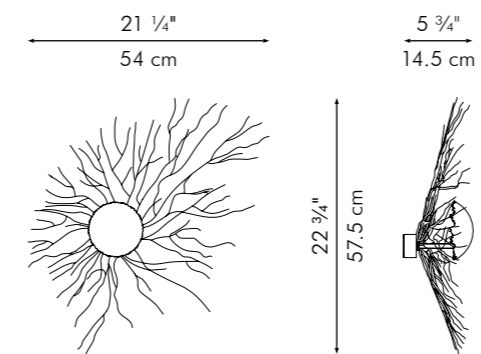

Portable mounted pre-wired lamp
G9
110V - 230V

INDOOR Salago fiber, powder-coated steel



Terracotta / Silver Teal / Copper Green / Copper Silver / Black



Black / Silver Brown / Copper Cream / Copper





13 CROKKIS

FLOOR VASE

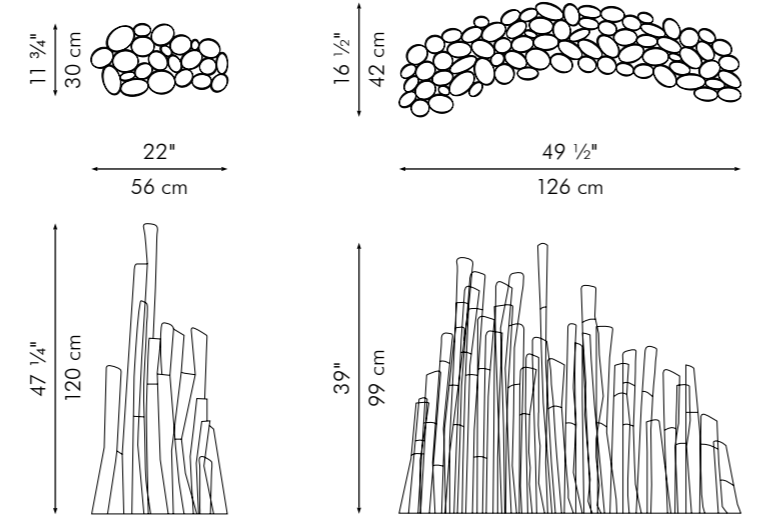

MEDIUM

LARGE

- glass tube sizes:**
- 1 pc. 1" Ø x 8" H (2.5 cm Ø x 20.3 cm H)
 - 1 pc. 1" Ø x 15" H (2.5 cm Ø x 38 cm H)
 - 1 pc. 1" Ø x 18 1/2" H (2.5 cm Ø x 47 cm H)
 - 1 pc. 1 1/2" Ø x 10" H (3.8 cm Ø x 25.4 cm H)
 - 1 pc. 1 1/2" Ø x 15" H (3.8 cm Ø x 38 cm H)
 - 3 pcs. 1 1/2" Ø x 18 1/2" H (3.8 cm Ø x 47 cm H)

- glass tube sizes:**
- 2 pcs. 1" Ø x 15" H (2.5 cm Ø x 38 cm H)
 - 3 pcs. 1" Ø x 18 1/2" H (2.5 cm Ø x 47 cm H)
 - 3 pcs. 1 1/2" Ø x 10" H (3.8 cm Ø x 25.4 cm H)
 - 2 pcs. 1 1/2" Ø x 15" H (3.8 cm Ø x 38 cm H)
 - 3 pcs. 1 1/2" Ø x 18 1/2" H (3.8 cm Ø x 47 cm H)

INDOOR glass tubes, powder-coated steel

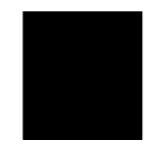

Black



CROKKIS

The CROKKIS collection interprets a freehand sketch into three dimensions, creating a sculptural form that functions as a vase. The various circles can host glass tubes—ideal containers for fresh flowers and other decorative elements.

Shown left: CROKKIS floor vase in medium.

Shown right: CROKKIS floor vase in large.

15 C U C M E



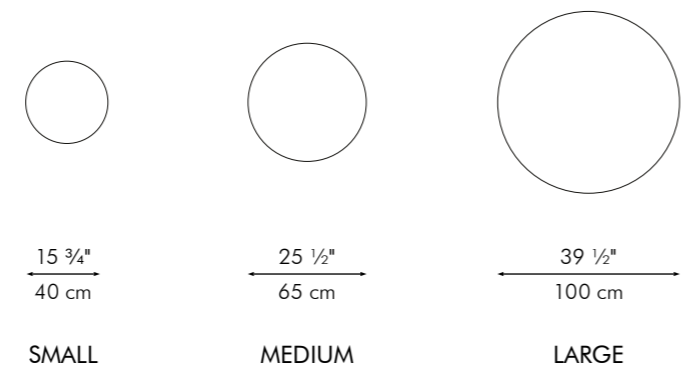

ROUND HANGING LAMP

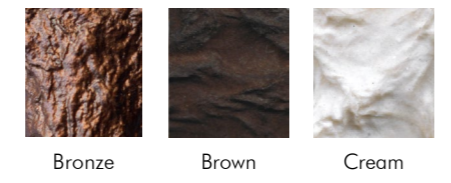

Surface mounted pre-wired lamp
E26 / E27
110V - 230V

INDOOR Salago fiber, powder-coated steel, fiber-reinforced polymer





C U C M E

The C U C M E collection plays with random translucent patterns framed within symmetrical boxes. Its wire frame is dipped into a vat of Salago fiber, forming interesting textures as it dries.

Shown left:
C U C M E hanging lamps in small, medium, and large.

Shown right:
C U C M E hanging lamp in medium.



FLOOR LAMP

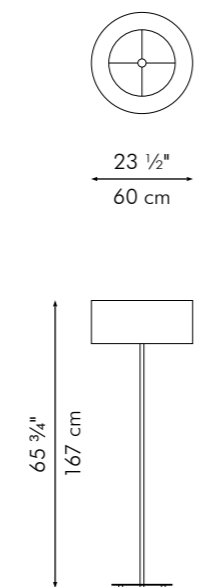

Portable pre-wired lamp
E26 / E27
110V - 230V

HANGING LAMP

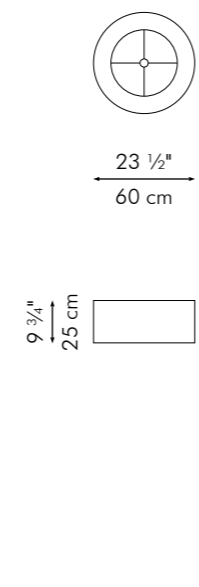

Surface mounted pre-wired lamp
E26 / E27
110V - 230V

INDOOR Salago fiber, powder-coated steel, handmade paper, Mylar

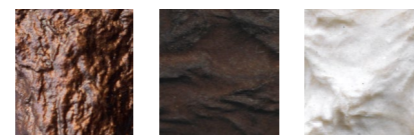

Bronze Brown Cream

MIRROR RECTANGULAR

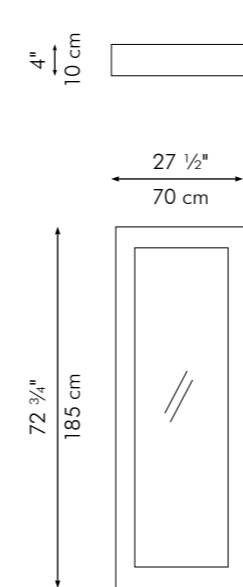

mirror size (19 1/2" W x 65" H)
(50 cm W x 164.8 cm H)
thickness (1/4" | 6 mm)

INDOOR Salago fiber, powder-coated steel, mirror glass

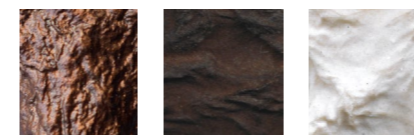

Bronze Brown Cream

MIRROR ROUND

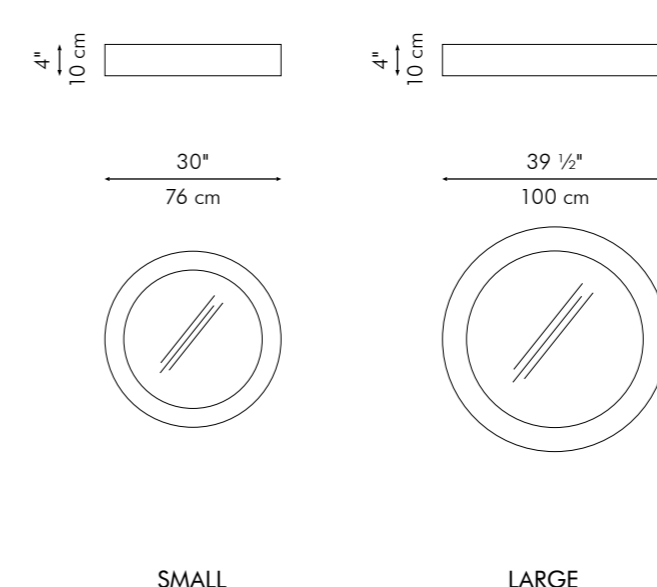

SMALL
mirror Ø (20" | 50.6 cm)
thickness (1/4" | 6 mm)

LARGE
mirror Ø (31 1/2" | 80 cm)
thickness (1/4" | 6 mm)





O FLOOR LAMP



9 3/4"
25 cm



9 3/4"
25 cm

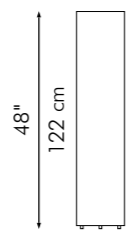

MEDIUM

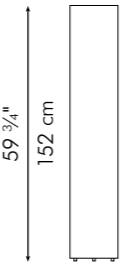

LARGE

Portable pre-wired lamp
E26 / E27
110V - 230V

INDOOR Salago fiber, powder-coated steel, handmade paper, Mylar



Bronze

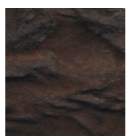

Brown



Cream

SCREEN



23 3/4"
60.5 cm



23 3/4"
60.5 cm



23 3/4"
60.5 cm

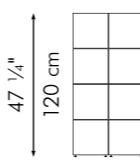

SMALL

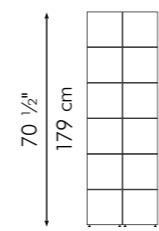

MEDIUM

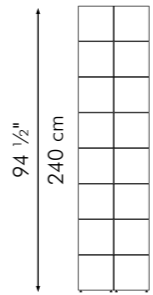

LARGE

INDOOR Salago fiber, powder-coated steel

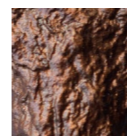

Bronze

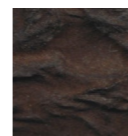

Brown



Cream



21 DRAGON'S TAIL



TABLE LAMP

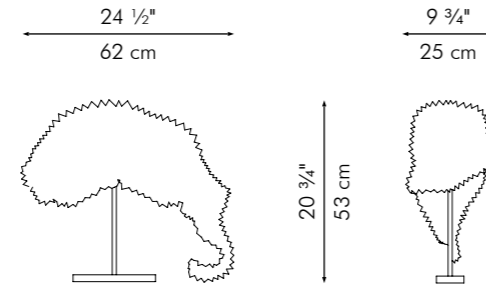

Portable pre-wired lamp
E26 / E27
110V - 230V

INDOOR specialty paper, stainless steel



Cream



DRAGON'S TAIL

Inspired by childhood tales, the DRAGON'S TAIL lamp transforms the auspicious power of dragons into a unique lighting creation. Using the Japanese art of Origami, hand-folded paper sections are attached to each other to create a tail-like form.

by Luisa Robinson

Shown left:
Detail of DRAGON'S TAIL
table lamp.

Shown right:
DRAGON'S TAIL table lamp.

23 FANDANGO



HANGING LAMP



29 1/2"
75 cm



15 3/4"
40 cm

SMALL

Surface mounted pre-wired lamp
G9
110V - 230V



39 1/2"
100 cm



25 1/2"
65 cm

MEDIUM

LED Chip Version
ANSI
110V / 12-48VDC

IEC/CENELEC
230V / 12-48VDC

INDOOR cotton fiber, powder-coated steel



White



FANDANGO

FANDANGO captures the power and expression of a Flamenco dancer twirling in space. Petals of cotton fabric are shaped to diffuse light and portray the drama of dancing in the wind.

by Danny Fang

Shown left:
Detail of FANDANGO
hanging lamp.

Shown right:
FANDANGO hanging lamp
in medium over the Parchment
collection and Gobi tables.



HANGING LAMP

PALMA

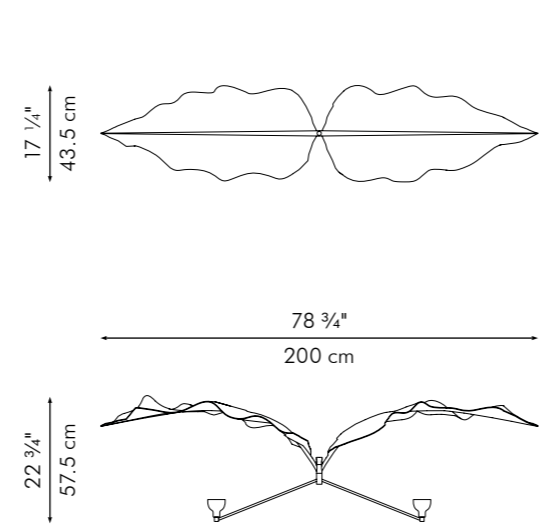

Surface mounted pre-wired lamp
GU10
110V - 230V

INDOOR fiber-reinforced polymer, brass



CALLA

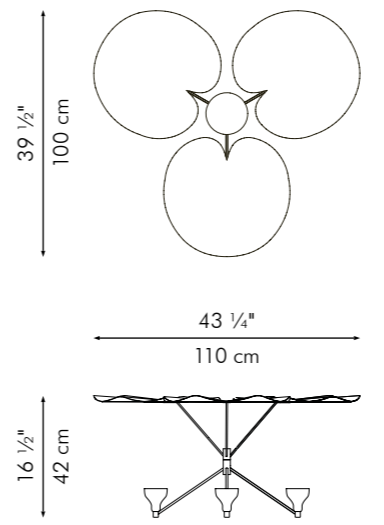

Surface mounted pre-wired lamp
GU10
110V - 230V

INDOOR fiber-reinforced polymer, brass

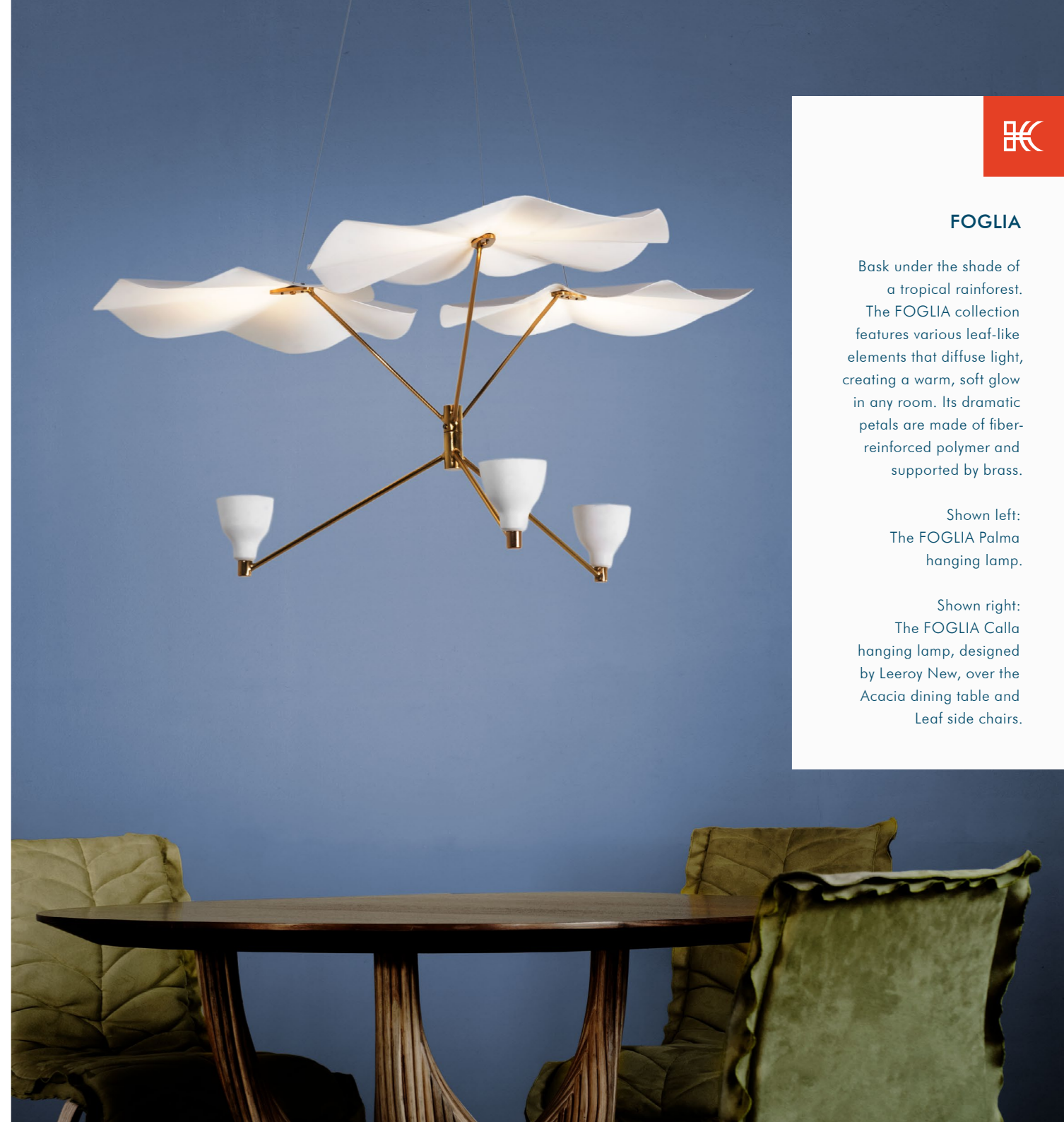

FOGLIA

Bask under the shade of a tropical rainforest. The FOGLIA collection features various leaf-like elements that diffuse light, creating a warm, soft glow in any room. Its dramatic petals are made of fiber-reinforced polymer and supported by brass.

Shown left: The FOGLIA Palma hanging lamp.

Shown right: The FOGLIA Calla hanging lamp, designed by Leeroy New, over the Acacia dining table and Leaf side chairs.

27 **GEISHA**



FLOOR LAMP

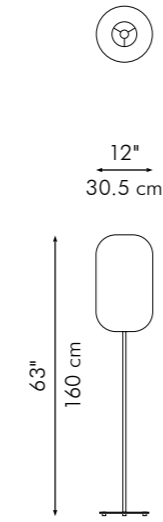

Portable pre-wired lamp
E26 / E27
110V - 230V

INDOOR rattan, powder-coated steel, handmade paper, Mylar

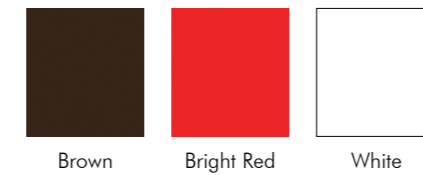
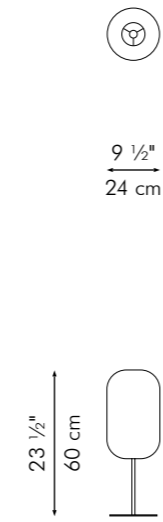
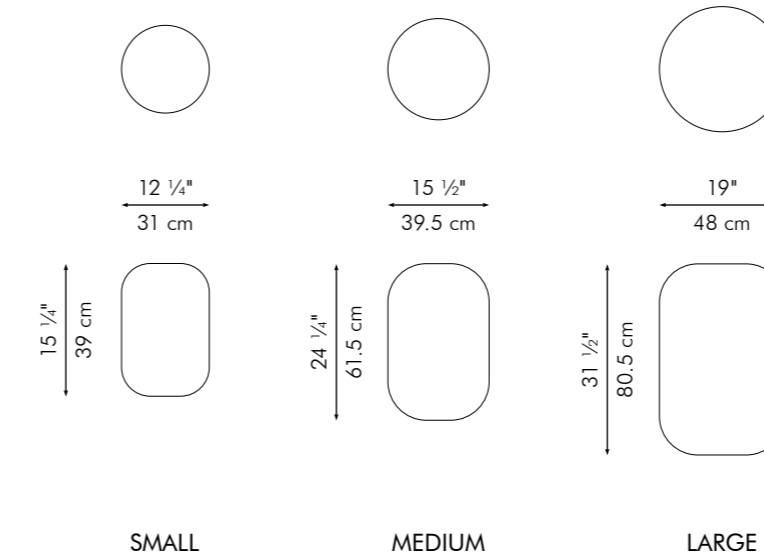

TABLE LAMP



LANTERN



Surface mounted pre-wired lamp
E26 / E27
110V - 230V

INDOOR rattan, powder-coated steel, handmade paper, Mylar

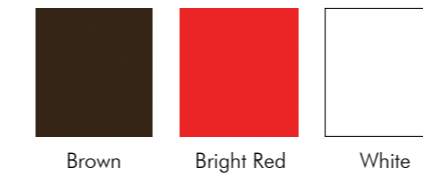

GEISHA

The GEISHA lamp is a modern interpretation of the traditional hanging lanterns that lit Kyoto's temples, houses, and inns. Rattan is woven over a metal frame laminated with Mylar to diffuse light and create an intimate atmosphere.

by Christy Manguerra

Shown left:
GEISHA floor and table lamp
with the Freya writing desk
and Parchment armchair.

Shown right:
GEISHA lanterns in small,
medium, and large.



29 HALO

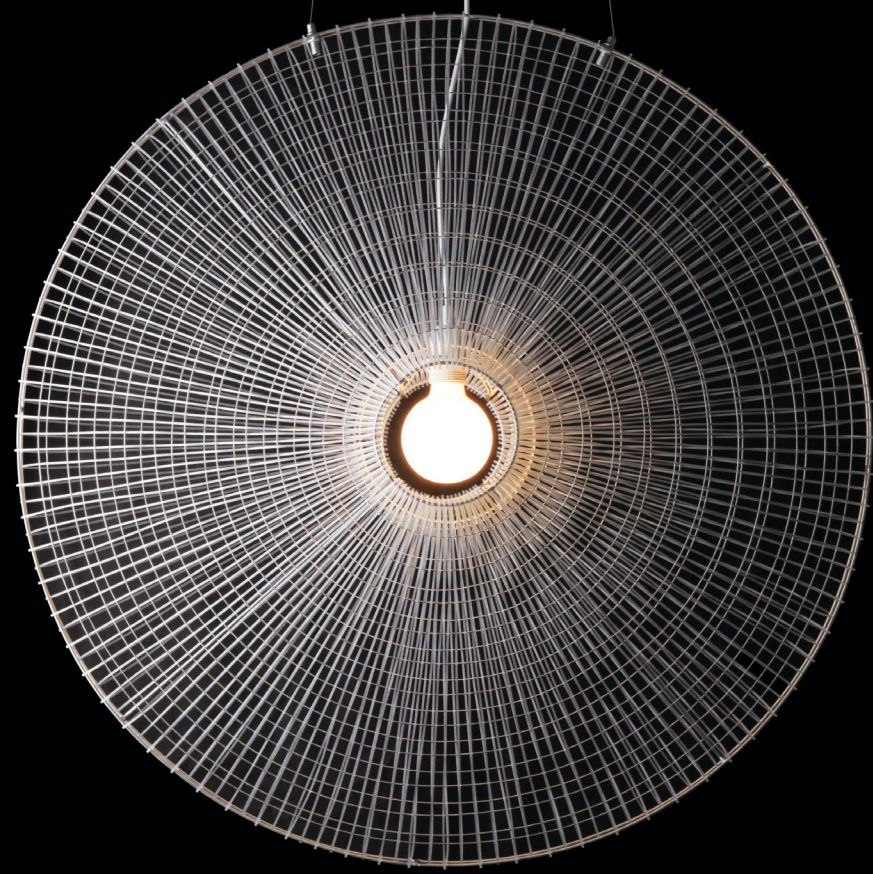

PENDANT LAMP

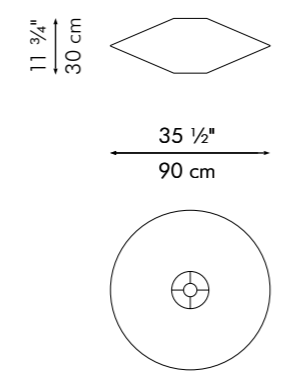

Surface mounted pre-wired lamp
E26 / E27
110V - 230V

INDOOR nylon, powder-coated steel



TRIPOD LAMP

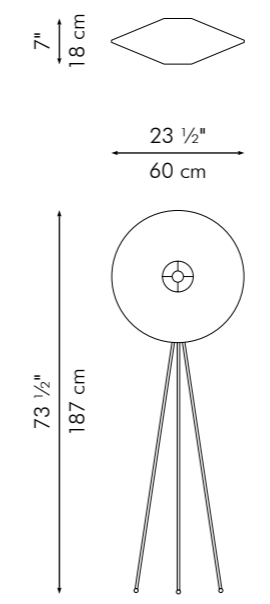

Portable pre-wired lamp
E26 / E27
110V - 230V

INDOOR nylon, powder-coated steel

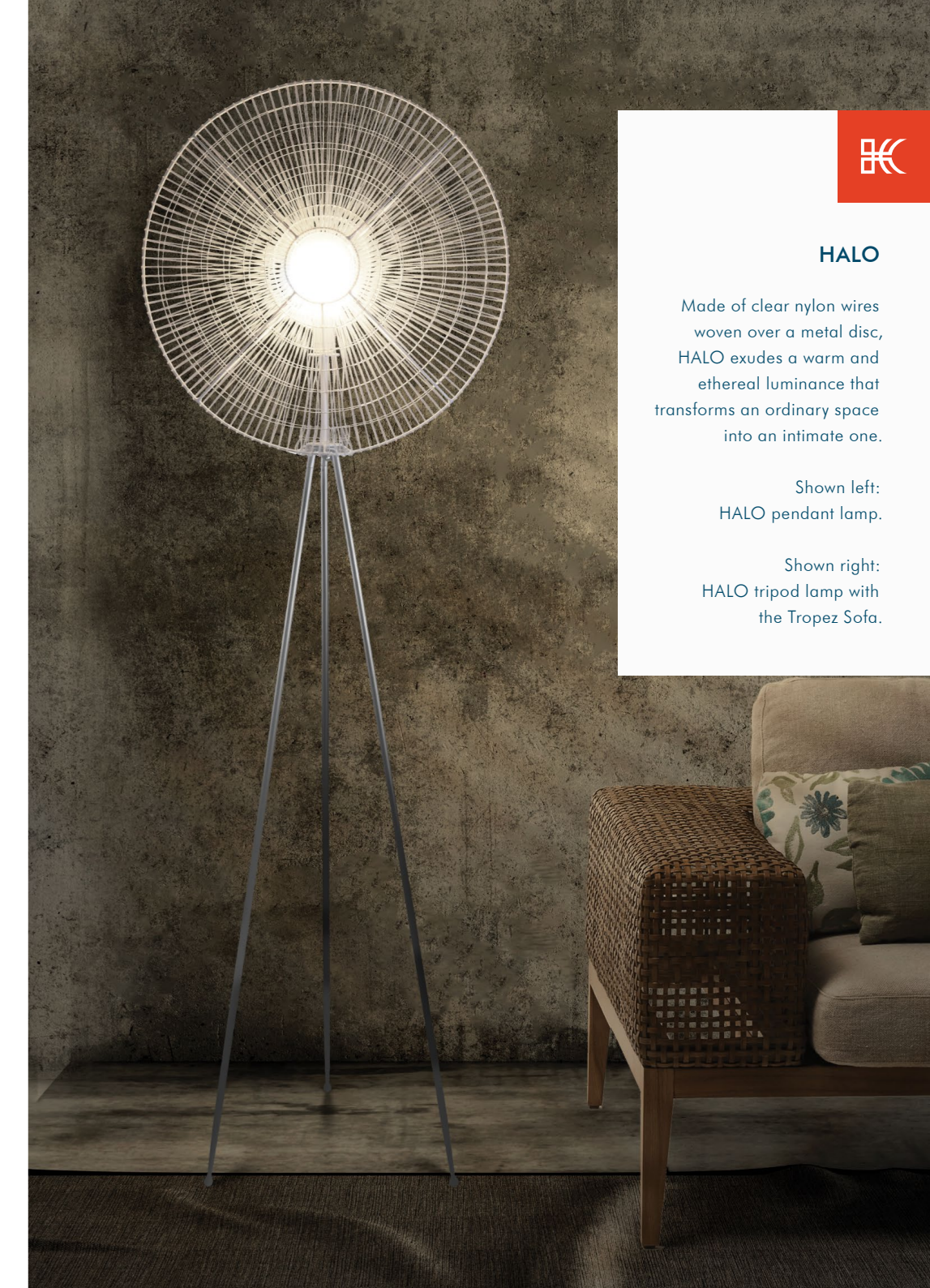
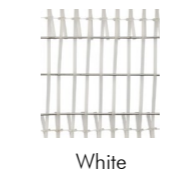

HALO

Made of clear nylon wires woven over a metal disc, HALO exudes a warm and ethereal luminance that transforms an ordinary space into an intimate one.

Shown left:
HALO pendant lamp.

Shown right:
HALO tripod lamp with
the Tropez Sofa.

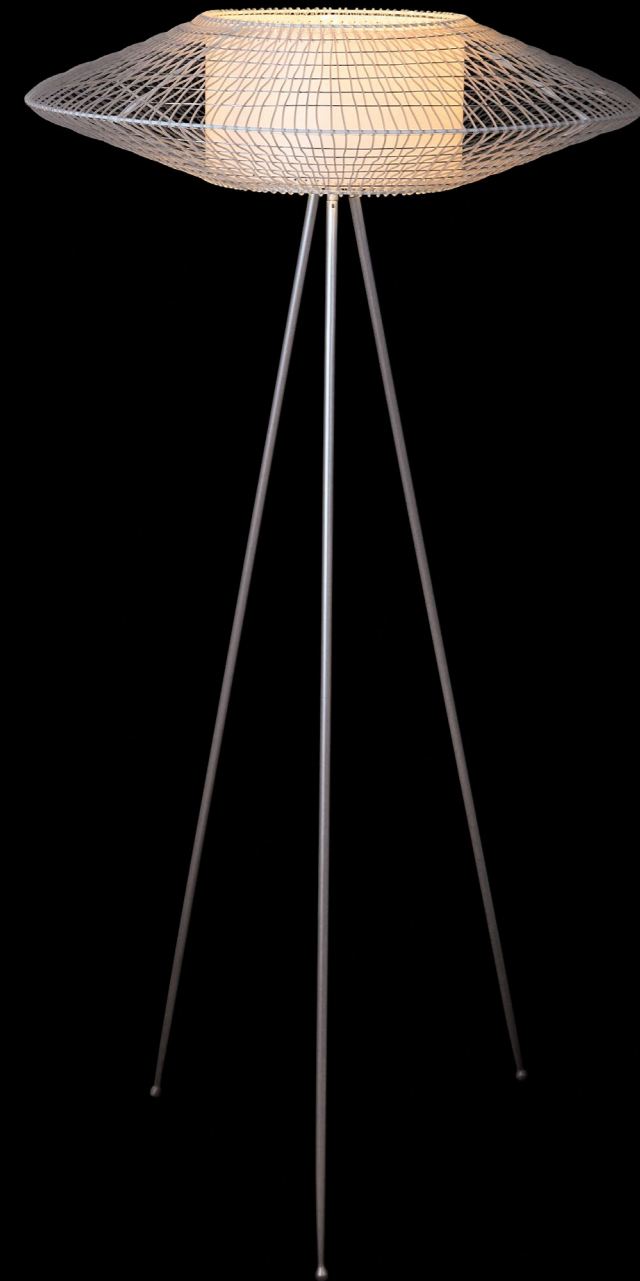

DISK TRIPOD LAMP

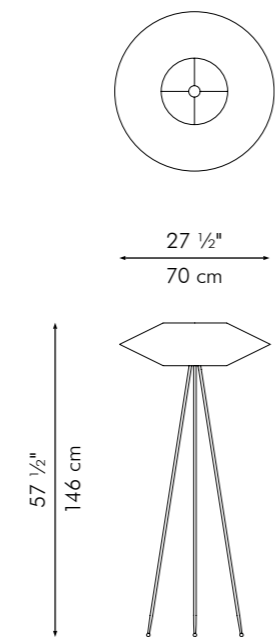

Portable pre-wired lamp
E26 / E27
110V - 230V

INDOOR nylon, powder-coated steel, handmade paper, Mylar



White

DISK LAMP

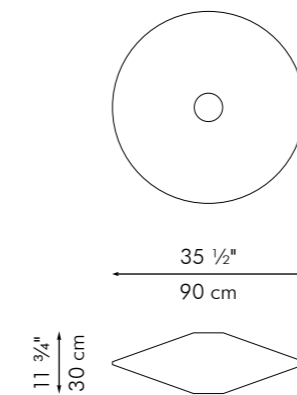

Surface mounted pre-wired lamp
E26 / E27
110V - 230V

INDOOR nylon, powder-coated steel



White





33 KAI

ARC LAMP

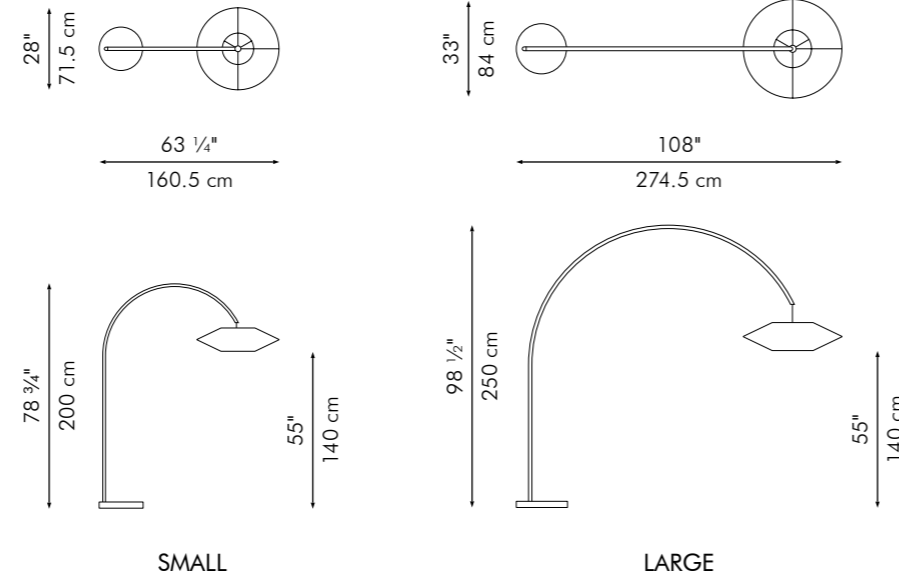

Portable pre-wired lamp
E26 / E27
110V - 230V

INDOOR Buri (palm leaf spines), powder-coated steel, handmade paper, Mylar



Brown



KAI

Let the warm light of the KAI collection lead you home. Buri woven over a light steel frame in a linear pattern creates a strong contrast against a handmade paper diffuser.

Shown left: Detail of the KAI arc lamp.

Shown right: KAI arc lamp large with the Croissant collection.



HANGING LAMP RECTANGULAR

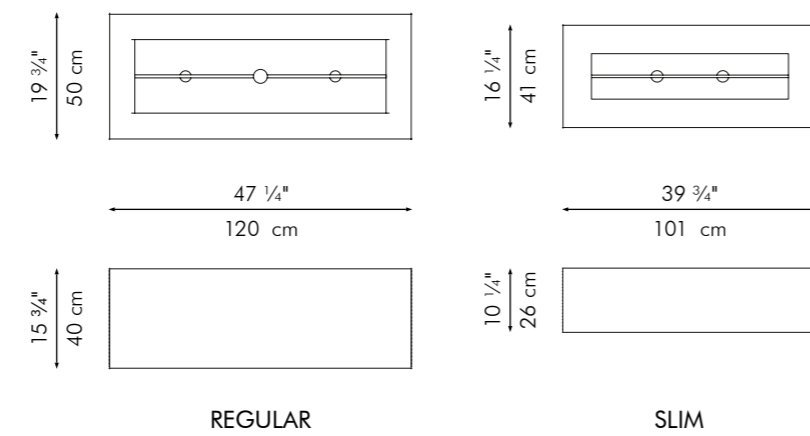

Surface mounted pre-wired lamp
E26 / E27
110V - 230V

INDOOR Buri (palm leaf spines), powder-coated steel, handmade paper, Mylar



Brown





LANTERN

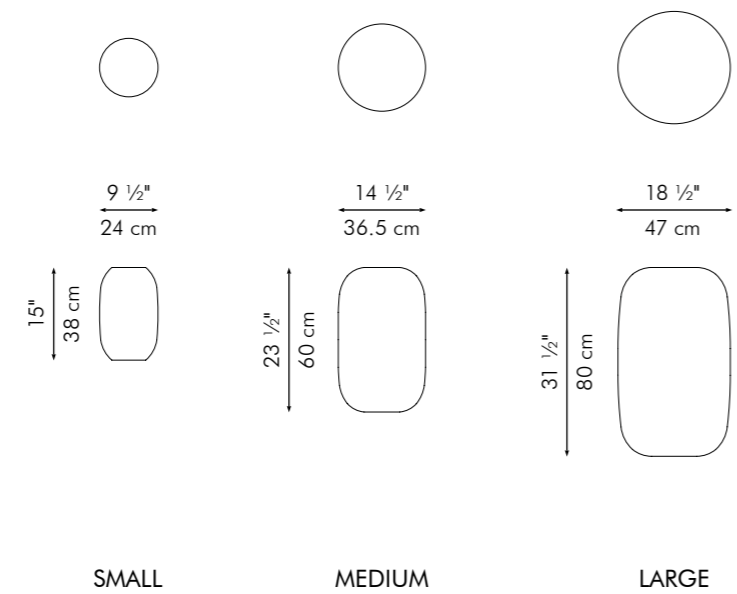

Surface mounted pre-wired lamp
E26 / E27
110V - 230V

INDOOR Buri (palm leaf spines), powder-coated steel, handmade paper, Mylar



Brown

TRIPOD LAMP

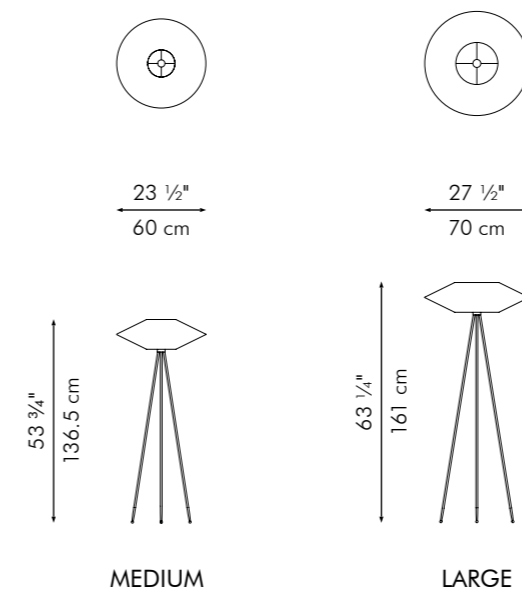

Portable pre-wired lamp
E26 / E27
110V - 230V

INDOOR Buri (palm leaf spines), powder-coated steel, handmade paper, Mylar



Brown



KAI HARA
HANGING LAMP

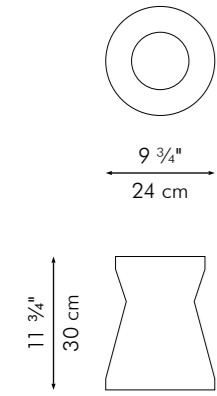

Surface mounted pre-wired lamp
E26 / E27
110V - 230V

INDOOR Buri (palm leaf spines), powder-coated steel, handmade paper, Mylar



Brown

KAI O
TABLE LAMP

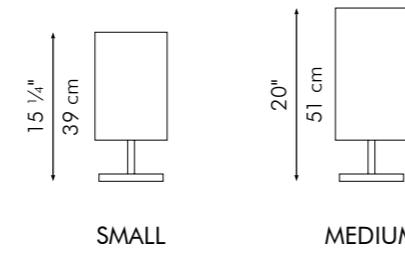
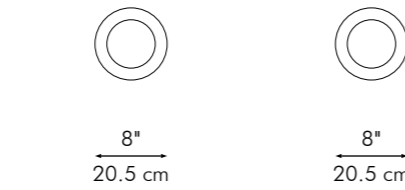

Portable pre-wired lamp
E26 / E27
110V - 230V

INDOOR Buri (palm leaf spines), powder-coated steel, handmade paper, Mylar



Brown



KAI O
FLOOR LAMP

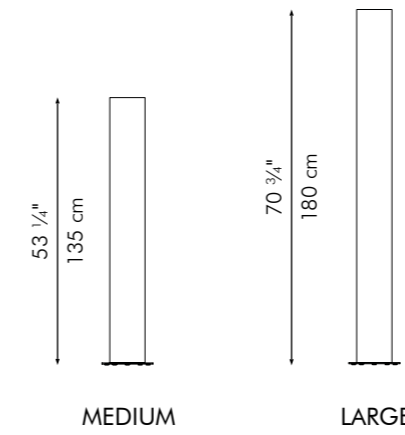
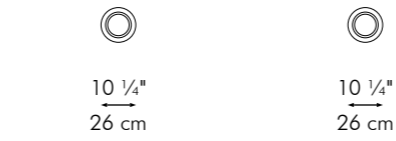

Portable pre-wired lamp
E26 / E27
110V - 230V

INDOOR Buri (palm leaf spines), powder-coated steel, handmade paper, Mylar



Brown





KAI O HANGING LAMP

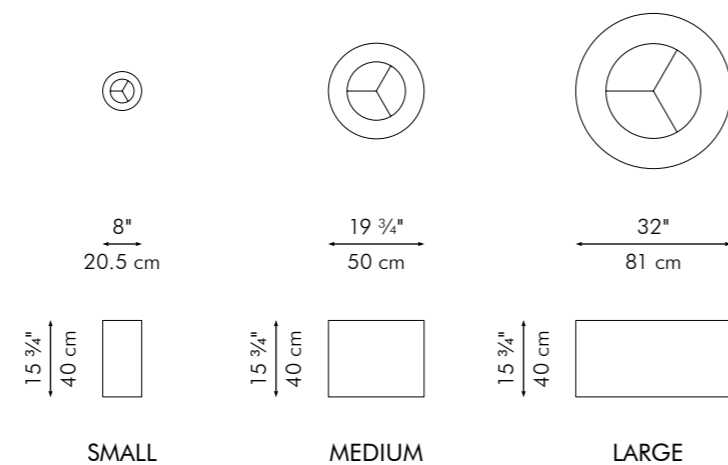

Surface mounted pre-wired lamp
E26 / E27
110V - 230V

INDOOR Buri (palm leaf spines), powder-coated steel, handmade paper, Mylar



Brown

KAI Z FLOOR LAMP

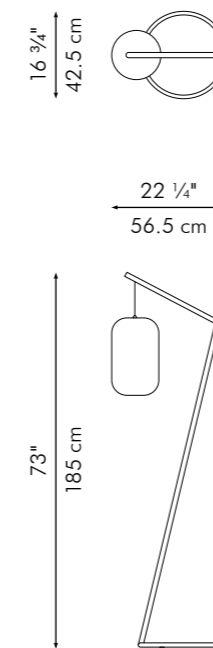

Portable pre-wired lamp
E26 / E27
110V - 230V

INDOOR Buri (palm leaf spines), powder-coated steel, handmade paper, Mylar



Brown





VASE

 $5 \frac{3}{4}''$
14.5 cm

 $3 \frac{3}{4}''$
9.5 cm

 $6 \frac{1}{2}''$
16.5 cm

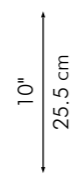
 $3 \frac{3}{4}''$
9.5 cm

SMALL

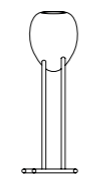
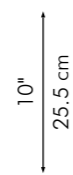

LARGE

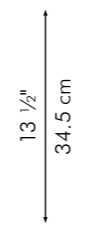

INDOOR fiber-reinforced polymer, powder-coated steel



Pale Gray



Dark Gray



KALA

Tenacious and often elusive
are the birds of the wild.
The KALA vase is easier to find
on your tabletop with its
elegant stride and plumage.
Sold in pairs.

Shown left:
Small KALA vases in dark gray.

Shown right:
Large and small KALA vases
in pale and dark gray on the
Pebble coffee table with
the Parchment Collection.



45 KRIS KROS

WALL LAMP

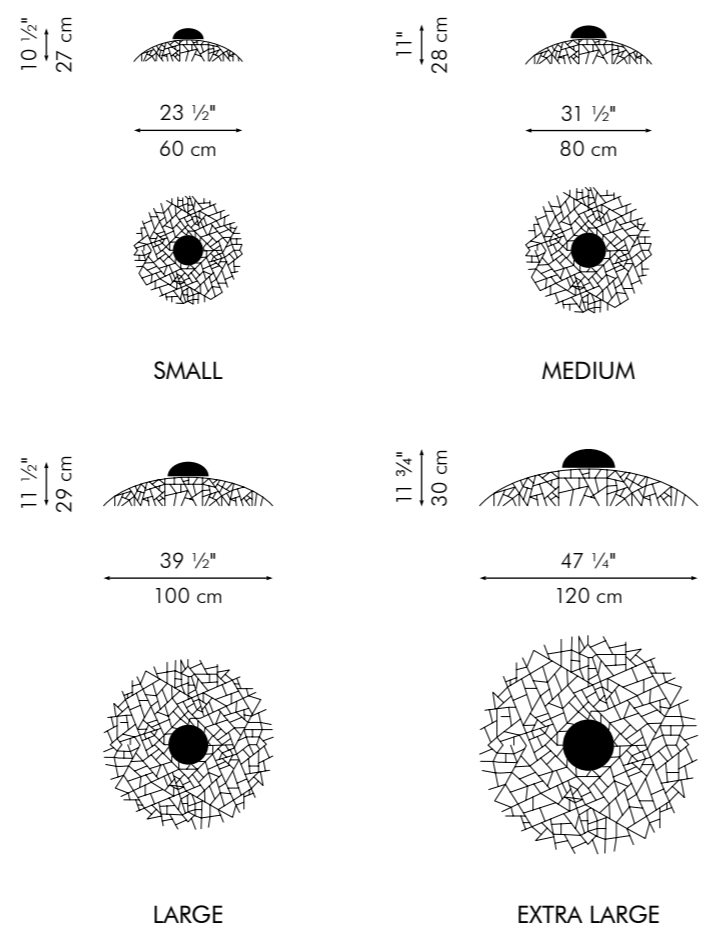

Surface mounted pre-wired lamp
E26 / E27
110V - 230V

INDOOR bamboo twigs, powder-coated steel

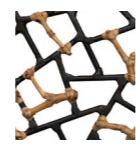

Black

HANGING LAMP

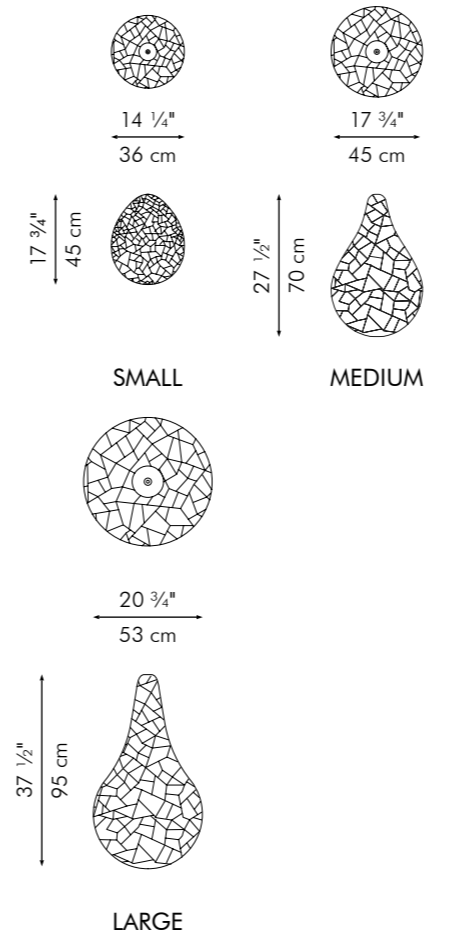

Surface mounted pre-wired lamp
E26 / E27
110V - 230V

INDOOR bamboo twigs, powder-coated steel



Black

SCREEN

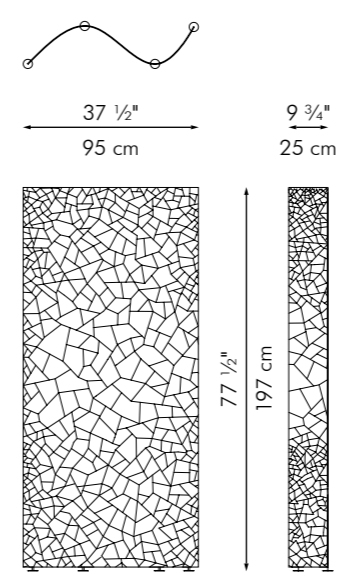

INDOOR bamboo twigs, powder-coated steel

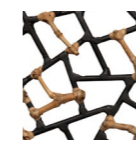

Black



KRIS KROS

Made from a series of branching bamboo twigs tied to a geometric latticework of steel, KRIS KROS is a play of forms resembling cocoons and organic screens.

Shown left:
KRIS KROS wall lamps
in various sizes.

Shown right:
KRIS KROS hanging lamp
in large.

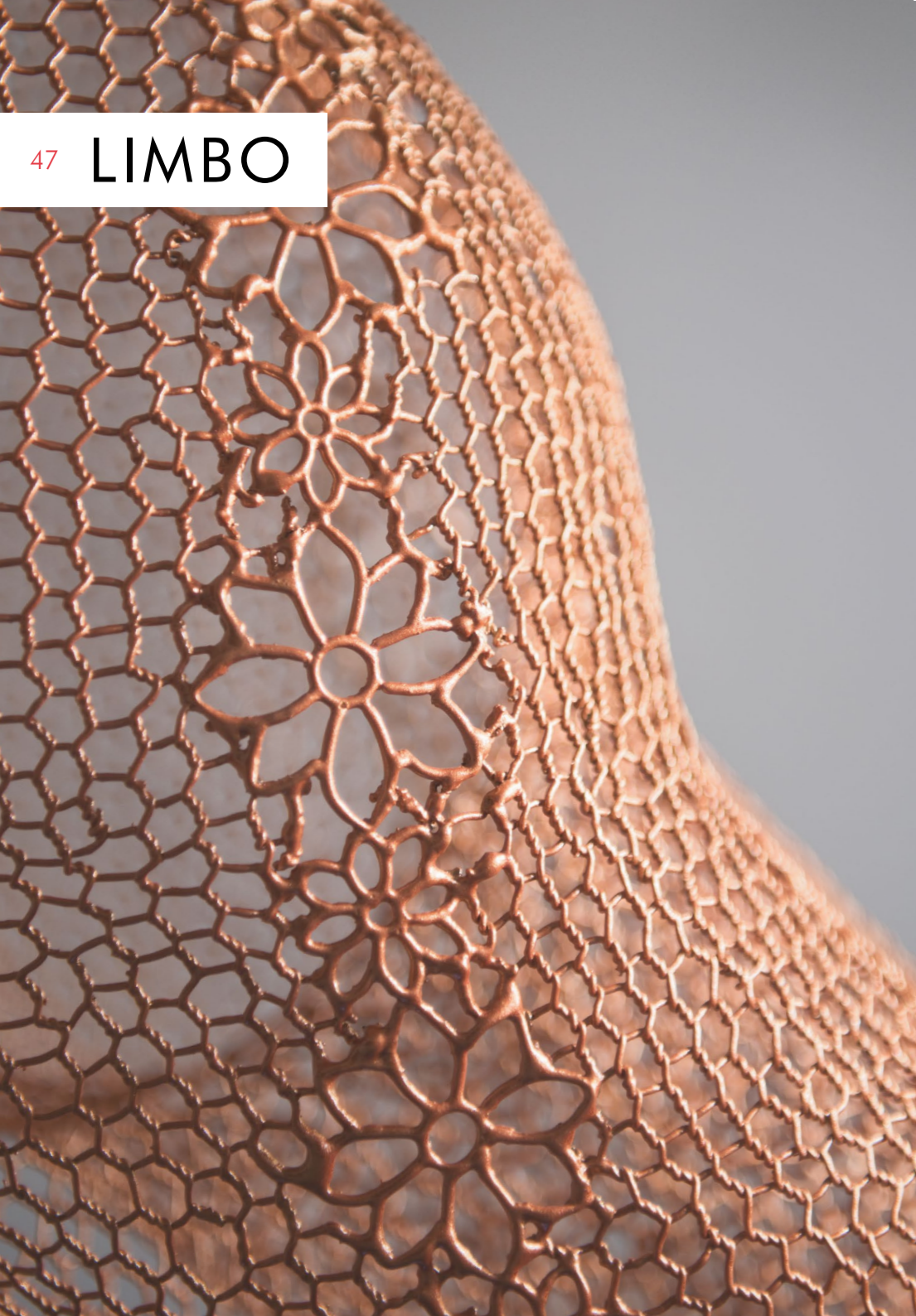

47 LIMBO

ACROBAT

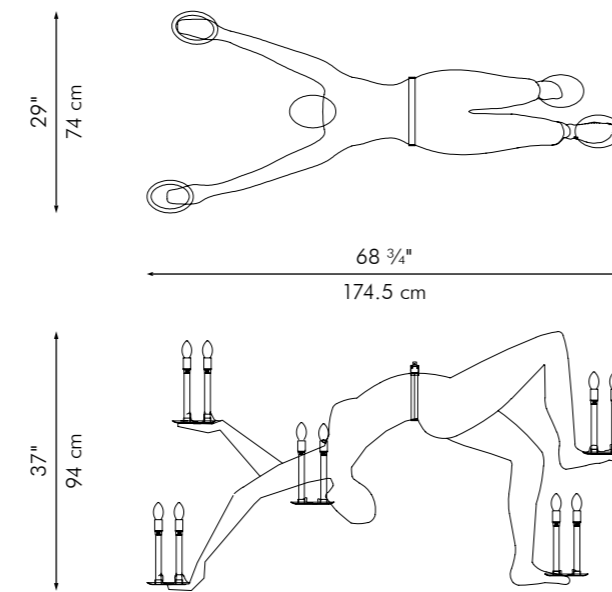

Surface mounted pre-wired lamp
E14
110V - 230V

INDOOR powder-coated steel, brass

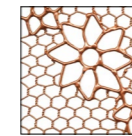

Copper



LIMBO

LIMBO captures a spontaneous moment of an aerialist in mid-flight. Made of gossamer wires handwoven in a lattice pattern, this dramatic design is both an art piece and a functional lamp.

Shown left:
Detail of the LIMBO Acrobat.

Shown right:
The LIMBO Acrobat.



CHANDELIER

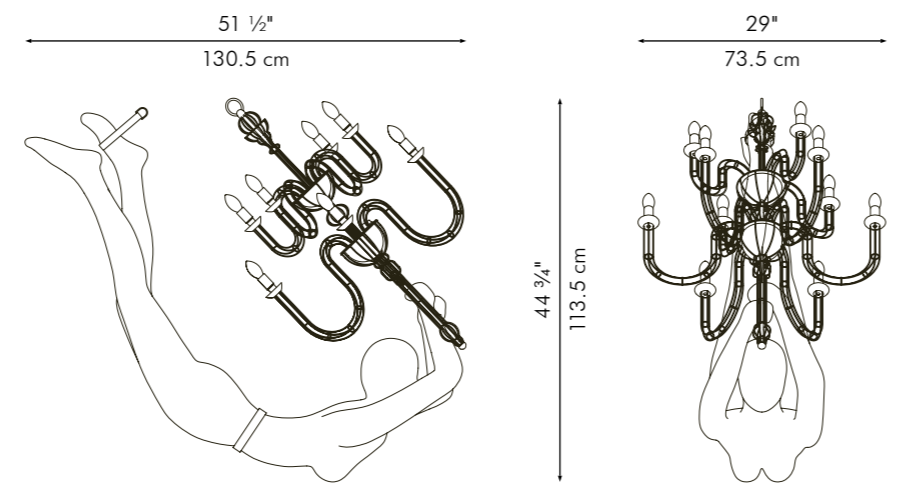

Surface mounted pre-wired lamp
E14
110V - 230V

INDOOR powder-coated steel, brass

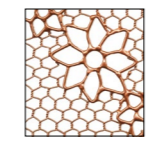

Copper





TRAPEZE

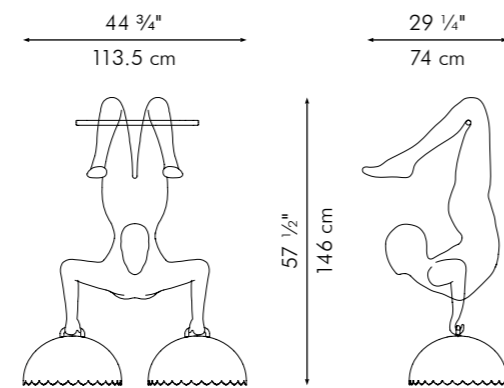

Surface mounted pre-wired lamp
E26 / E27
110V - 230V

LED Chip Version
ANSI
110V / 12-48VDC

IEC/CENELEC
230V / 12-48VDC

INDOOR powder-coated steel, brass

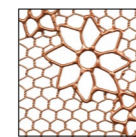

Copper





53 LITTLE PEOPLE

SCREEN

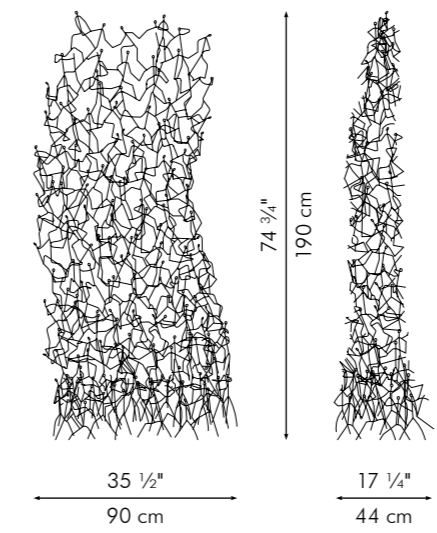

INDOOR Salago fiber, powder-coated steel

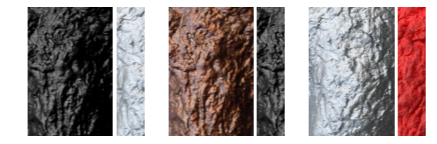

Black with silver accent Bronze with black accent Silver with red accent

*accents are optional



LITTLE PEOPLE

Hundreds of individual figurines embody the playful nature of LITTLE PEOPLE. Salago fiber is applied by hand to add volume and body to a sculptural composition of steel. The result is both dramatic and meaningful, showing what happens when people unite and work together.

Shown left: Detail of the LITTLE PEOPLE screen.

Shown right: LITTLE PEOPLE screen.



ROUND HANGING LAMP

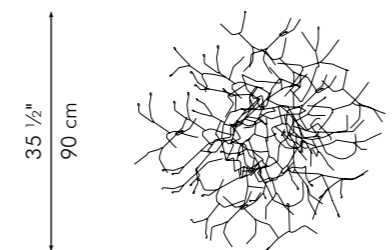

SMALL

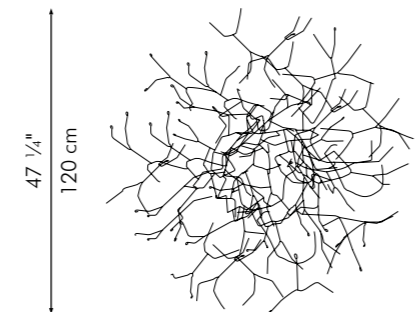

LARGE

RECTANGULAR HANGING LAMP

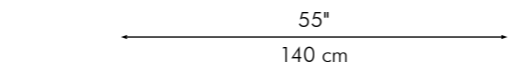
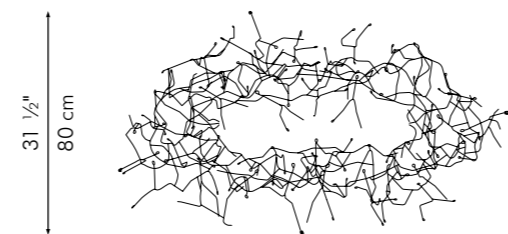

Surface mounted pre-wired lamp
E26 / E27
110V - 230V

INDOOR Salago fiber, powder-coated steel

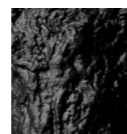

Black

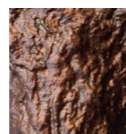

Bronze

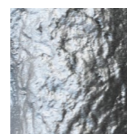

Silver





LITTLE PEOPLE BOOM TOWN

FLOOR LAMP

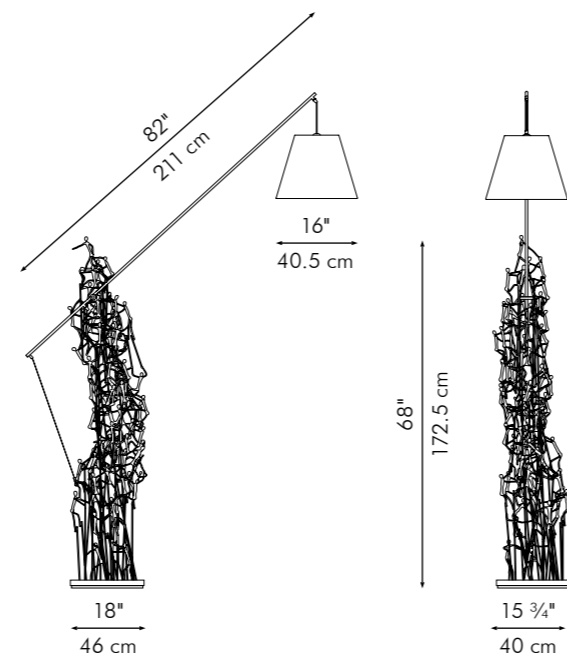

Portable pre-wired lamp
E26 / E27
110V - 230V

INDOOR Salago fiber, powder-coated steel, stainless steel, Mylar



Black Bronze Silver Yellow

*shade available in natural and black

TABLE LAMP

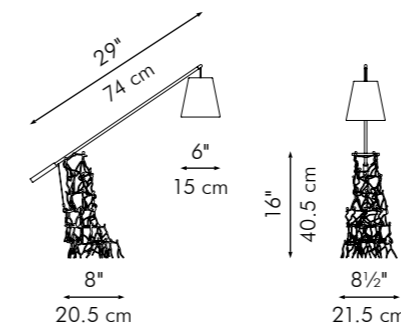

Portable pre-wired lamp
E14 / G9
110V - 230V

INDOOR Salago fiber, powder-coated steel, stainless steel, Mylar



Black Bronze Silver Yellow

*shade available in black only

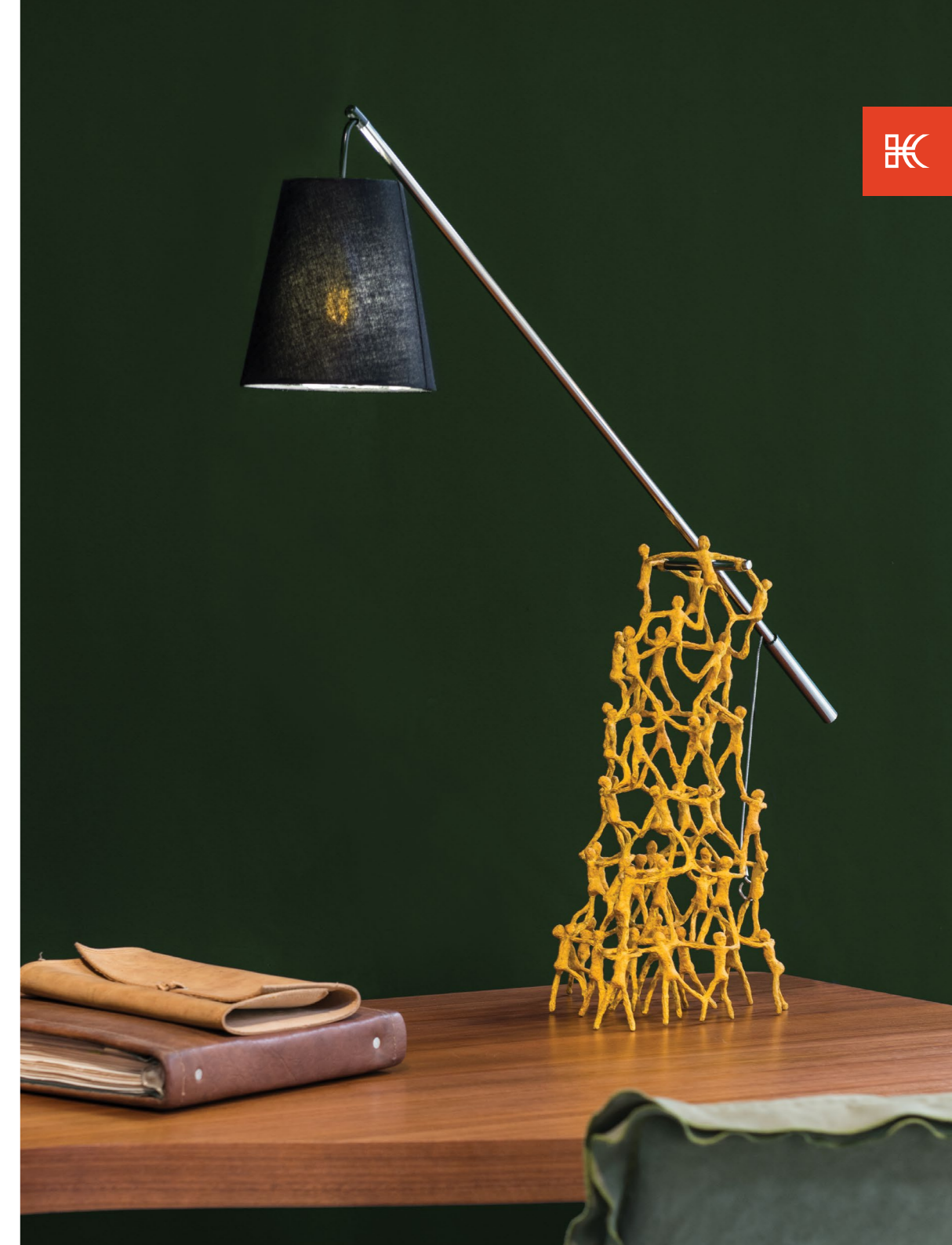



HANGING LAMP

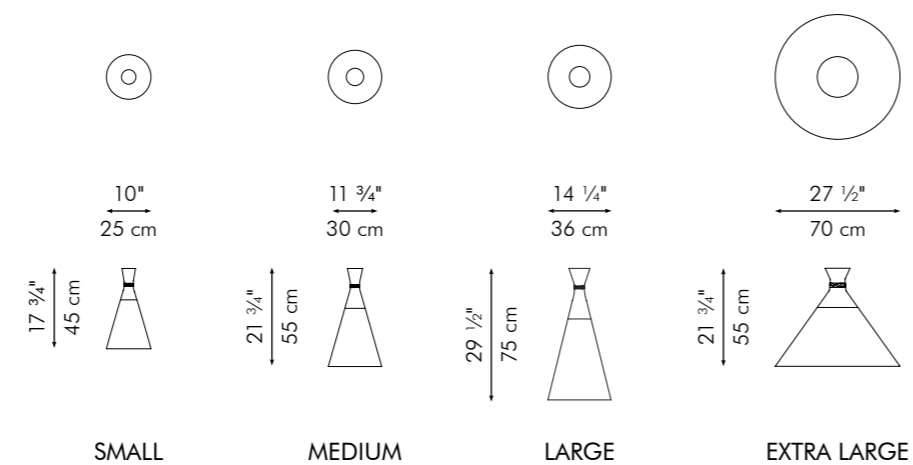

Surface mounted pre-wired lamp
E26 / E27
110V - 230V

INDOOR Salago fiber, Buri (palm leaf spines), powder-coated steel



Cream / Brown

FLOOR LAMP

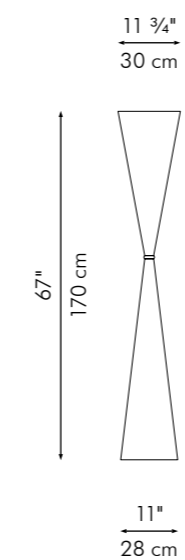

Portable pre-wired lamp
E26 / E27
110V - 230V

INDOOR Salago fiber, Buri (palm leaf spines), powder-coated steel



Cream / Brown



LUAU

LUAU is inspired by the natural torchlights of many tropical islands. Palm leaf spines are tied together and dipped in Salago fiber at one end to capture the beauty of a flickering flame.

Shown left:
LUAU hanging lamps
in various sizes.

Shown right:
LUAU floor lamp with the
Balou easy armchair.

NORI



MIRROR

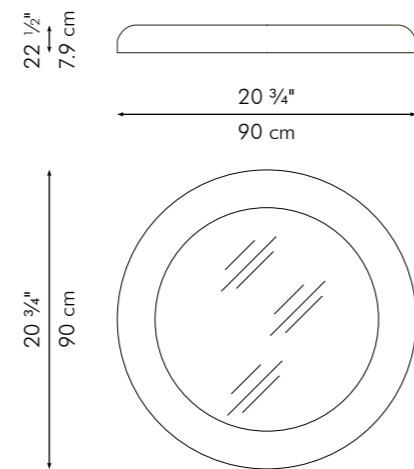

mirror Ø (26 1/2" | 67 cm)
thickness (1/6" | 4 mm)

INDOOR Salago fiber, powder-coated steel

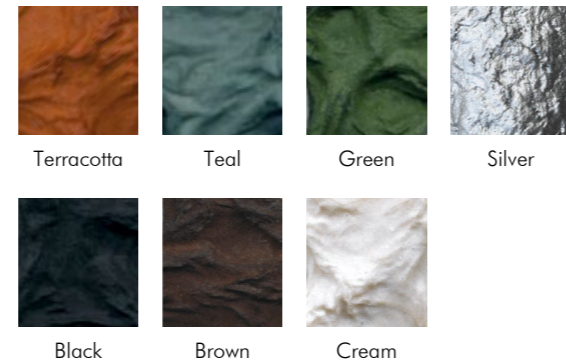

SCREEN

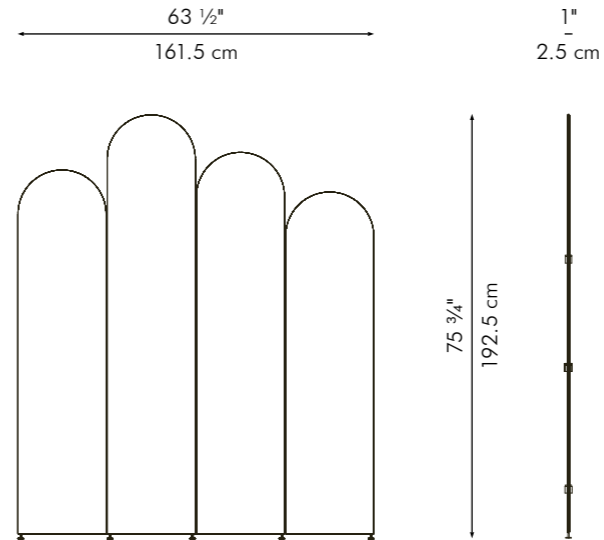

INDOOR Salago fiber, powder-coated steel

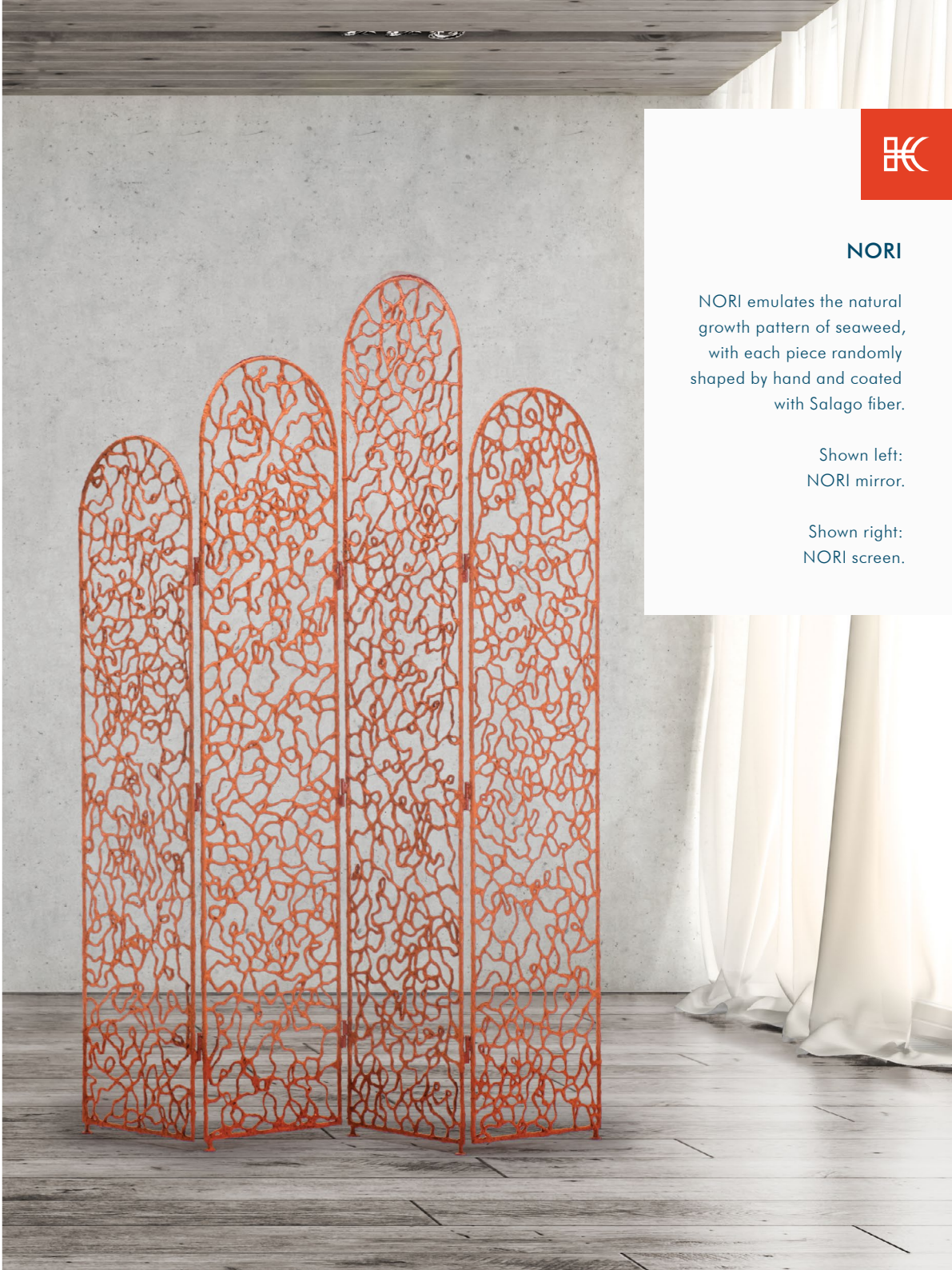
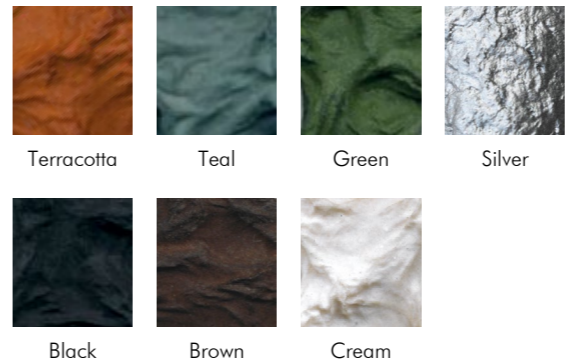

NORI

NORI emulates the natural growth pattern of seaweed, with each piece randomly shaped by hand and coated with Salago fiber.

Shown left:
NORI mirror.

Shown right:
NORI screen.



63 POPPY

HANGING LAMP

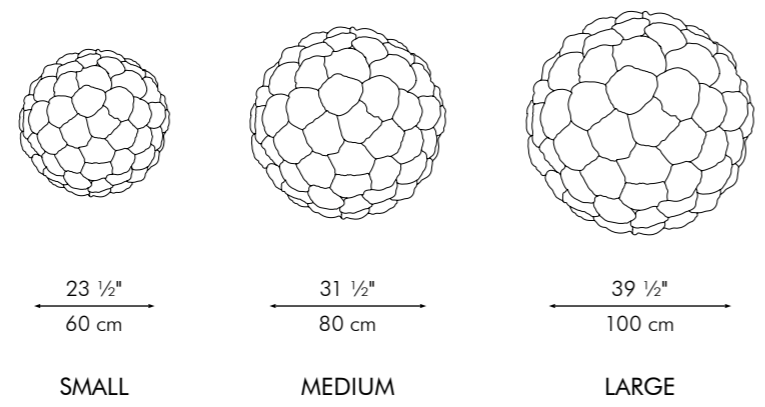

Surface mounted pre-wired lamp
E26 / E27
110V - 230V

INDOOR handmade paper, Tyvek, powder-coated steel



Cream



POPPY

POPPY is an assemblage of handmade paper blossoms reminiscent of flowers freshly plucked from a garden. The folded petals are laminated with Tyvek and attached to each other over a wire frame, giving a warm glow to every room.

by Christy Manguerra

Shown left:
Detail of the POPPY
hanging lamp.

Shown right:
POPPY hanging lamp
in medium.



65 SAFARI

PLANTERS

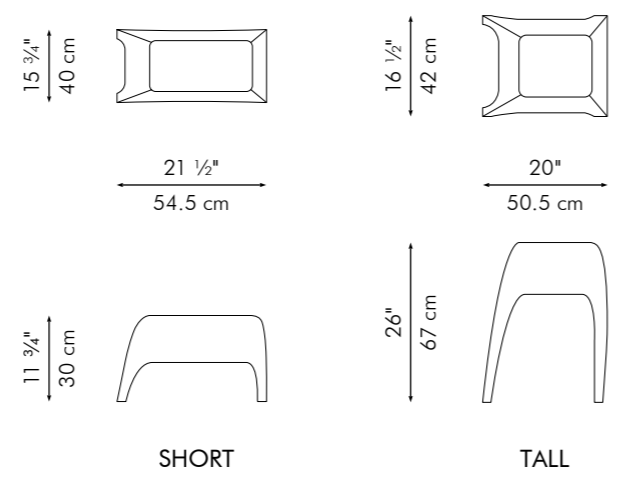

OUTDOOR cast stone

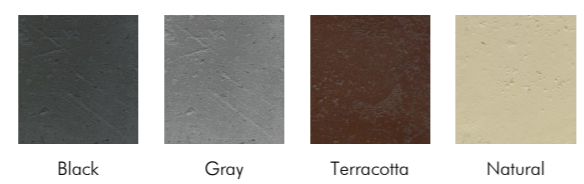

SAFARI

Bring nature into any space with these four-legged creations. Made of cast stone, the SAFARI planters come in a tall and short version.

Shown left:
Short SAFARI planter in gray.

Shown right:
Short and tall SAFARI planters in terracotta.

67 SHIREEN

TABLE LAMP

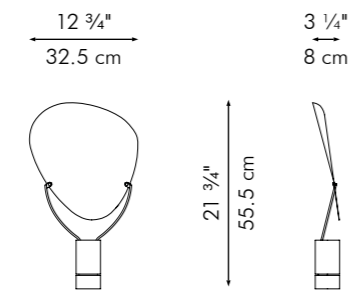

MEDIUM

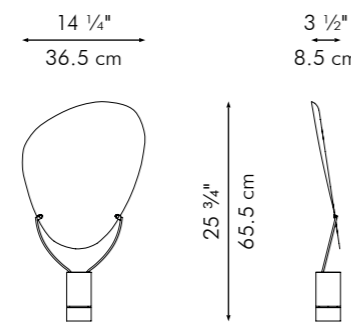

LARGE

Portable pre-wired lamp
GU10
110V - 230V

INDOOR copper, powder-coated steel

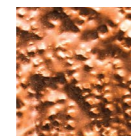

Copper

HANGING LAMP

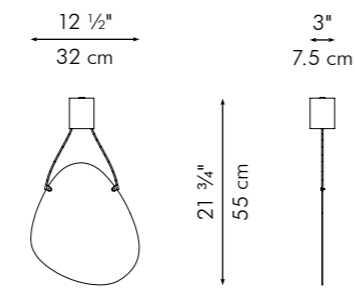

MEDIUM

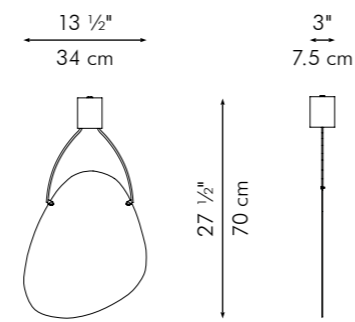

LARGE

Surface mounted pre-wired lamp
GU10
110V - 230V



SHIREEN

SHIREEN is made of hand-hammered copper sheets that glow with a warm and beautiful reflection when lit. The soft light is both mystical and romantic, adding drama to any room.

Shown left:
SHIREEN table lamps
in medium and large.

Shown right:
SHIREEN hanging lamps in
medium and large.
SHIREEN table lamp in large.

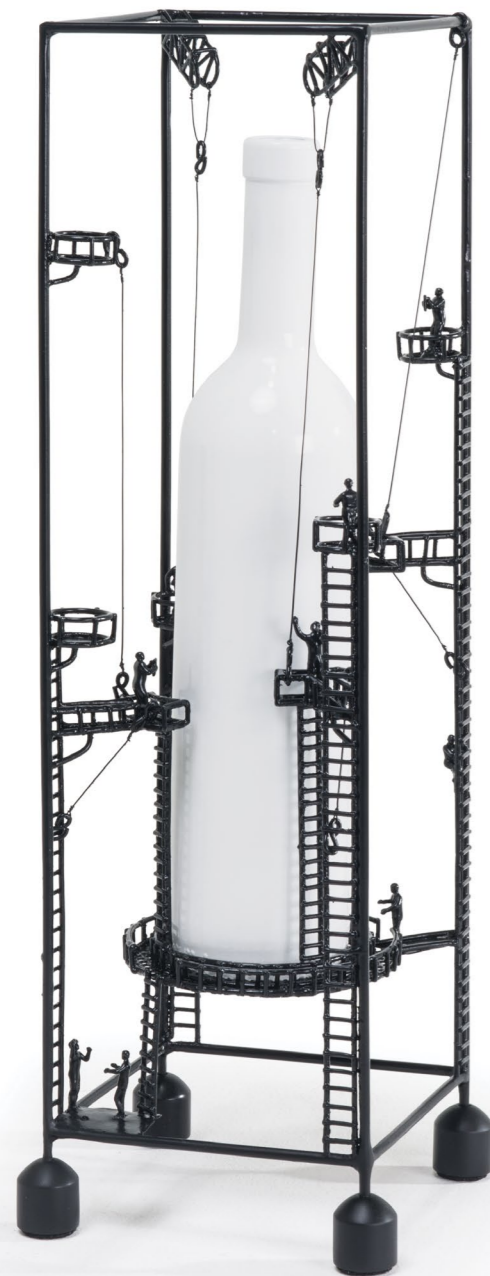

WINE BOTTLE HOLDER

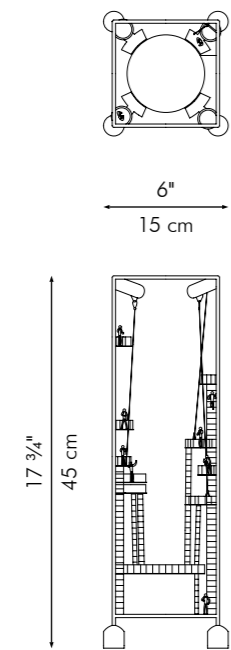

INDOOR brass



Black



Silver

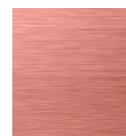

Rose Gold



SHUTTLE

Make special occasions more memorable with the SHUTTLE wine bottle holder. Made of cast brass and metal, the crew perched on the structure is seen preparing the vessel for a long and enjoyable night ahead.

Shown Left:
The SHUTTLE wine bottle holder in black.

Shown right:
The SHUTTLE wine bottle holder in rose gold and silver.

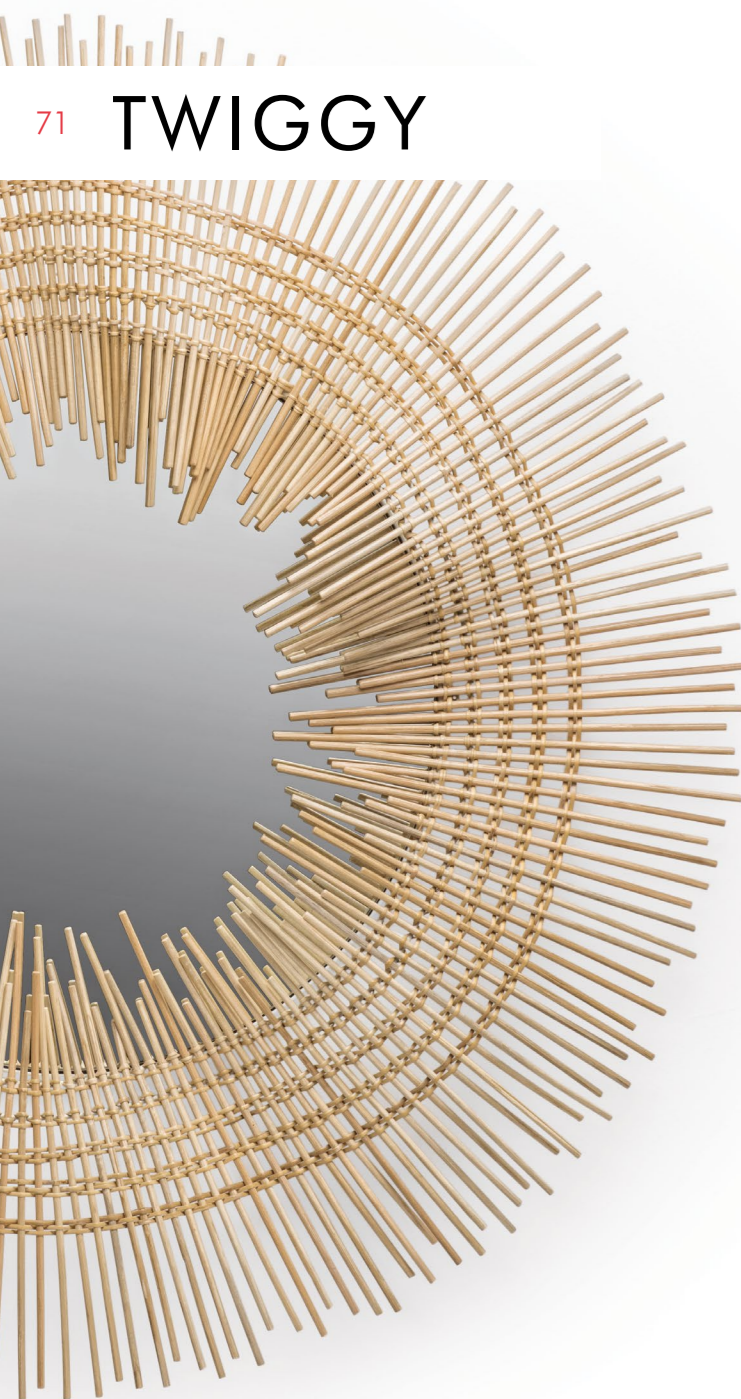

71 TWIGGY

MIRROR

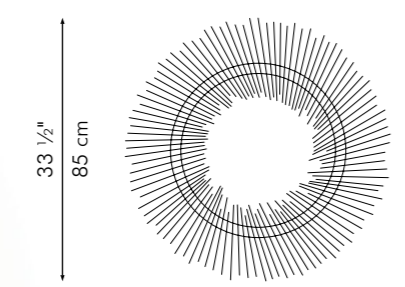
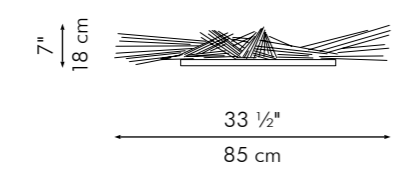

SMALL

mirror Ø (19 3/4" | 50 cm)
thickness (1/6" | 4 mm)

INDOOR rattan, powder-coated steel



Natural

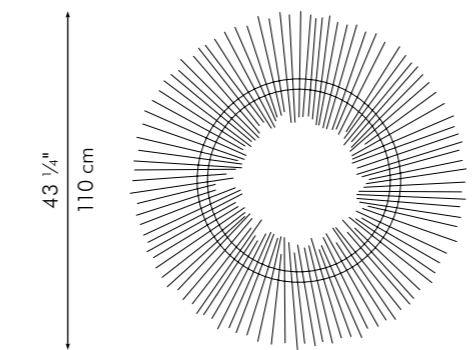
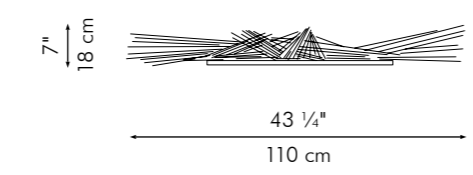

LARGE

mirror Ø (23 1/2" | 60 cm)
thickness (1/6" | 4 mm)



TWIGGY

Like the rays of the sun, the TWIGGY mirror is made of fine lines beaming from its center. Rattan spokes are woven over a steel frame, creating a radial pattern with gentle slopes.

Shown left:
Detail of the TWIGGY mirror.

Shown right:
The TWIGGY mirror in large.

73 VILLAGE



HANGING LAMP

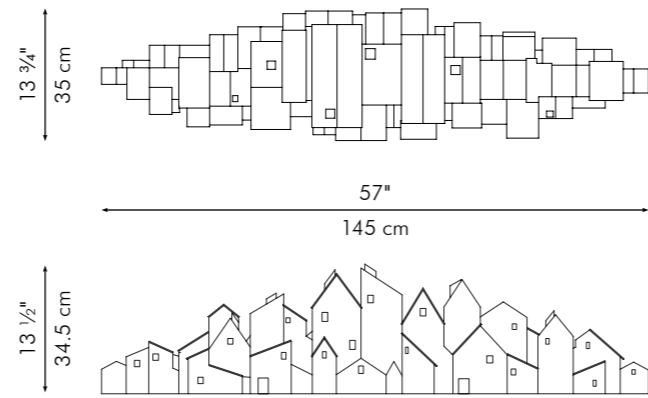

Surface mounted pre-wired lamp
E26 / E27
110V - 230V

INDOOR fiber-reinforced polymer, wood



Whitewash



VILLAGE

A scaled interpretation of old-world European townscapes, VILLAGE is made from fiber-reinforced polymer and wood, creating a warm, ethereal radiance in any living space.

Shown left:
Detail of the VILLAGE hanging lamp.

Shown right:
The VILLAGE hanging lamp with black and lime green Yoda side chairs.

75 WHISK



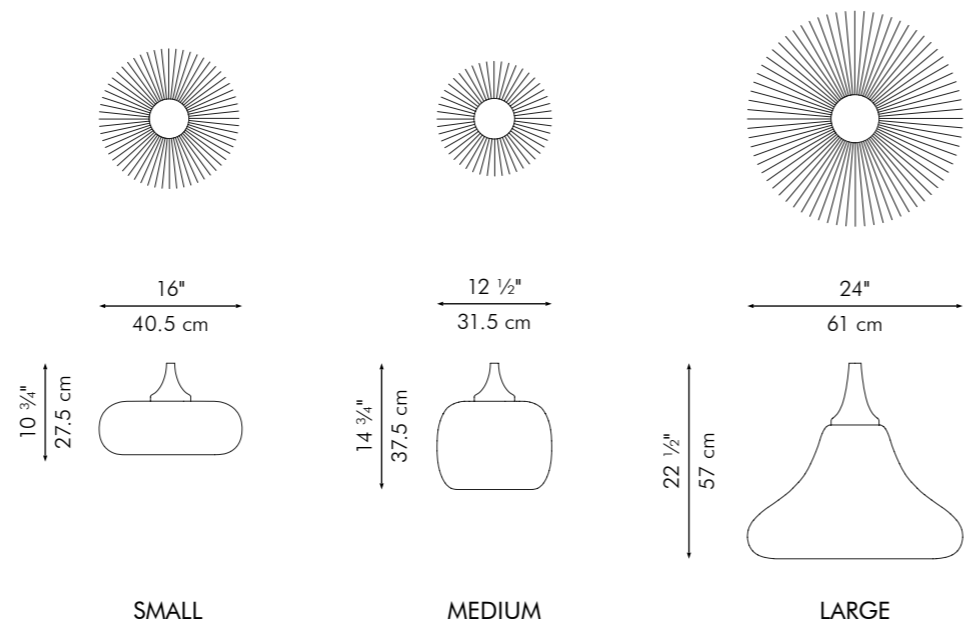

HANGING LAMP

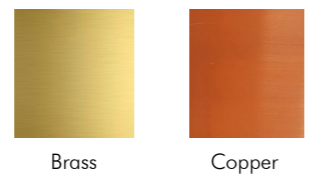

Surface mounted pre-wired lamp
GU10
110V - 230V

INDOOR powder-coated steel, fiber-reinforced polymer

WHISK

The WHISK hanging lamp is an elegant play of lines and reflections made by the curved forms of the wire frames. Made of painted steel and fiber-reinforced polymer.

by Stanley Ruiz

Shown left:
WHISK hanging lamps
in small and medium.

Shown right:
WHISK hanging lamps
in large.

77 WIGGLE



SCULPTURE

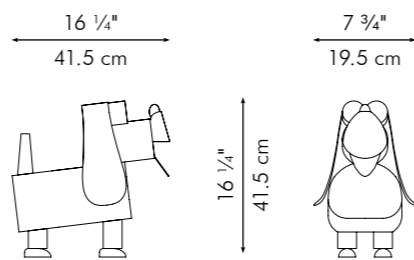

INDOOR powder-coated steel, microfiber, leather

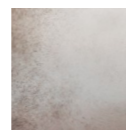

Silver



WIGGLE

WIGGLE captures the joyful moment of a dog meeting its owner. Inspired by vintage mechanical toys, the metal surfaces are formed and welded by hand, then finished in a warm, faded patina. With springs as legs, WIGGLE bounces up and down with a slight pat on its back.

Shown left:
Different angles
of WIGGLE.

Shown right:
WIGGLE with the
Lolah collection.

DESIGNERS



KENNETH COBONPUE

Philippines

Kenneth Cobonpue is a multi-awarded industrial designer and manufacturer from Cebu, Philippines. After finishing Industrial Design at the Pratt Institute in New York, he established his namesake brand KENNETHCOBONPUE upon returning home to Cebu in 1996. With his masterful way of integrating nature, traditional craft, and innovative technologies, he reveals new work each year in design shows from Milan to New York. While he continues to design, he is proactive in his advocacy of mentoring young designers and promoting South East Asian design to the world.



CHRISTY MANGUERRA

Philippines

With a strong grasp on design theory and practice, Christy has proven successful in her academic pursuits as a graduate with a Fine Arts degree from the University of the Philippines-Cebu and a Masters degree in Design Management from the University of New South Wales in Australia. Equipped with creative vision and experience, she continues to share her knowledge and expertise as a teacher of Industrial Design at the University of the Philippines-Cebu, and leads the product development team at KENNETHCOBONPUE.



DANNY FANG

Netherlands / Hong Kong

After graduating from the Academy of Eindhoven in Holland, Dutchman Danny Fang worked alongside Marcel Wanders and became a designer for Moooi. He then moved to Hong Kong where he set up Fang Studio Ltd. With the belief that “design needs to contribute to the world in an inspiring, comfortable, and attractive way,” Danny has a number of recognitions and awards to his name, including Perspective Magazine’s title as one of the “40 under 40” talented and young individuals who lead Asia’s design industry, as well as the prestigious Design for Asia Award.



STANLEY RUIZ

Philippines

Stanley Ruiz is an industrial designer currently based in Philippines / New York City. Graduating from the University of the Philippines-Diliman. With an affinity for combining traditional craft techniques with contemporary design aesthetics, he produces cleverly reinterpreted objects that display both foreign and familiar qualities. Often described as “transcultural” and “poetic,” Stanley has received numerous recognitions, including being hailed as one of the Avant Guardians of 2010 by the New York-based Surface Magazine; the Bronze Award at the A’Design Awards in Italy in 2013; an Outstanding Asia Talents award at the Bangkok International Gift Fair in 2014; and one of the six Rising Asian Talents in Maison&Objet Asia in Singapore in 2016.

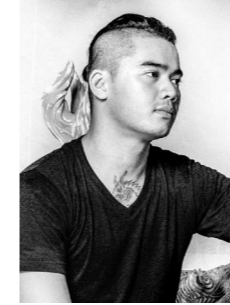

LEEROY NEW

Philippines

Young, unpredictable, and exciting, Leeroy New lives up to his surname as an artist-designer whose practice overlaps and intersects with film, theater, product design, and fashion with his works having received numerous citations. The Manila-based and multi-faceted designer from General Santos is a graduate of the University of the Philippines College of Fine Arts, and the Philippine High School for the Arts, where he majored in Visual Arts. He is best known to have collaborated with Kermit Tesoro in designing the famous muscle dress that Lady Gaga wore in her music video, "Marry the Night." He also had works exhibited during the Singapore Biennale in 2008 and Fukuoka Asian Art Triennale in 2009.



LUISA ROBINSON

Philippines

Hailing from Manila where she studied Interior Design and Industrial Design, Luisa is an advocate of modern and clean design, integrating natural indigenous materials with modern technology and applications. A recipient of numerous Katha and Mugna awards for best product design and material innovation and a merit award for furniture design in Singapore, Luisa was honored as one of the Top Ten Design Iconoclasts by The Philippine School of Interior Design.



HAE YOUNG YOON

South Korea

Hae Young Yoon, the South Korean native from Seoul, studied Industrial Design at the University of the Philippines-Cebu under Kenneth Cobonpue and Christy Manguerra. The Cloud hanging lamp, which started as her student project at the age of 19, has become an increasingly popular accessory that reflects the vibrant imagination that comes with youth.



CREDITS

PHOTOGRAPHY

Paolo Konst
Raymond Ang
Christy Manguerra
Sigrid Ponce



www. **KENNETH**COBONPUE.com