

REF. 2.118

MH2206C Mesa de Rincón

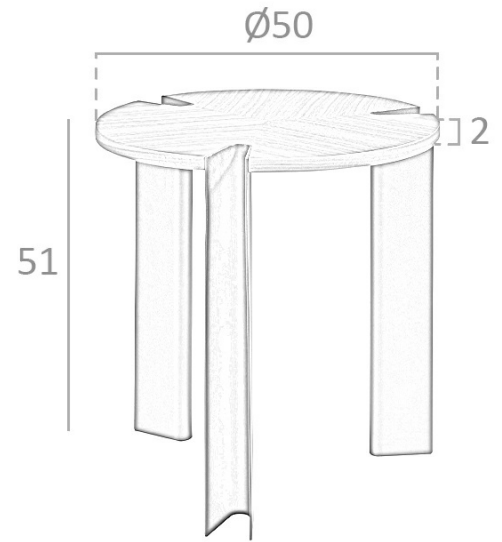

MEDIDAS

Medidas: Ø50 x 51 cm.

Peso: 13 Kg.

Forma: Redonda

EMBALAJE

55 x 55 x 20 cm. / 15 Kg.

VOLUMEN

0,07 m³

PRODUCTO

Chapa Nogal

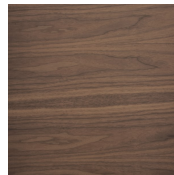

PATAS

Material Patas: Acero color Negro

